

# Table Saw

## Model 4065

Owner's Manual

For Models Manufactured Since 06/2023



Oliver Machinery  
1-800-559-5065  
921 Thomas Ave SW,  
Renton, WA 98057

info@olivermachinery.net  
WWW.OLIVERMACHINERY.NET

Stock Number: 4065.002  
4065.003  
Manual Version: 1.0.0





**READ AND UNDERSTAND ALL INSTRUCTIONS IN THIS MANUAL BEFORE ATTEMPTING TO ASSEMBLE OR OPERATE THE MACHINE.**

**FOLLOW THE INSTRUCTIONS AND THINK SAFETY!**

**THE OWNER OF THIS MACHINE IS SOLELY RESPONSIBLE FOR THE SAFETY OF ANYONE USING THIS MACHINE. SUCH RESPONSIBILITY INCLUDES BUT NOT LIMITED TO THE FOLLOWING:**

- **PROPER ASSEMBLY, OPERATION, INSPECTION, MAINTENANCE, AND RELOCATION OF THE MACHINE.**
- **PROPER TRAINING FOR THE OPERATORS AND ENSURING THIS MANUAL IS AVAILABLE AT ALL TIMES.**
- **USAGE AUTHORIZATION.**
- **USAGE OF SAFETY AND PROTECTION DEVICES.**

**OLIVER MACHINERY DISCLAIMS ANY LIABILITY FOR MACHINES THAT HAVE BEEN ALTERED OR ABUSED. OLIVER MACHINERY RESERVES THE RIGHT TO EFFECT AT ANY TIME, WITHOUT PRIOR NOTICE, THOSE ALTERATIONS TO PARTS, FITTINGS, AND ACCESSORY EQUIPMENT THAT THEY MAY DEEM NECESSARY FOR ANY REASON WHATSOEVER.**

**\*\* SAVE THIS MANUAL FOR FUTURE REFERENCE. \*\***

## **PROP 65 NOTICE**

**WARNING:** Drilling, sawing, sanding, or machining wood products can expose you to wood dust and other chemicals known to the State of California to cause cancer, birth defects, or other reproductive harm.

Some examples of these chemicals are:

- Lead from lead-based paints.
- Crystalline silica from bricks, cement, and other masonry products.
- Arsenic and chromium from chemically treated lumber.

Avoid inhaling wood dust and other harmful chemicals. Use a dust mask and other safety devices for personal protection.

For more information, go to <http://www.P65Warnings.ca.gov/wood>

## Table of Contents

<b>Introduction</b> .....	<b>5</b>	After Using the Table Saw.....	47
<b>Specifications</b> .....	<b>6</b>	<b>Calibrations and Adjustments</b> .....	<b>48</b>
<b>Identification</b> .....	<b>10</b>	Blade to Miter Slot Alignment .....	48
<b>Safety</b> .....	<b>12</b>	Fence Lock Tightness Adjustment.....	49
<b>Electricals</b> .....	<b>14</b>	Fence to Miter Slot Alignment.....	49
Minimum Circuit Size Required for Model 4065 Table Saw .....	14	Fence Squareness Adjustment.....	50
Grounding.....	14	Fence Height Adjustment .....	50
Electrical Wiring .....	15	Fence Scale Adjustment.....	51
230V/460V Conversion.....	16	Miter Gauge Angle Indicator Adjustment....	51
<b>Setup</b> .....	<b>17</b>	Blade Tilt Angle Pointer Adjustment.....	52
Shop Preparation.....	17	Blade Angle Positive Stops Adjustments.....	52
Receiving .....	18	Spreader/Riving Knife Mounting Bracket Alignment Adjustment.....	54
Unboxing & Inventory .....	19	<b>Maintenance</b> .....	<b>55</b>
Lifting Table Saw Main Unit from Pallet.....	21	Dust Accumulation Removal.....	55
Cleaning.....	21	Trunnion Components Cleaning and Lubrication .....	56
Leveling Main Unit.....	22	Belt Tension Adjustment.....	57
Essential Mechanical Inspections Before Assembly .....	22	Belt Replacement.....	58
Electrical Connection and Tests .....	26	Table Insert Setup .....	59
<b>Assembly</b> .....	<b>27</b>	<b>Troubleshooting</b> .....	<b>61</b>
Rails and Extension Table Installation.....	27	<b>Wiring Diagrams</b> .....	<b>65</b>
Fence Setup.....	30	For Stock # 4065.002 (230V/460V, 3Ph) .....	65
Dust Collection .....	32	For Stock # 4065.003 (230V/460V, 3Ph) .....	66
Moving and Leveling the Saw.....	32	<b>Parts List</b> .....	<b>67</b>
<b>Accessories</b> .....	<b>33</b>	Table and Blade Guard.....	67
<b>Operation</b> .....	<b>34</b>	Cabinet .....	68
Safety Guidelines for Preparing for a Cut.....	34	Motor and Blade Lift Assembly.....	69
Safety Guidelines for Using the Table Saw...38		Trunnion Assembly .....	70
Changing Saw Blade .....	39	Rails .....	71
Swapping Riving Knife / Blade Guard .....	40	Extension Table .....	72
Using the Digital Readout.....	40	Rip Fence Assembly.....	73
Making a Rip Cut .....	41	Miter Gauge .....	74
Making a Cross Cut.....	43	<b>Maintenance Record</b> .....	<b>84</b>
Making a Miter Cut.....	45	<b>Notes</b> .....	<b>85</b>
Making a Bevel Cut.....	45	<b>Warranty and Service</b> .....	<b>86</b>
Cutting with Dado Set .....	46		

# Introduction

Thank you for choosing Oliver! This manual contains important information on safely setting up, operating, and maintaining this machine. Please take the time to read through this manual and make sure you understand all instructions.

While this manual may provide tips on optimizing the result of your workpiece, the manual is not intended as a substitute for formal woodworking training. If you need to know how to safely complete a woodworking task, please consult knowledgeable and qualified sources before proceeding further.

We made every effort to keep this manual up-to-date. Instructions, specifications, drawings, and photographs in this manual should match the machine delivered. If you find any differences or anything that seems confusing in this manual, please check our website for an updated version:

**[WWW.OLIVERMACHINERY.NET/MANUALS](http://WWW.OLIVERMACHINERY.NET/MANUALS)**

Alternatively, you can contact our technical support for help:

**1-800-559-5065**

Before calling, please note down the manufacture date and the serial number of the machine. You can find the information on a nameplate which is on the back of the table saw's cabinet. This information is needed to provide proper technical support and to determine if an updated manual is available for your machine.

Please let us know how well this manual serves you. If you have any suggestions, please call the number above or email us at:

**[info@olivermachinery.net](mailto:info@olivermachinery.net)**

We love to hear from our customers and make improvements.

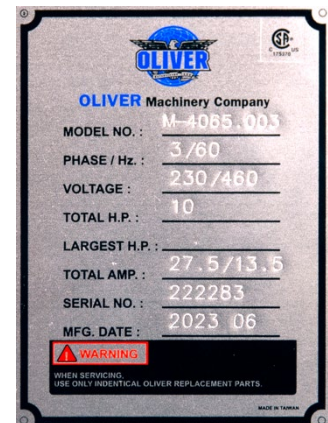

# Specifications

## Quick View

Model	4065 Table Saw	
Stock Number	4065.002	4065.003
Rip Capacity	52"	
Blade Diameter	14"	16"
Motor	TEFC 7.5HP	TEFC 10HP
Power Requirement	230/460V, 3Ph, 60Hz	
Dimensions	82"(L) x 48"(D) x 44"(H)	
Fully Assembled Weight	814 lbs.	
Warranty	1 Year (Motor and electronics) 2 Years (All other parts)	

## Product Dimensions

Fully Assembled Dimensions	82"(L) x 48"(D) x 44"(H)
Footprint	74" (L) x 39"(D)
Fully Assembled Weight	814 lbs.

## Shipment Info

<b>Table Saw Main Unit</b>	
Packaging	Wood Crate with Pallet Base
Dimensions	43-1/2"(L) x 42-1/2"(D) x 44-3/4"(H)
Weight	784 lbs.
<b>Rails</b>	
Packaging	Wood Crate
Dimensions	87-1/2"(L) x 7-1/2"(D) x 9"(H)
Weight	96lbs
<b>Right Extension Table</b>	
Packaging	Wood Crate
Dimensions	48-1/2"(L) x 43"(D)x 9"(H)
Weight	152lbs.
<b>Fence</b>	
Packaging	Wood Crate
Dimensions	52-3/4"(L) x 21"(D) x 11"(H)
Weight	60lbs.
Approx. Setup Time	120 Minutes
Must Ship Upright	YES
Stackable	NO

### Electricals

Stock Number	4065.002	4065.003
Power Requirement	230/460V, 3Ph, 60Hz	230/460V, 3Ph, 60Hz
Prewired Voltage	230V	
Full Load Current Rating	19.5A @ 230V	27.5A @ 230V
	9.5A @ 460V	13.5A @ 460V
Recommended circuit size	25A @ 230V	35A @ 230V
	15A @ 460V	20A @ 460V
Power Switch Type	Lockable Magnetic Button Switch	
Connection Type	Cord and plug are not included. Electrical hookup by licensed electrician required.	

### Saw Details

Stock Number	4065.002	4065.003
Table Saw Type	Cabinet	
Arbor Size	1"	
Max. Blade Diameter	14"	16"
Max. Dado Blade Diameter	12"	
Max. Dado Blade Width	11/16"	
Max. Blade Tilt	45° to the left	
Max. Depth of Cut at 90°	5-1/8"	6-1/8"
Max. Depth of Cut at 45°	3-5/8"	4-3/8"
Rail Length /	52"	
Max. Rip Right of Blade		
Max. Rip Left of Blade	10"	
Riving Knife/Spreader Thickness	1/8"	
Required Blade Kerf Thickness	> 9/64"	
Arbor Speed	3800 RPM	
Max. Allowable Arbor Runout	0.001"	

### Fence

Fence Dimensions	43-1/4"(L) x 4-5/8"(W) x 2-1/2"(H)
Fence Type	Camlock T-Shape Fence
Fence Face Material	HDPE
Fence Body Material	Steel

### Table

Stock Number	4065.002	4065.003
Material	Precision Ground Cast Iron	
Main Table Dimensions	35-13/16"(L) x 39"(D)	
Extension Table Dimensions	42-1/2"(L) x 39"(D)	
Overall Table Size	78-5/16" (L) x 39"(D)	
Table Height from Floor	34-3/8"	
Main Table Flatness Tolerance	0.01"	
Overall Table Flatness Tolerance	0.025"	
Distance from Front Edge to Blade	14-7/8" (at max blade height)	14" (at max blade height)
Distance from Rear Edge to Blade	10-1/2" (at max blade height)	9-1/4" (at max blade height)
Miter Slot Type	T-Slot (Standard Size)	
Miter Slot Size (W x H)	3/4" x 3/8"	
Blade Alignment /w Miter Slot	<= 0.0079"	
Table Insert Provided	Zero clearance insert	

### Included Blade Information

Stock Number	4065.002	4065.003
Type	General-purpose 72T blade	General-purpose 80T blade
Size	14"	16"
Kerf	9/64" (3.5mm)	
Blade Plate Thickness	3/32" (2.5mm)	

### Miter Gauge

Angle Range	-60° to 60°, with positive stops at -30°, 45°, 0°, 30°, 45°	
Miter Bar Length	19-1/8"	
Fence Dimensions	12-3/4" (L) x 2-13/16" (H)	
Fence Type	Extruded Aluminum with T-Slot for 1/4" Bolts	

### Motor

Stock Number	4065.002	4065.003
Motor Type	TEFC	
Horsepower	7.5HP	10HP
Power Requirement	230V / 460V, 3Ph, 60Hz	
Full Load Current Rating	19.5A @ 230V	27.5A @ 230V
	9.5A @ 460V	13.5A @ 460V
Efficiency	82.2%	82.6%
Power Factor	89.8%	85.3%
Speed	3450 RPM	
Power Transfer Mechanism	Poly V-Belt	
Bearing type	Permanently Sealed Ball Bearing	



### *Cabinet*

Type	Steel cabinet with built-in accessories hanger.
Mobility	Built-in swivel casters with leveling feet.
Digital Readout	LCD display for blade angle and height.

### *Safety*

Blade Guard	Polycarbonate blade guard with anti-kickback paws.
Riving Knife	Steel riving knife.
Number of Dust Ports	1
Dust Port Size	4"
Minimum CFM Required	500 CFM
Sound Rating	94 dB at 2' with the blade lowered below the table.

### *Others*

Serial Number Location	On the back of the cabinet.
Certification	CSA 175370
Country of Origin	Taiwan

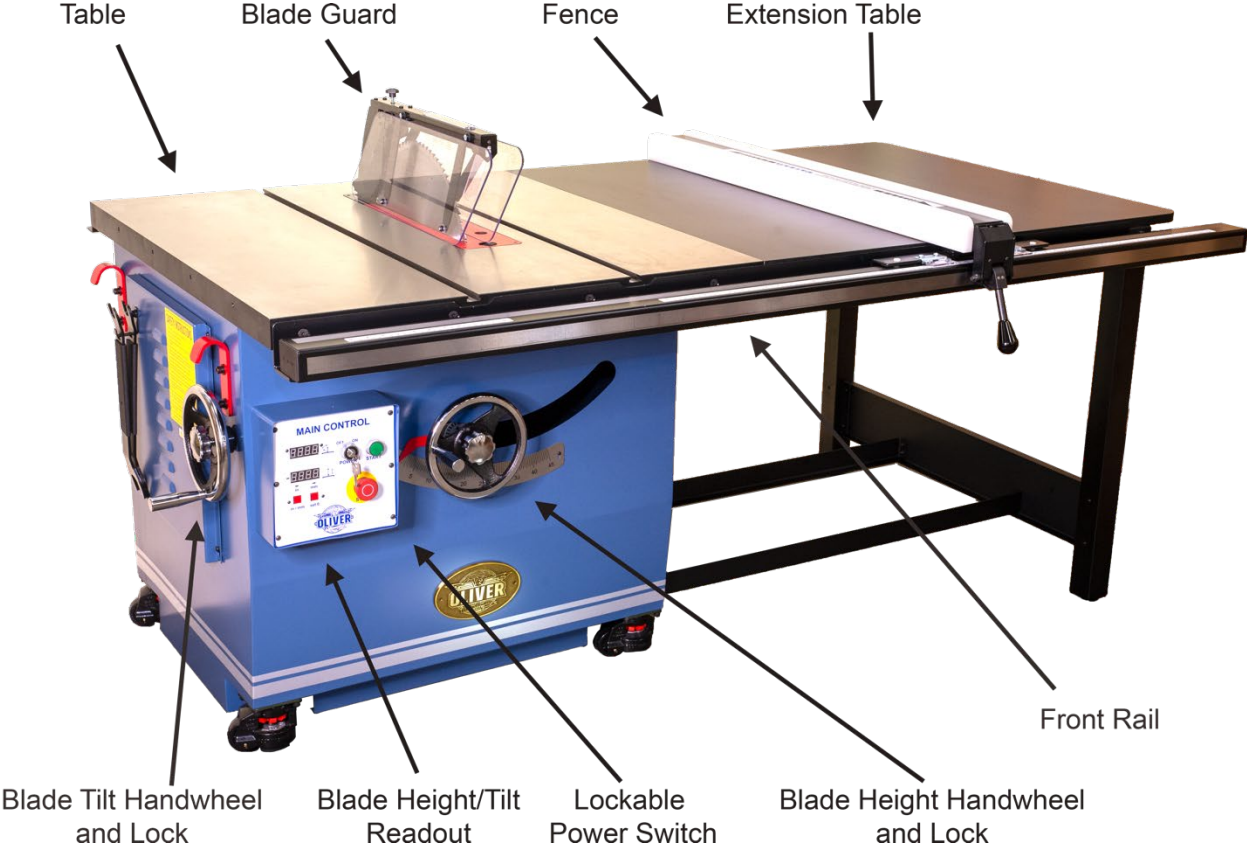

# Identification

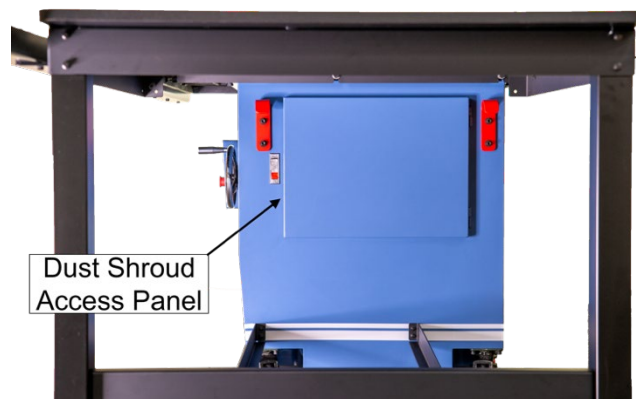
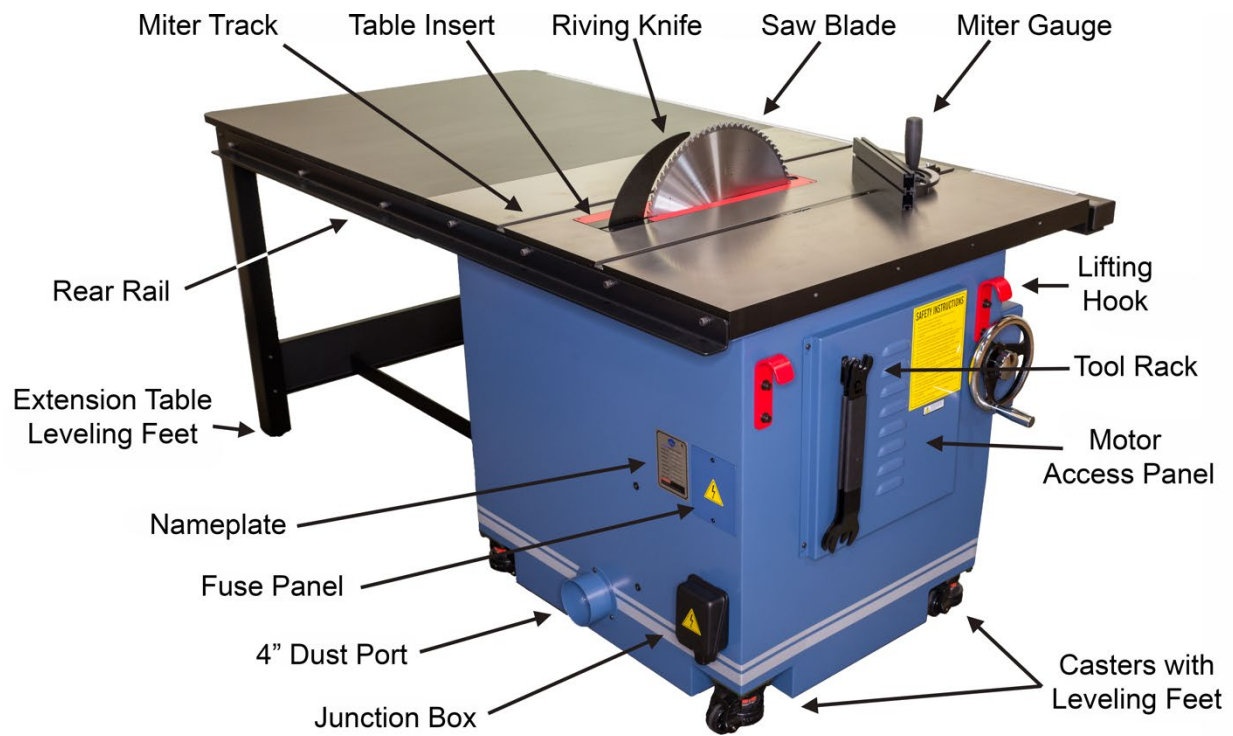



# Safety

Oliver Machinery has made every attempt to provide a safe, reliable, easy-to-use piece of machinery. Safety, however, is ultimately depending on the individual machine operator. **Please familiarize yourself with the following safety labels used throughout this manual.**

 <b>DANGER</b>	This indicates an imminently hazardous situation which, if not avoided, <b>WILL</b> cause death or serious injury.
 <b>WARNING</b>	This means if the warning is not taken seriously, it <b>CAN</b> cause death or serious injury.
 <b>CAUTION</b>	This means if the precaution is not taken, it <b>MAY</b> cause minor or moderate injury.
<b>IMPORTANT</b>	This is a tip for properly operating the machine to avoid machine damage.



**BEFORE OPERATING THIS TABLE SAW, READ AND UNDERSTAND THE SAFETY GUIDELINES IN THIS MANUAL AND EXERCISE ALL SAFETY PRECAUTIONS. WHEN IN DOUBT, PLEASE CONSULT ACCREDITED TRAINING RESOURCES OR CONTACT OLIVER MACHINERY FOR HELP. FAILURE TO FOLLOW THE SAFETY GUIDELINES CAN RESULT IN SERIOUS INJURIES OR DEATH.**

## General Safety Guidelines

1. **FAMILIARIZE** yourself with all safety instructions found in this manual. Know the limitations and hazards associated with this machine. Do not operate/service this machine until you are properly trained.
2. **ELECTRICAL GROUNDING**, when done properly, reduces the risk of electrocution, shocks, and fire. Ensure the machine frame is electrically grounded and a ground lead is included in the incoming electrical service. In cases where a cord and a plug are used, ensure the grounding plug connects to a suitable ground. Follow the grounding procedure indicated in the electrical code of your area.
3. **DISCONNECT** the machine from power before performing any service, maintenance, adjustments, or changing cutters. A machine under repair should be RED TAGGED to show it should not be used until the maintenance is complete.
4. **GUARDS**: Keep machine guards in place for all applicable operations. If any guards are removed for maintenance, DO NOT OPERATE the machine until all guards are reinstalled. Check clearance between the guards and the cutter before starting the machine.
5. **WORKPLACE SAFETY**: Keep the floor around the machine clean. Scrap material, sawdust, oil, and other liquids increase the risk of tripping or slipping. Be sure to clean up the table before starting the machine. Ensure the work area is well-lighted, and a proper exhaust system is used to minimize dust. Use anti-skid floor strips on the area where the operator normally stands and mark off the machine work area. Provide adequate workspace around the machine.
6. **ACCESS CONTROL** should be enforced so only trained personnel can access the work area and operate the machine. Make use of the childproof safety feature of the power switch when available.
7. **NEVER STAND ON THE MACHINE**. This prevents injuries from tipping-related accidents and accidental contact with cutters.
8. **REPLACEMENT PARTS**: Use only genuine Oliver Machinery replacement parts and accessories recommended for this machine. Generic parts made by other manufacturers may create a safety hazard and WILL void the factory warranty and other guarantees.
9. **ADDITIONAL SAFETY INFORMATION**:
  - National Safety Council – *Accident Prevention Manual for Business and Industry*: <https://shop.nsc.org/apm-admin-program-14ed>
  - ANSI O1.1: <https://webstore.ansi.org/standards/wmma/ansio12013>
  - OSHA 1910.213: <https://www.osha.gov/laws-regs/regulations/standardnumber/1910/1910.213>

### \*\*\* ATTENTION \*\*\*

Table saw specific safety guidelines are located in the section “Operation” (page 34). Familiarize yourself with all safety guidelines before using this saw!

# Electricals

	<b>Faulty electrical work can cause electrocution and is a fire hazard.</b>
<b>WARNING</b>	<b>All electrical work must be completed by a licensed electrician and must meet the local electrical code in your area. Otherwise, the warranty is void.</b>

## Minimum Circuit Size Required for Model 4065 Table Saw

<b>Stock Number</b>	<b>Voltage</b>	<b>Minimum Circuit Size Required</b>
<b>4065.002</b>	230V	25A
	460V	15A
<b>4065.003</b>	230V	35A
	460V	20A

Please ensure the electrical circuit for this machine meets the minimum circuit size requirement. The minimum circuit size requirement applies to a dedicated circuit that provides power to one 4065 Table Saw. If more machines are sharing the same circuit, consult a licensed electrician to ensure the designated circuit is properly sized for safe operation.

If a circuit is available but does not meet the minimum circuit size requirement listed above, a new circuit must be installed for this machine.

## Grounding

	<b>Improper grounding can cause electric shock, fire, and equipment damage.</b>
<b>WARNING</b>	

Proper grounding reduces the risk to the operator in the event of electrical malfunction or breakdown. This machine must be connected to the grounding conductor when available, and all grounding connections must meet or exceed the electrical code requirements in your area. Furthermore, all grounds must be verified and must meet or exceed the electrical requirement of the machine. For workshops that have an ungrounded 3-phase system, a ground detector must be present according to NEC 250.21(B). Consult a licensed electrician to ensure this saw can operate safely with this ungrounded system.

## Electrical Wiring

This machine must be wired to a power source before use.

To connect the machine directly to the electrical panel (“Hardwiring”), ensure an electrical disconnect is installed near the machine so the operator or service person can easily disconnect the machine from power.

To connect this machine with a plug and a cord, use a UL/CSA listed plug that meets the power requirements. Organize the power cord so it does not create a tripping hazard.

Refer to “Wiring Diagrams” on page 65 for wiring your machine to a power source.

Use the correct power cord type when connecting this machine to the power source. Use power cord types with a voltage rating of 600V for 460V circuits. In addition, the ampacity rating of the power cord or wires is determined by many factors. It is important to have the wiring work completed by a licensed electrician, and the work must meet or exceed the requirements of the local electrical code. Otherwise, the warranty is void.

Use a compatible strain relief to protect and secure the electrical wire at the exit hole of the connection box. Use a compatible conduit connector if the machine is wired with armored cables or conduit.

Use ring-type or fork-type connectors to connect the wires to the terminals of the table saw.

This saw uses a three-phase motor. If the motor is running in reverse, swap any two of the incoming hot wires in the junction box.



**Use properly sized wires that meet the power requirement of your machine. Using undersized wires can cause overheating and increase the risk of fire and machine damage.**



**Improper copper-aluminum wire connection is a fire hazard. If the power circuit available uses aluminum wires, use certified CU/AL wire connectors.**

The use of an extension cord is not recommended. If you need an extension cord to connect to a power source, select a durable cord type with a high-temperature rating (90C° or above). Use the minimum amount of extension cord as needed.

### Minimum cord size (AWG) required based on amperage draw and length of the cord:

<i>Amps</i>	<b>Power Cord Length</b>			
	25 feet	50 feet	75 feet	100 feet
<i>8 to 12</i>	14	14	12	10
<i>12 to 15</i>	12	12	10	10
<i>15 to 20</i>	10	10	10	NR
<i>21 to 30</i>	10	NR	NR	NR

\*NR: Not Recommended

## 230V/460V Conversion

The three-phase 4065 Table Saw variants are prewired to 230V in the factory and can be converted for 460V power sources. A licensed electrician must complete the rewiring work, or the warranty is void.

**WARNING:** This table saw's thermal relay must be replaced with the 230V/460V conversion. **Before conducting the voltage conversion work, contact Oliver Machinery to purchase the required parts and reconfirm the voltage conversion instructions.**

Refer to "Wiring Diagrams" on page 65 and complete the three steps for rewiring your machine to run at a 460V:

1. Rewire the motor.
2. The transformer fuse is behind the fuse panel. Relocate the transformer fuse to the "460V" position.
3. Replace the existing thermal relay with the new relay. The thermal relay is located inside the magnetic switch (#154 in the parts diagram). Set the overload amperage:
  - 9.5A @ 460V for stock # 4065.002 (7.5HP Motor).
  - 13.5A @ 460V for stock # 4065.003 (10HP Motor).

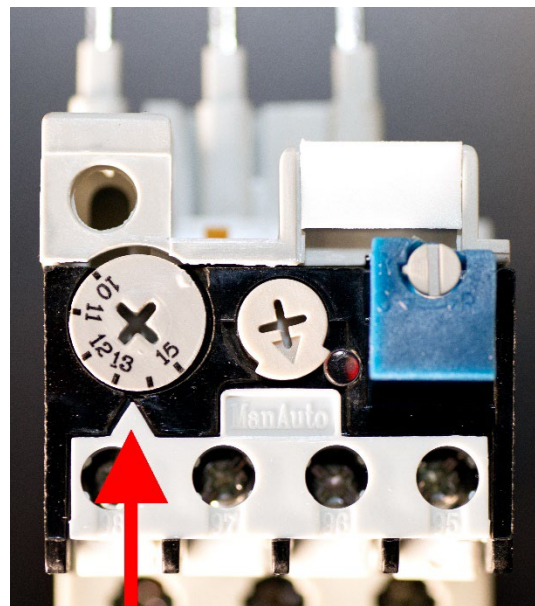
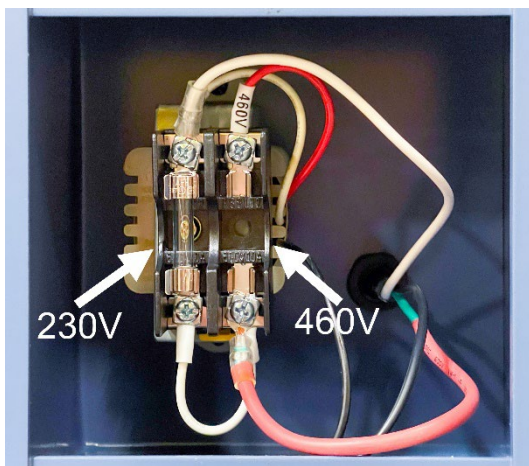

Deenergize the electrical circuit before touching any enclosed, electrified parts. Touching an electrified part WILL result in serious personal injury or death.



Faulty electrical work can cause electrocution and is a fire hazard. All electrical work must be completed by a licensed electrician and must meet the local electrical code in your area, or the warranty is void.



# Setup

## Shop Preparation

### Space Requirement

The dimensions of the table saw are 82"(L) x 48"(D). You will need additional space for manipulating your workpiece, auxiliary support table/rollers, electrical connection, and dust collection.



### Load Limits

The entire shipment has a shipping weight of 1092 lbs., and the fully assembled table saw has a net weight of 814 lbs. Please ensure all lifting tools and building structures have adequate load capacity for transporting and supporting the total weight of this machine, the operator, and related items.

### Electricals

Make sure a properly sized circuit and electrical outlet are available near the machine. Please refer to "Electricals" on page 14 for details regarding electrical requirements.

### Lighting

Adequate lighting is needed to operate this machine. Overhead, non-glare lighting should be installed.

### Safety Labels

If this machine introduces a new safety hazard to your workplace, please display proper warning signs in highly visible locations.

### Dust Collection

Wood dust created by this table saw is a health hazard. Connect this machine to a dust collection system. Check air suction strength regularly to ensure dust and shavings are effectively removed. High-quality dust masks should be available for using the table saw.



**Air resistance and leakage in a dust collection system will impact its effectiveness. Use a dust collection system that is rated above 500 CFM at the dust port. Doing so improves air quality in the workplace and prevents the machine from jamming.**

## Receiving

Your shipment should arrive in multiple packages. Upon receiving your shipment, please verify all packages are delivered. Check for any significant damages before signing the delivery confirmation.

### IMPORTANT

If items are missing or damaged, please call us immediately at **1-800-559-5065**

The entire table saw shipment comes in four wood crates:

1. Table saw main unit with accessories.
2. Table saw fence assembly.
3. Extension table assembly.
4. Table saw rail assembly.



### Moving the shipment into the shop

Your machine will be delivered by freight service, and it will be left outside of your workshop by default. On the day of delivery, please be sure help is available to move the machine to its final location.



#### WARNING

The total weight of the 4065 Table Saw shipment is 1092 lbs, and the fully assembled saw weighs 814 lbs. Safe moving techniques and proper lifting equipment are required, or serious personal injury may occur.



#### WARNING

Your packages may be secured by the straps. Do not lift your packages by the strap. They are not designed to hold the total weight of your package. They may snap without warning and cause serious injury and machine damage.

## Unboxing & Inventory



**Always wear safety goggles and gloves when removing packing straps that secure the package. Straps may spring back violently when released and cause injury.**

### Crate #1

The table saw crate contains the saw and a box with accessories:

#### Blade Guard Assembly

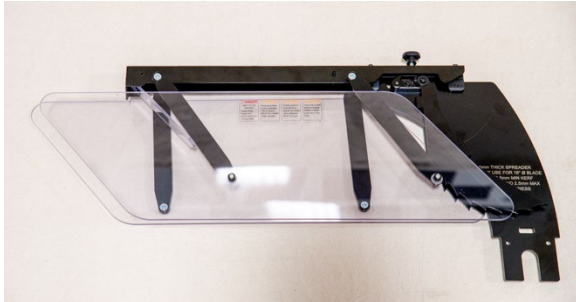

#### Miter Gauge



#### Push Stick



#### Arbor Wrench (x2)



#### Handwheel Handle



#### Hand Tool Kit for Assembly

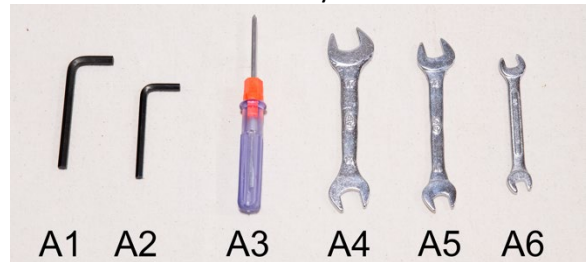

Item	Description	QTY
A1	6mm Hex Key	1
A2	5mm Hex Key	1
A3	Phillips Head Screwdriver	1
A4	14/17mm Combo Wrench	1
A5	11/13mm Combo Wrench	1
A6	8/10mm Combo Wrench	1

### Crate #2

The fence crate contains the fence and the handle:



### Crate #3

The extension table crate contains the tabletop, legs, crossbars, leveling feet, and mounting hardware.

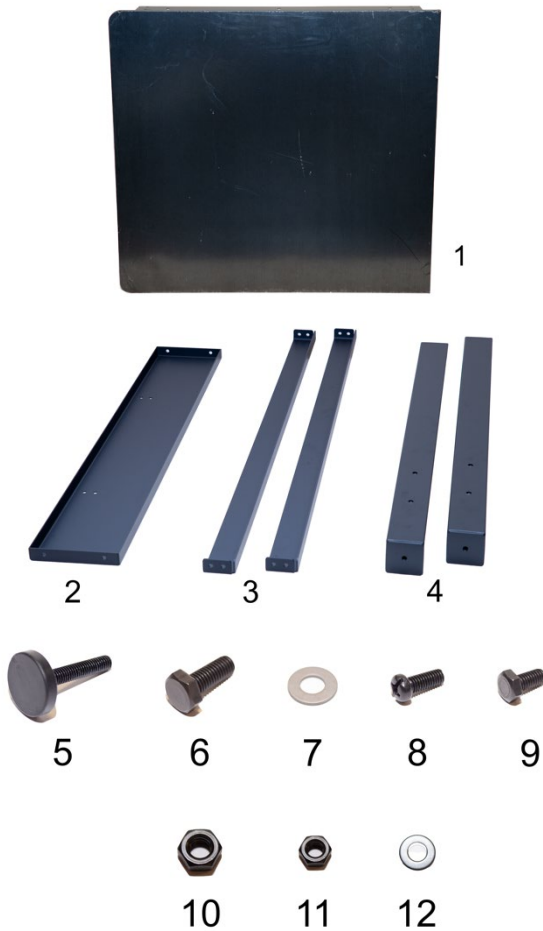

Item	Description	QTY
1	Extension Table	1
2	Shelf End Plate	1
3	Shelf Brackets	2
4	Table Legs	2
5	Leveling Feet	2
6	M10 Hex Bolts	3
7	M10 Flat Washers	3
8	M8 Phillips Head Screws	12
9	M8 Hex Bolts	8
10	M10 Nuts	2
11	M8 Nuts	4
12	M8 Flat Washers	20

### Crate #4

The table saw rails crate contains the front rail, rear rail, and mounting hardware.



Item	Description	QTY
13	Front Rail	1
14	Rear Rail	1
15	Fence Tube	1
16	M8 Flat Head Hex Screw	7
17	M8 Socket Head Cap Screw	7
18	M6 Hex Bolt	8
19	M8 Nut	10
20	M8 Spring Washer	16
21	M6 Spring Washer	8
22	M8 Flat Washer	17
23	M6 Flat Washer	8

**NOTICE:** If you cannot find an item in the list above, please check if it is still attached to the packaging. Occasionally, the item may have been pre-installed in the factory. See “Parts List” to check if a component is included or installed.

**NOTICE:** This machine comes with various standard-sized, non-proprietary parts. If any of these parts are missing, we are happy to deliver them to you. To have the machine up and running as soon as possible, you can also find these parts at your local hardware store.

## Additional Items Recommended for Machine Set Up

<i>Item</i>	<i>Purpose</i>
Safety glasses and hearing protection	Protection
Disposable gloves	Protection and cleaning
Lifting Straps	Lifting the table saw main unit.
Forklift / Hoist / Crane	Lifting the table saw main unit.
Paper Towel	Cleaning
WD-40	Cleaning
Rust Inhibitor	Cast iron table top rust protection.
Machinist Square / Combination Square / 1-2-3 Block	Calibration
45° Machinist Square / Protractor / Quick Square	Calibration
Dial Indicator with Miter Slot Compatible Base	Calibration

### Lifting Table Saw Main Unit from Pallet

Connect the lifting slings to the lifting hooks and ensure the slings are balanced, then lift the main unit from overhead.

Lower the table saw gently to the floor to prevent damaging the casters and the cabinet, then move the main unit to the designated location for operation.



### Cleaning

To prevent rusting during shipment, the unpainted cast iron surface of the saw is covered with rust protectant and plastic film. Remove the plastic film and wipe off the rust protectant with paper towels. Make sure to clean the hard-to-reach areas, such as the miter tracks and the areas around the table insert. WD-40 can thin the rust protectant to make it easier to remove.

Once all rust protectant is removed, routinely coat the table with rust preventives such as Boeshield® T-9 or paste wax. Do not use rust preventives that contain silicone, which is known to interfere with certain finishes and glues.

Excess oil on the saw blade and the fence tube should be removed as well.

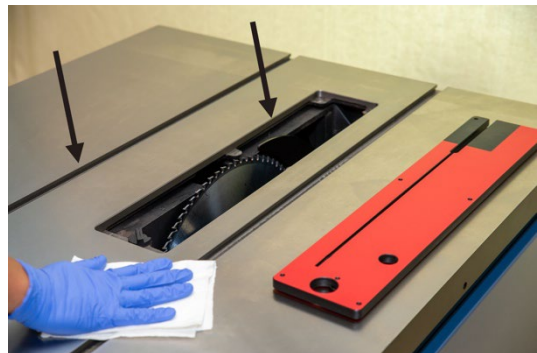

## Leveling Main Unit

The cast iron tabletop of the saw should be level with the floor. This makes it easier to extend the saw table and set up auxiliary support devices when needed. After the saw main unit is situated at its designated location, lower the anti-vibration leveling feet by turning the red dial counterclockwise. Adjust the leveling feet until the saw table is level with the floor and the main unit is not rocking on the floor. The saw must stay stationary while it is in use.

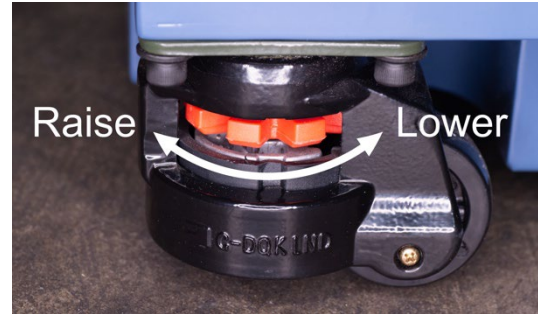

## Essential Mechanical Inspections Before Assembly

This table saw has been tested and calibrated before leaving the manufacturing facility. It should not require extensive adjustments. The essential checks provide an opportunity to get familiarized with the saw, and it helps to discover any potential issues before the final assembly.

If issues were found from the inspections, please refer to “Maintenance” on page 55 and “Troubleshooting” on page 61 to correct the issues.

**⚠ WARNING ⚠**

**Disconnect the table saw from the power source before inspection! Failure to do so can result in serious injuries.**



**⚠ CAUTION ⚠**

**The inspection involves moving the saw blade. Wear thick leather gloves to prevent injuries from accidental blade contact. Remove the gloves before operating the saw.**



## Test 1: Trunnion Inspection

1. Install the handle of the blade tilt handwheel located on the left side of the table saw cabinet. Check the blade tilt angle pointer in front of the saw to make sure the blade tilt is set to 0°. Loosen the blade tilt handwheel knob, and make adjustments as needed.



2. This saw should arrive with the saw blade and riving knife pre-installed. If not, see the steps in “Changing Saw Blade” on page 39 and “Swapping Riving Knife / Blade Guard” on page 40.

The zero clearance table insert should have been cut and ready to use, and it should be flush with the table. If not, see “Table Insert Setup” on page 59.

3. Remove the table insert.



4. Loosen the blade height handwheel knob and raise the blade to the maximum height.

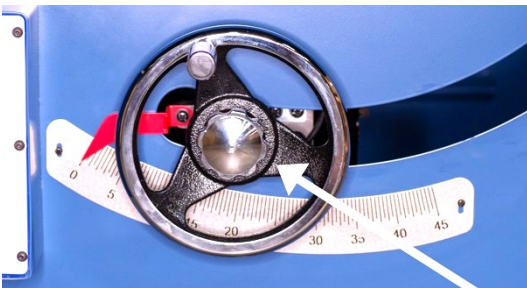

5. Make sure the blade is mounted securely on the arbor and the blade can be raised to the maximum height. When using a 16” blade, the blade height is 6-1/8” above the table. The blade height is 5-1/8” when using a 14” saw blade.

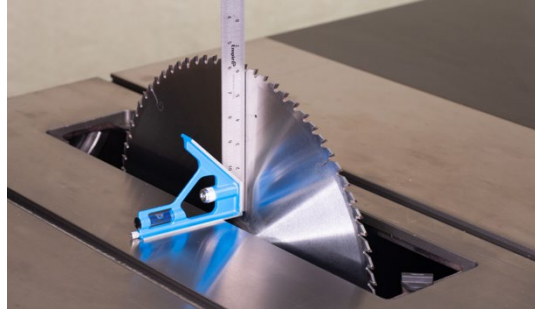

6. Make sure the riving knife is seated correctly on the mounting bracket. The holes on the riving knife must align with the pins on the bracket, and the riving knife must be secured by the flange and the mounting bolt.

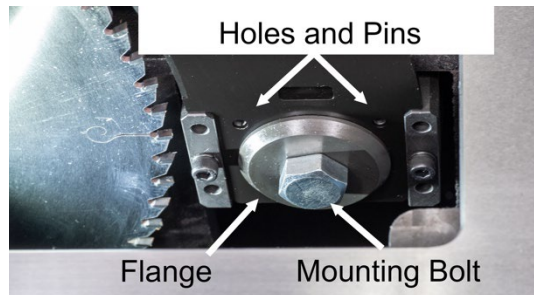

7. Set blade tilt to 45°. The highest point of a 16” blade is 4-3/8” above the table. For a 14” blade, the blade height is 3-5/8”.

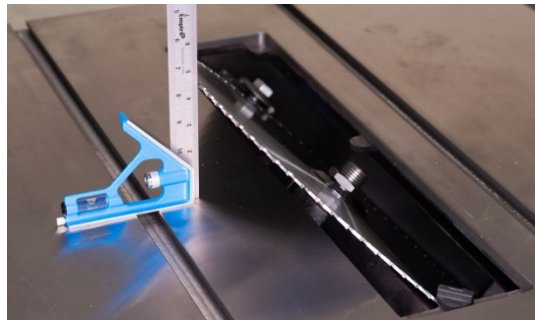

8. Lower the blade to the lowest position, then reinstall the table insert. Raise the blade to maximum height again. The table insert must not contact the blade at any blade height and any blade tilt angle.

## Test 2: Blade / Miter Slot Alignment Inspection

1. Raise the blade to the maximum height and set the blade tilt angle to 0°
2. Mark the saw blade near the edge to set a reference point. Move the reference point towards the front of the saw, then measure the distance between the blade and the miter slot.

Using a dial indicator with a base that glides along the miter slot will result in a more accurate measurement.

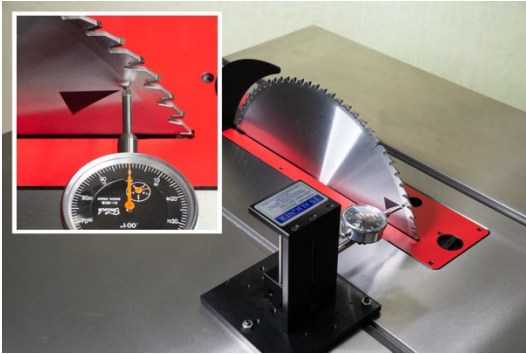

If a dial indicator is not available, a combination square can be used as an alternative.

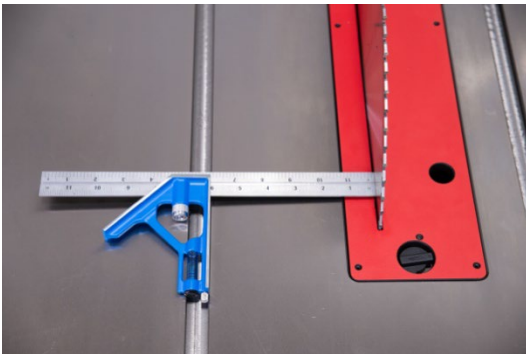

3. Move the reference point towards the rear of the saw and measure the distance.

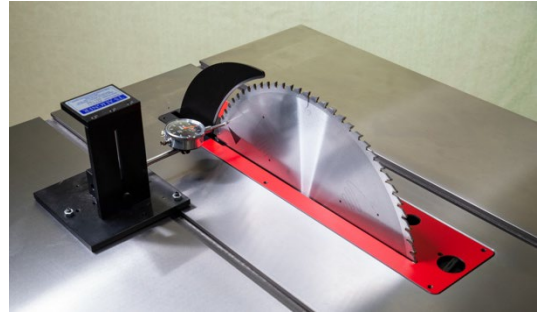

4. If the blade is perfectly aligned with the miter slot, the distance measured at the front and the back should be the same. If the offset is greater than 0.008" (1/128"), refer to "Blade to Miter Slot Alignment" on page 48 and make adjustments.



### Test 3: Riving Knife Alignment Inspection

1. Place a straight edge across the table opening and against the saw teeth. Make sure the riving knife is in parallel with the blade and it is staying within the alignment zone. Repeat the check on the other side of the saw blade.

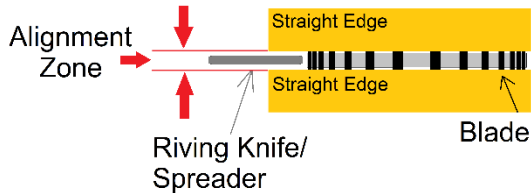

The alignment zone represents the slot of a workpiece cut by the blade. If the riving knife drifts beyond the alignment zone, it will either catch the workpiece or push the workpiece sideways. This will increase the risk of kickback and impact cut quality.

2. Check the height of the riving knife. It needs to be 1-5mm (approx. 3/64" - 13/64") BELOW the saw blade. This ensures the riving knife does not catch the workpiece and provides maximum protection against kickback.

**Height Difference:  
1-5mm (3/64" - 13/64")**

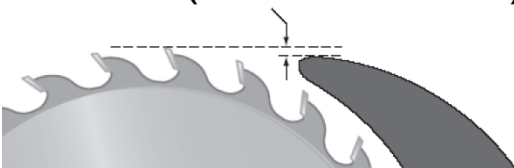

3. Check the distance between the riving knife and the saw teeth. It should have a clearance between 3-8mm (approx. 1/8" - 5/16"). This ensures there is enough room to clear the sawdust and wood chips.

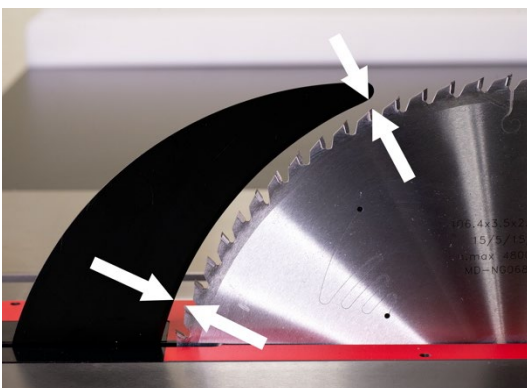

### Test 4: Spreader Alignment Inspection

1. Remove the riving knife and install the blade guard assembly. Make sure the pins on the mounting bracket fit through the holes on the spreader.

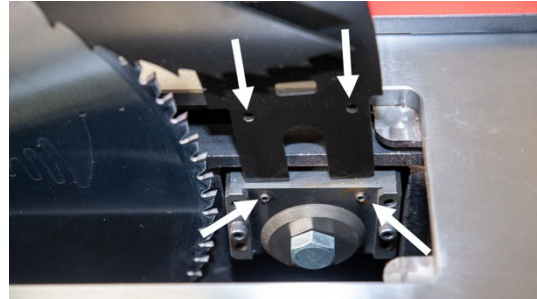

2. Loosen the blade guard locking knob and remove the blade guard.

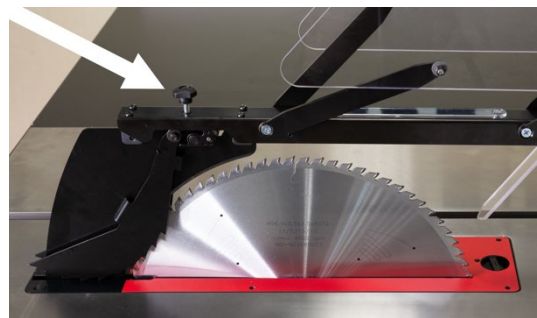

3. With only the spreader mounted, use a straight edge to verify the spreader aligns with the blade and stays within the alignment zone.

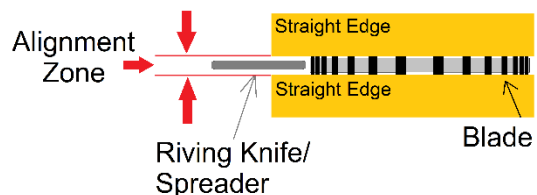

4. Reinstall the blade guard and lower the blade completely before conducting the motor and switch test.

## Electrical Connection and Tests

After the table saw passes the essential mechanical inspections, refer to “Electricals” on page 14 and “Wiring Diagrams” on page 65 to connect the table saw to the power source, then continue with the tests below.



**WARNING**

**This table saw is a heavy-duty, industrial-grade machine. The electrical work must be completed by a licensed electrician and meet the local electrical code requirements. Failure to comply can create lethal electrical and fire hazards and void this machine’s warranty.**

### Test 5: Motor and Magnetic Switch Functionality

1. Put on safety goggles and ear protection.
2. Insert and turn the key to “ON” position.



3. Reset the emergency stop button by rotating it clockwise until it pops up.



4. Press the green “START” button to turn on the saw. The table saw should run smoothly with minimum vibration.



5. Press the emergency stop button. The blade should gradually come to a stop. Observe the rotation direction of the blade through the table insert. Illuminate the blade with a flashlight as needed. If the saw blade runs in reverse, swap any two of the incoming hot wires in the junction box. See “Electricals” on page 14 and “Wiring Diagrams” on page 65 for details.
6. Reset the emergency stop button and start the saw again.
7. Disconnect the saw from power. Wait for a few seconds until the motor comes to a stop, then reconnect the saw to power. The saw should not start. The magnetic power switch turns off automatically when the saw is disconnected from power. The saw will only turn on again when the operator presses the “ON” button.
8. Press “STOP” to turn off the saw. The motor should come to a stop.
9. Reset the emergency stop button and lock the saw by turning the key to “OFF” position. Press the START button, and the saw will not start.
10. Rotate the key to the “ON” position again and press the START button, and the saw will start.
11. Press “STOP” to turn off the saw, then disconnect the saw from power for assembly.

# Assembly



This is an industrial grade saw, and the parts to be assembled are heavy. Please handle the parts with care and wear protective footwear. Heavy parts should be handled by two or more people to avoid injuries.

## Rails and Extension Table Installation

1. Gather the mounting hardware that comes with the rails package.



2. Align the screw holes on the front rail and the table.



3. With help from another person, mount the front rail to the table. Insert the flat head hex screw (#16) through the front rail screw holes, then insert the M8 flat washer (#22), M8 spring washer (#20) and hand tighten the M8 nut (#19) from the other end. Do not fully tighten the fasteners yet.
4. Tighten the nut on the right side of the table and measure the distance between the tabletop and the front rail top surface.

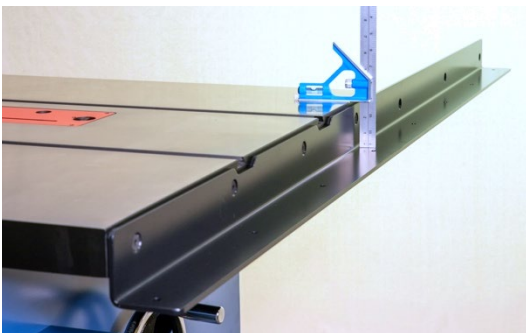

5. Adjust the left end of the front rail so the front rail runs in parallel with the table, then tighten the rest of the fasteners.



6. Align the screw holes on the back of the table and the rear rail.



7. With help from another person, mount the rear rail. Insert the M8 spring washer (#20), M8 flat washer (#22) into the cap screw (#17), then insert the cap screw through the screw hole. On the other end of the screw, insert the flat washer (#22) and hand tighten the M8 nut (#19). Do not fully tighten the fasteners yet.
8. Tighten the fastener on the left side of the table and measure the distance from the table to the top surface of the rear rail.
9. Adjust the other end of the rear rail to ensure it runs parallel with the table, then tighten all fasteners.

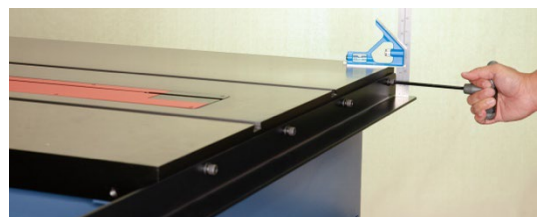

- Gather the mounting hardware that comes with the extension table package and the remaining fasteners for rail installation.



- Thread the entire length of the leveling feet (#5) into the table legs (#4).



- Insert the flat washer (#7) into the M10 bolt (#6). There are three sets of these fasteners. Thread them on the right side of the saw table. Leave a gap between the washer and the table for hanging the extension table frame.



- With the help of two other people, hang the frame of the extension table onto the M10 bolt. Make sure the frame sits in between the table and the flat washer.

- Insert the flat head hex screws (#16) through the front rail screw holes. On the other end of the screw, insert the M8 spring washer (#20), M8 flat washers(#22) and hand tighten the M8 nuts (#19).

- Insert the M8 spring washer (#20), M8 flat washer (#22) into the cap screw (#17), and then insert that into the rear rail screw holes. On the other end of the screw, insert the flat washers (#22) and hand tighten the M8 nuts (#19).

- At this point, the extension table is loosely mounted. Mount the extension legs onto the extension table frame. Insert the spring washers (#21) and flat washers (#23) into the eight M6 hex bolts (#18) available, then thread them through the table frame's screw holes and into the tapped screw holes on the leg. Tighten all bolts.

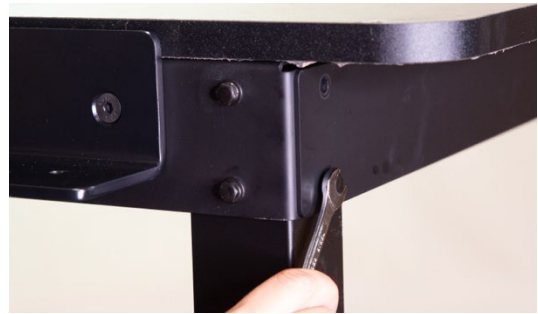

- Remove the protective film of the extension table.

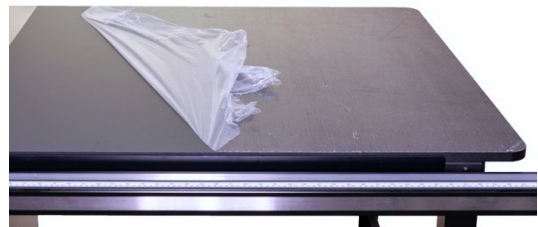

- Adjust the height of the extension table. Use a long straight edge to ensure the extension table runs flush and coplanar with the cast iron table, then tighten all fasteners to secure the extension table.



19. Adjust the leveling feet of the extension table legs so they provide adequate support for the table without changing the levelness of the table.



20. Mount the shelf end plate (#2) onto the extension table legs using the M8 Philips screws (#8) and M8 flat washers (#12). Orient the shelf end plate so the screw holes of the shelf brackets are close to the floor, as shown in the picture.



21. Mount the shelf brackets (#3) using the remaining M8 Philips screws (#8), spring washers (#20), flat washers (#12), and nuts (#19).



Please note that the screw holes on the cabinet may be covered by decorative stickers. Remove a small section of the sticker to reveal the screw hole.



22. Mount the fence tube (#15). Align the screw holes of the front rail and the fence tube. Mount the fence tube with the M6 bolts (#18), M6 spring washers (#21), and M6 flat washers (#23). Make sure the fence tube runs in parallel with the edge of the table before tightening all bolts.



## Fence Setup

1. Install the fence handle.



2. Mount the fence onto the front rail.



3. Make sure the fence aligns with the miter slot. Using a dial indicator with a miter slot compatible base to check the alignment will result in a more accurate measurement.

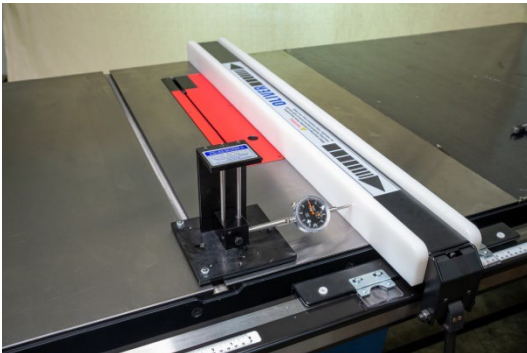

4. If a dial indicator is not available, check the alignment using a combination square.



5. Refer to "Fence to Miter Slot Alignment" on page 49 for details about checking and readjusting the fence to miter slot alignment.
6. Use a square to verify the fence face is perpendicular to the table. Refer to "Fence Squareness Adjustment" on page 50 if adjustment is needed.



7. The fence should flow on top of the cast iron table and only be supported by the front rail and the glide plate near the rear of the fence. Use a feeler gauge or a piece of cardboard to make sure there is a gap of approximately 1/16" between the fence face and the table. Refer to "Fence Height Adjustment" on page 50 if adjustment is needed.



8. Raise the blade and slide the fence until it is barely touching the blade.

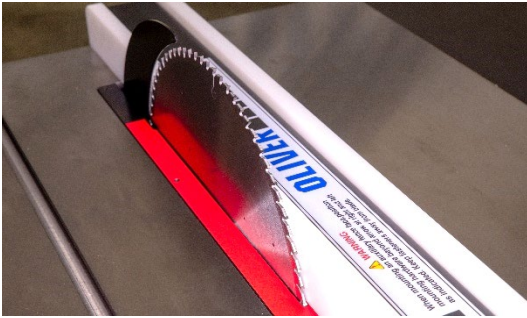

9. Check the readings on the scale to see if the reading is 0". If so, the fence is set up. Otherwise, see "Fence Scale Adjustment" on page 51 for adjustments.



10. Repeat the same test to check the scale for ripping left of the blade.

## Dust Collection

The use of the table saw will generate wood dust, which is harmful to the body. This saw comes with a dust shroud to capture the dust. Connect this machine to a dust collection system to prevent the dust shroud from getting clogged.

The minimum CFM requirement for this table saw is 500 CFM at the dust port, which means the dust collection system should have a rating greater than 500 CFM, as air friction and leakage can reduce effective CFM at the dust port.



### **IMPORTANT**

**Running this table saw without a dust collection system or using a dust collection system with inadequate suction may damage the machine and cause other hazardous situations. Check the dust shroud and the dust collection system regularly to make sure it is not jammed or filled up.**

## Moving and Leveling the Saw

This table saw is equipped with casters, and it can easily be moved around.

To move the saw, lift up all six leveling feet to the highest position and move the saw with the casters.

To keep the saw stationary and leveled, lower the leveling feet until the casters are lifted off from the floor. Continue to adjust the leveling feet until the table is leveled with the floor and the saw is not rocking. Then adjust the leveling feet of the extension table to make sure they support the far end of the extension table. Lastly, try to push the saw and make sure it stays stationary. The saw must not move during operation.

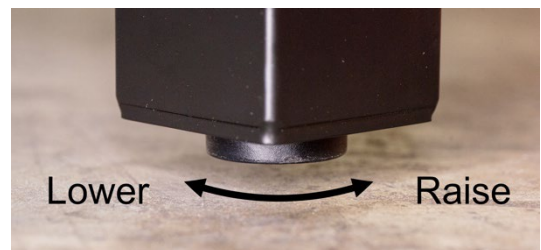
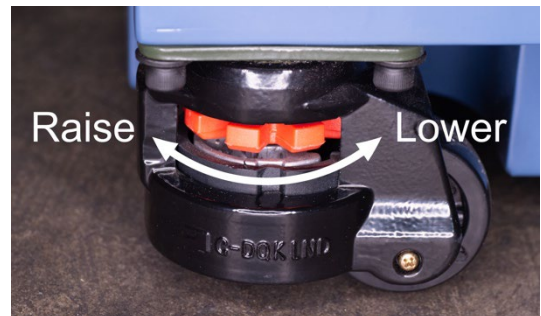



# Accessories

*14" Blade Conversion Kit (Part #: 4065.A001) &  
16" Blade Conversion Kit (Part #: 4065.A002)*

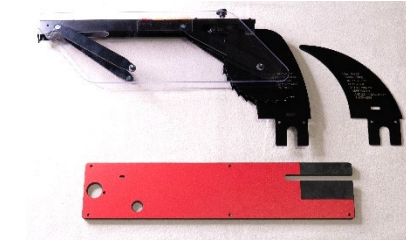

The blade conversion kit allows the table saw to adopt a different blade size for different applications. The kit comes with a riving knife and blade guard assembly that matches the saw blade's diameter to maximize the protection against kickback. It also includes a brand new zero clearance table insert.

*Zero-Clearance Table Insert (Part #: 4065.A003) &  
Zero-Clearance Dado Insert (Part #: 4065.A004)*

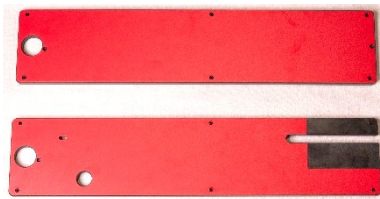

Zero clearance table inserts help reduce chip-outs and splintering. They also improve safety by preventing thin cuts and debris from getting trapped between the blade and the insert. Use a zero-clearance insert that matches the kerf of the saw blade.

These OEM table inserts are made of high-density phenolic, which is durable and stable for temperature and humidity changes.

## *Touchup Paint*



Keeping all painted surfaces in good condition not only makes your machine look nice but also keeps rust away. Oliver Machinery has pre-mixed spray paint available in Oliver-Blue for purchase.

Accessories are available on our website: **OLIVERMACHINERY.NET**

To order by phone, please call us at **1-800-559-5065**. We are available Monday through Friday, 7:30 AM - 4 PM Pacific Time. You can also email us at **PARTS@OLIVERMACHINERY.NET** to purchase accessories.

Please visit our website at **OLIVERMACHINERY.NET** for additional recommended accessories.



**Using unapproved accessories may cause the machine to malfunction, which can result in serious injury and/or machine damage. Only use accessories recommended for this machine.**

# Operation

The table saw is recognized as one of the most dangerous tools in the shop, and it should be treated with respect. This chapter provides general guidelines for operating a table saw safely. It is not intended as a substitute for formal woodworking training. Additional safety rules may be required to fit specific needs in various situations. When in doubt, please consult credible training resources for help.

 **WARNING** Similar to many other types of woodworking machinery, this table saw is **NOT** equipped with an emergency braking device that stops and retracts the saw blade upon contact with the human body. Operators must take all safety measures to **AVOID BLADE CONTACT**. Otherwise, serious injuries such as amputation or even death may occur.

 **WARNING** Kickback is another common cause of table saw accidents. Whenever possible, **USE ANTI-KICKBACK DEVICES** such as a blade guard or riving knife when using the table saw. Avoid standing in front of the saw blade to reduce the chance of getting stuck by a kickback projectile. Kickback accidents can cause serious injuries or even death.

### Safety Guidelines for Preparing for a Cut

- 1. **KEEP THE SAW STATIONARY:** Make sure to lower all six leveling feet to keep the table saw stationary for operations. If the saw wobbles on an uneven floor, adjust the leveling feet to keep it stable.

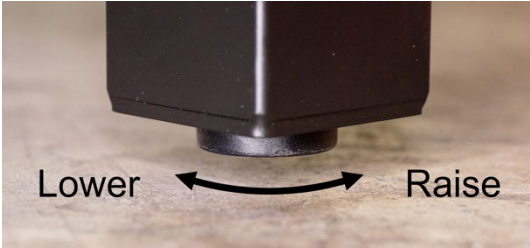
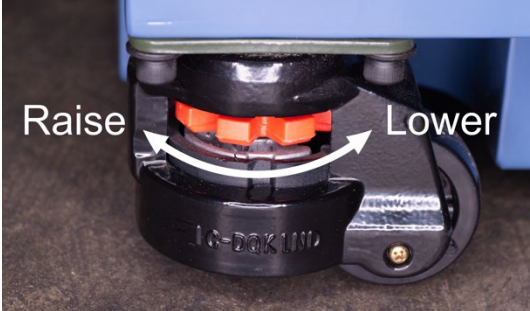

- 2. **INSPECT SAW BLADE:** The saw blade must be sharp, clean, balanced, and free of damage. A damaged saw blade can disintegrate while the saw is running and become a deadly projectile. Replace the saw blade when it is damaged, dropped, or dull. Forcing a dull blade to work invites accidents and impacts finish quality.



- INSPECT MATERIAL:** This table saw is designed for cutting natural and engineered wood materials. It can also cut non-shattering plastics with a high melting point. Make sure the material for cutting is dry, stable, intact, and free of foreign objects such as nails. The workpiece must have flat and stable surfaces for feeding safely against the table plus the fence or miter gauge.

**⚠ WARNING ⚠**

**DO NOT use this table saw to cut metal.**

**DO NOT cut any materials, such as ceramic tiles, that can disintegrate when it is cut.**

**Failure to comply will greatly increase the risk of accidents that can cause serious injuries or death.**

- INSTALL BLADE GUARD** for through cuts whenever possible. A through cut is to cut through the entire thickness of a workpiece. The blade guard is equipped with anti-kickback paws. It will stop or slow down the workpiece from shooting back toward the operator. Make sure the blade guard is securely fastened with the flange and bolt. Also, the spreader must align with the blade and be positioned in the alignment zone. Replace/repair the blade guard when it is damaged.

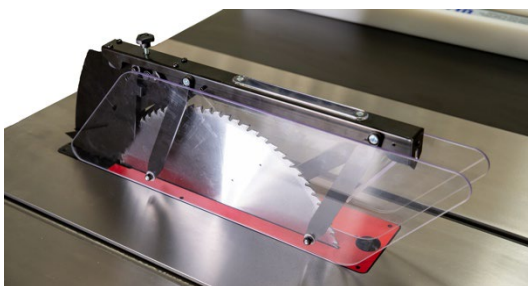

- INSTALL RIVING KNIFE** for non-through cuts or when it is impossible to use the blade guard for a through cut. The riving knife prevents kickback by preventing a workpiece from latching onto the back of the spinning saw blade. Make sure the riving knife is inserted completely into the mounting bracket and fastened. It must align with the blade and position within the alignment zone.

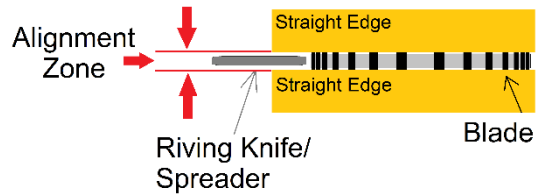

- CHANGING SAW BLADE:** Always disconnect the table saw from power before changing the saw blade. Failure to do so can result in amputation or death if the saw is accidentally turned on.

Only use saw blades that are sharp, clean, balanced, and free of defects. Choose the blade type that is designed for the material and the type of cut.

- BLADE ADJUSTMENTS:** Only adjust the blade height or blade tilt when the saw is off and the saw blade comes to a complete stop. The blade height should be 1/4" more than the thickness of a workpiece.

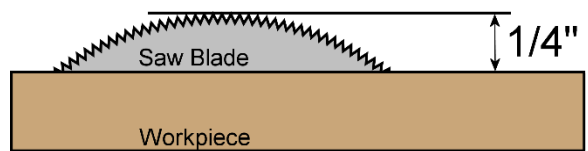

After blade adjustments, make sure the blade is not in contact with the blade guard, riving knife, table inserts, fence, and/or the workpiece. Some zero-clearance table inserts only work at a specific bevel angle and may catch the blade at a different angle.

8. **FENCE SETUP:** Check fence alignment against the blade and miter slot before using the saw for the first time, then perform routine checks afterward. The workpiece can bind with the saw blade if the distance between the fence and the blade in the front is GREATER than the distance in the rear. This will cause the workpiece to bind with the blade and increase the risk of kickback.

The fence must be in parallel with the saw blade and the miter slot or have an offset of less than 1/64" to the right when measuring at the rear of the table.

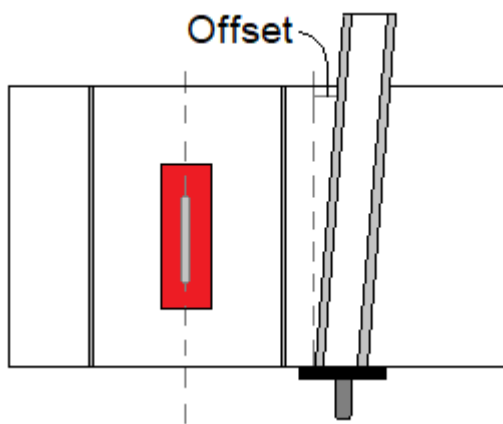

ALWAYS lock the fence and make sure the fence is not touching the blade before starting the table saw.

9. **MAKING CROSS CUTS** using a miter gauge allows stable feeding and reduces the risk of kickback accidents.

**NEVER** use the fence as the stop block when cutting with a miter gauge, as this allows a workpiece to bind with the blade and increases the risk of kickback.



10. **CUTTING ODD SHAPE WORKPIECES:** Avoid cutting odd-shaped workpieces on a table saw whenever possible. To cut an odd-shaped object, it must be securely fastened on a special jig that allows the operator to feed the workpiece safely.

11. **DADO BLADES:** When installing dado blades, make sure all saw blade teeth are distributed as evenly as possible. Never allow the saw blade teeth to stack on each other, as that can bend the dado blades and alter the width of cut.

12. **SUPPORT LONG/WIDE WORKPIECE** with rollers or other devices on both infeed/outfeed sides of the saw to avoid injuries.

13. **REHEARSE A CUT,** especially for cutting large/wide workpieces, to ensure there is enough room to clear the workpiece. Also, make sure the workpiece and the cutout are supported throughout the entire cut.

14. **EYE PROTECTION:** Always wear an approved safety face shield, goggles, or glasses that comply with ANSI Z87.1 and CSA Z94.3 standards. Common eyeglasses are not safety glasses and may not provide adequate protection.

15. **EAR PROTECTION:** Use hearing protective devices where the noise exceeds the level of exposure allowed in section 1910.95 of the OSHA Regulations. When in doubt, use it.

Duration Per Day, Hours	Sound Level Dba Slow Response
8	90
6	92
4	95
3	97
2	100
1½	102
1	105
½	110
¼ or less	115

16. **OTHER PERSONAL PROTECTION:** Before using the table saw, remove the tie, rings, watch, and other jewelry. Roll up sleeves above the elbows. Remove all loose outer clothing and confine long hair. Protective footwear should be used. Do not wear gloves when operating the table saw. Wear gloves to perform maintenance work when the saw is unplugged.
17. **DUST HAZARD:** Connect the table saw to a dust collection device and enable dust collection before work begins. Wear a dust mask to prevent inhalation of harmful wood dust. Avoid cutting wood species that are known to trigger allergic reactions.
18. **ADDITIONAL ANTI-KICKBACK DEVICES,** such as featherboards or anti-kickback rollers, can prevent kickback or slow down the projectile when they are properly installed.
19. **PROPER USE:** Do not use this machine for anything other than its intended use. If used for other purposes, Oliver Machinery disclaims any real or implied warranty and holds itself harmless for any injury or damage which may result from that use.

## Safety Guidelines for Using the Table Saw

1. **STAY ALERT** at all times. Do not operate this machine while under the influence of drugs/alcohol or when not feeling well.
2. **HAND POSITIONING:** Keep hands and any body parts at least 6" away from the saw blade. Using a push stick can keep hands away from the saw blade while maintaining control of the workpiece.
3. **STANCE AND BODY POSITIONING:** Maintain a balanced stance and never reach over the saw blade while feeding a workpiece.
4. **PREVENT KICKBACK INJURIES:** Avoid standing right in front of the saw blade when feeding a workpiece. Failure to do so exposes the body to the fast-traveling projectile when kickback occurs, and this can result in serious injuries or death.
5. **USE PROPER FEEDING TECHNIQUE:** Allow the saw blade to reach full speed, then feed the workpiece at a speed that allows the blade to make a clean cut without burning the cut edge. Feed the workpiece securely against the table plus the fence, miter gauge, or other support jigs. The feeding direction must be parallel with the blade.
6. **BAD FEEDING TECHNIQUES** will greatly increase the risk of accidents and must be avoided:
  - **NEVER** perform freehand cuts.
  - **NEVER** feed a workpiece sideways.
  - **NEVER** pull a workpiece from behind the blade.
  - **NEVER** rotate the workpiece toward the rear of the blade while feeding.
  - **NEVER** back out a cut. If it is impossible to complete a cut, stop the saw while holding the workpiece securely, then remove the workpiece after the blade comes to a complete stop. If the guard must be removed to back out a piece, promptly reinstall the guard afterward.
  - **NEVER** reach behind or over the blade while feeding.
  - **NEVER** perform plunge cut, except for preparing a zero-clearance table insert (See page 59 for details). Extra caution must be taken.
7. **REMOVING CUTOFFS** frequently when making multiple repeating cuts. ALWAYS turn off the saw and wait for the blade to come to a complete stop before removing cutoff pieces. Failure to do so can cause kickback accidents and/or allow a cutoff piece to get caught in between a running blade and the table insert.
8. **DADO/RABBET CUTS:** Blade guard / riving knife has to be removed when cutting a dado or rabbet. Extra caution must be taken to avoid blade contact and kickback accidents. To avoid kickback accidents, a deep non-through cut can be done in multiple light passes.

## Changing Saw Blade



Please wear thick gloves to protect your hands when changing saw blades. The saw blade teeth are sharp and can easily cut through the skin when not protected.

1. Disconnect the saw from the power source.
2. Unlock and remove the table insert.



3. Raise the blade to the maximum height and set the blade tilt to 0°.
4. While standing in front of the table saw, take one arbor wrench and insert it into the slot on the left side of the blade. Rotate the arbor until the wrench catches the arbor.

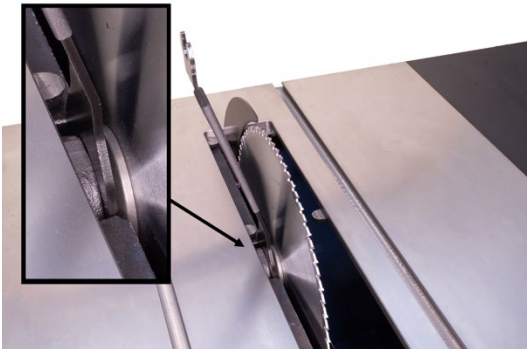

5. Hold the wrench in the left hand to stop the arbor from rotating, then loosen the arbor nut with the wrench in the right hand. Pull the wrench towards the front of the saw (rotate counterclockwise) to loosen the nut.



6. Remove the arbor nut, flange, and blade. Handle the blade carefully to prevent injuries.
7. Install the saw blade of choice. Pay attention to the orientation of the blade teeth. Do not install the blade in reverse.
8. Install the flange. Make sure the wider base is facing the blade.
9. Install and tighten the arbor nut with the arbor wrenches.

### IMPORTANT

Do not over tighten the arbor nut, as it is self-tightening. Over-tightening the nut will make it difficult to remove in the future, and it can also damage the saw.

10. Reinstall the table insert and blade guard after changing the saw blade.

## Swapping Riving Knife / Blade Guard

This table saw is equipped with a blade guard and a riving knife. These anti-kickback devices significantly reduce the chance of kickback accidents. Unless for making a dado cut, one of these devices should be mounted for operations.

1. Disconnect the saw from the power source.
2. Unlock and remove the table insert.



3. Raise the blade to the maximum height and set the blade tilt to 0°.
4. Loosen the mounting bolt to swap the riving knife/spreader.

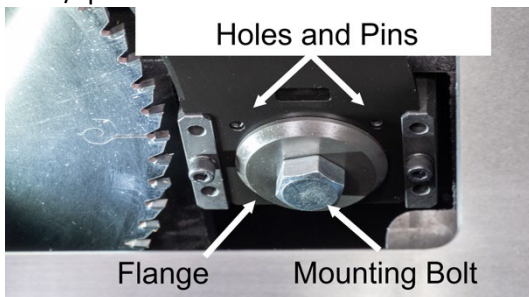

5. When installing a different anti-kickback device, make sure the pins on the mounting bracket fit through the holes of the device installed. Tighten the mounting bolt to secure the device.

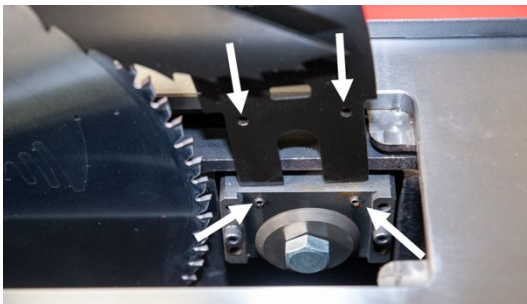

6. Reinstall the table insert.

## Using the Digital Readout

This table saw comes with digital blade elevation and blade tilt readout:

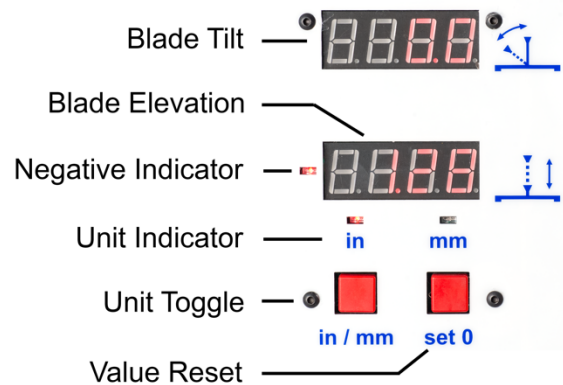

- To reset the blade height indicator to zero. Short press the “set 0” button.
- To reset the blade tilt indicator to zero. Hold the “set 0” button until the value is reset.
- The negative value indicator lights up when the blade height value is negative.
- **NOTE:** All values will reset to zero when the saw disconnects from power.



## Making a Rip Cut

A rip cut is to cut a workpiece lengthwise. When working with materials with directional wood grains, this typically means cutting along the grain.

1. Whenever possible, use the blade guard for making a through cut. Only use the riving knife for non-through cuts.

NOTE: A non-through cut only cuts a slot on the bottom side of a workpiece which makes it impossible to feed through the splitter. Therefore, it is only possible to use the riving knife to prevent kickback.

2. Adjust the fence to set the width of cut. A rip cut must be performed with the fence.
3. Adjust the blade so it protrudes 1/4" or less above the workpiece.

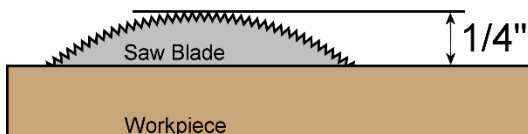

4. Rehearse the cut mentally to plan for the stance and hand placement throughout the entire cut. Prepare to use push stick(s) if feeding a workpiece gets the hands close to the saw blade. The hands should be at least 6" away from the saw blade.

When cutting a big workpiece, make sure it is supported throughout the entire cut and there is enough room to clear the workpiece.

5. When making a narrow cut or cutting smaller workpieces, using additional support such as featherboards can help stabilize the workpiece and prevent kickbacks.

Mount the feather board on the miter slot. Adjust the featherboard so that all fingers of the featherboard are pushing against the edge of the workpiece and the workpiece is firmly pushed against the fence.

Quality featherboards can be purchased at local woodworking supplies stores.

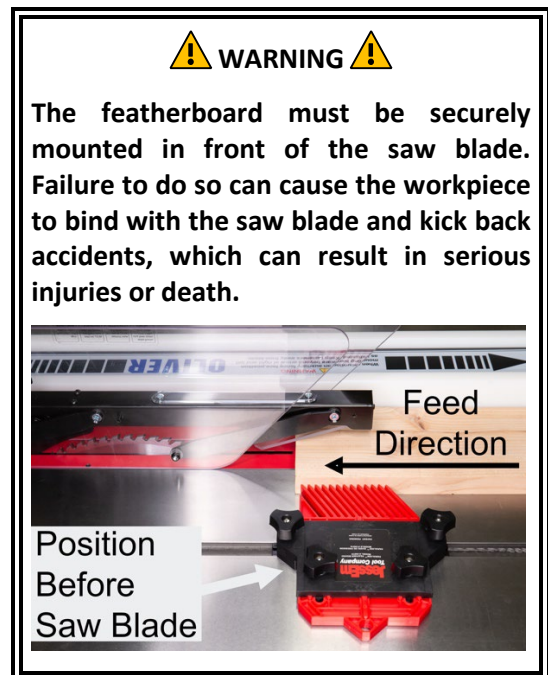

6. Before starting the saw, make sure the blade is not in contact with the workpiece or any guides or guards.
7. Remove pencils, measuring tape, and other items from the table before starting the saw.
8. Turn on the dust collection device and start the saw.
9. Begin the rip cut by holding the workpiece firmly against the fence and the table surface. Feed the workpiece towards the blade. Stay alert and maintain a steady feed rate.



10. When cutting a small workpiece, the hand can get close to the saw blade. In this case, use a push stick to finish the cut.



11. When feeding a workpiece with a push stick, position the push stick close to the blade. Doing so prevents the workpiece from rolling into the blade and kicking back toward the operator.



12. Keep feeding the workpiece until it clears the blade guard or riving knife, then turn off the saw. Wait for the blade to come to a complete stop before retrieving the workpiece.
13. To prevent kickback, never back out a cut while the blade is still spinning. If it is necessary to stop a cut in the middle of the process, stop the saw and wait until the blade comes to a complete stop, then remove the workpiece.

## Making a Cross Cut

A cross cut is to cut across the width of the workpiece. When working with materials with directional wood grains, this typically means cutting across the end grains.

1. Whenever possible, use the blade guard for making a through cut. Only use the riving knife for non-through cuts.

NOTE: A non-through cut only cuts a slot on the bottom side of a workpiece which makes it impossible to feed through the splitter. Therefore, it is only possible to use the riving knife to prevent kickback.

2. Adjust the blade so it protrudes 1/4" or less above the workpiece.

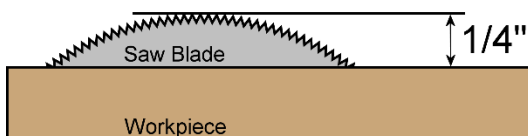

3. Use the provided miter gauge to support the workpiece for the cross-cut.

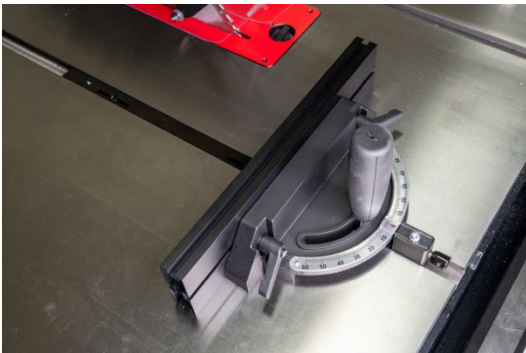

4. Mark the workpiece to set the width of cut.

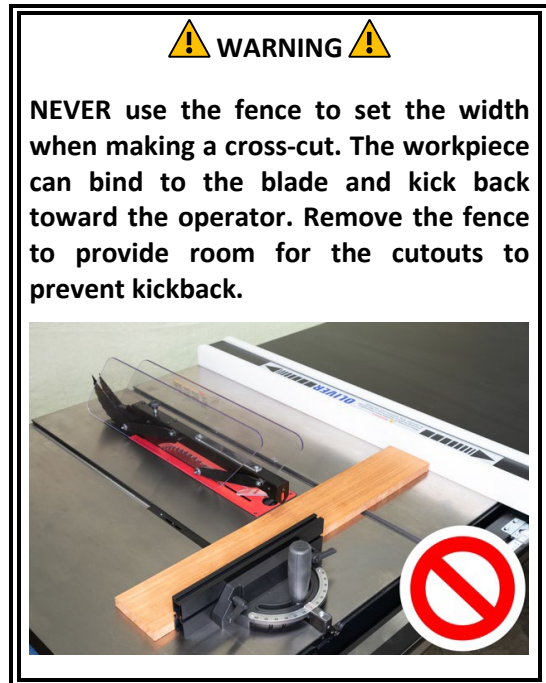

5. Hold the workpiece against the miter gauge, then place the setup near the blade. Adjust the position of the workpiece to line up the cut. When the position is set, pull the setup away from the blade.
6. Before starting the saw, make sure the blade is not in contact with the workpiece or any guides or guards.
7. Remove pencils, measuring tape, and other items from the table before starting the saw.
8. Turn on the dust collection device and start the saw.

9. To begin a cross-cut, hold the workpiece firmly against the miter gauge and the table surface. Feed the workpiece towards the blade. Stay alert and maintain a steady feed rate.



10. When cutting across the end grain, keeping a slower feed rate can reduce tear-outs. However, it may increase the chance of burning the cut edge.
11. Keep feeding the workpiece until it clears the blade guard or riving knife, then turn off the saw. Wait for the blade to come to a complete stop before retrieving the workpiece.
12. Never back out a cut while the blade is still spinning. If it is necessary to stop a cut in the middle of the process, stop the saw and wait until the blade comes to a complete stop, then remove the workpiece.
13. When making multiple cross-cuts, clear the table frequently. Allowing cutoff pieces to accumulate near the saw blade increases the chance of kickback, which can cause serious injuries or death.
14. Some woodworkers use custom-made cross-cut sleds for cross cuts. Always keep hands at least 6" away from the blade when using a cross-cut sled. The sled should be built to keep hands away from the blade.

## Making a Miter Cut

A miter cut is a cross-cut made at a miter angle.

1. The provided miter gauge has a range from 60° left to 60° right. To adjust the miter angle, loosen the handle. Pull out and rotate the quick-adjust pin to set the miter angle. There are five positive stops at -30°, -45°, 0°, 30°, and 45°.

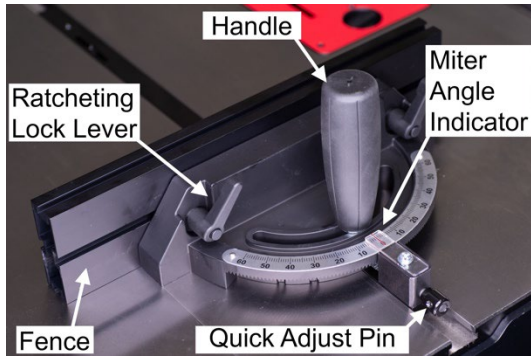

2. Tighten the handle to lock the miter angle after adjustments.
3. The fence of the miter gauge is adjustable so it can slide closer to the blade to better support the workpiece. Loosen both ratcheting lock levers to adjust the distance between the fence and the blade. Make sure the fence does not touch the blade, and then re-secure the fence.
4. When feeding a workpiece at a steep miter angle, the workpiece may get pulled sideways by the resistance of cutting. Make sure the workpiece does not slide by holding it firmly against the miter gauge for the entire cut.

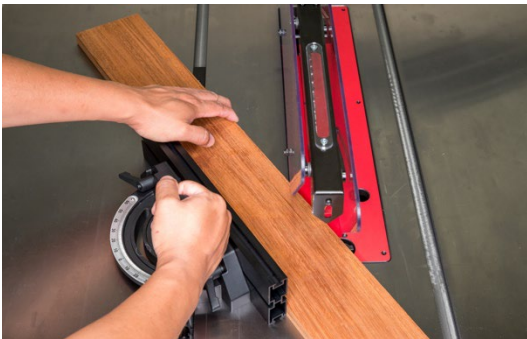

## Making a Bevel Cut

A bevel cut is performed with the blade tilted. Either rip cuts or cross cuts can be made at a beveled angle. When making a beveled cut, make sure the workpiece does not get pinched in between the blade and the table.



**Never use the miter gauge on the left side of the blade when making a bevel cut. The blade guard can block the miter gauge.**



**If using a riving knife instead of a blade guard, the hands will get dangerously close to the blade, as shown in the picture below. If kickback occurs, the hands may get pulled toward the blade. This can result in amputation and serious injuries.**



## Cutting with Dado Set

Dado set is a set of stackable blades that can cut a dado or a rabbet in a single pass. This table saw accepts dado blades up to 12" in diameter, with combined kerf up to 11/16".

### IMPORTANT

**The dado insert for this saw (sold separately) is not designed to make beveled cuts.**

1. Dado and rabbet cuts can only be performed without the riving knife/blade guard. Be extra cautious when feeding the workpiece without an anti-kickback device. Reinstall the blade guard immediately after cutting with the dado set.

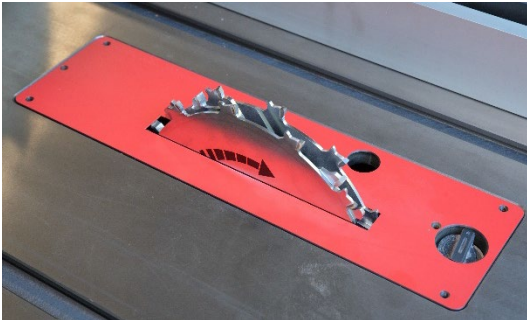

2. Follow the dado set manufacturer's instructions and install the number of blades and shims to set the width of cut. When installing the dado set, make sure the saw blade teeth are distributed as evenly as possible.
3. Never allow the saw blade teeth to stack on each other. That can alter the width of cut and possibly damage the dado set. Also, make sure all the blades are arranged in the correct orientation.

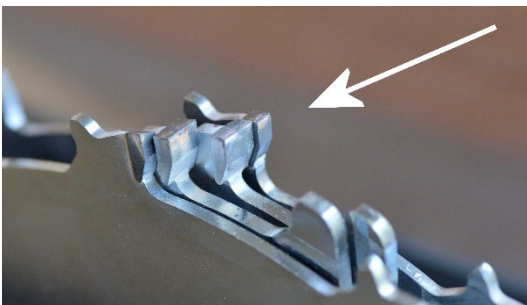

4. Adjust the blade height to set the depth of cut, then lock the blade height handwheel to make sure the depth of cut stays consistent. When making a deep cut, make multiple passes with increasing depth.
5. The dado set is heavier than a standard saw blade. It can take longer for the blades to reach full speed and come to a complete stop. Be patient when working with a dado set.
6. Make test cuts on a scrap piece to verify the width-of-cut and depth-of-cut before cutting the actual workpiece.
7. To reduce chipping and tear-outs for intersecting dado/rabbet cuts, make cuts across the grain first and then along the grain.

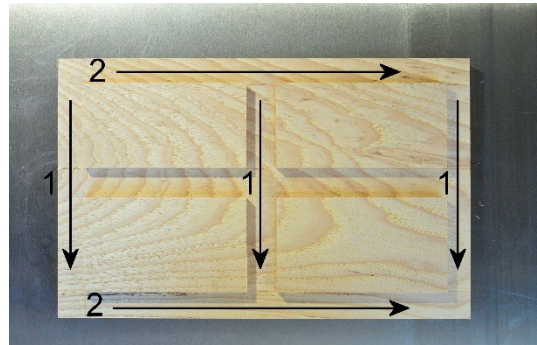

### ! WARNING !

**Never use the dado set to perform a through cut. The dado set is much wider than a standard blade, and it is not designed to perform a through cut. Failure to comply will increase the risk of kickback, which can cause serious injuries or death.**

### ! WARNING !

**The risk of kickback increases when the depth of cut increases. Ensure the workpiece is well supported when making a dado cut. Kickback accidents can result in serious injuries and death.**

### After Using the Table Saw

1. **STOP THE MACHINE** immediately after the work is completed or when the operator leaves the machine for any reason.
2. **WAIT** until the motor comes to a complete stop.
3. **LOWER** the saw blade so it goes below the table.
4. **CLEAN UP** before departure.
5. **LOCK** the power switch by turning the power switch to “OFF” position and removing the key. Doing so prevents the saw from getting started by an untrained person.



# Calibrations and Adjustments

## Blade to Miter Slot Alignment

The blade to miter slot parallelism is calibrated at the factory and should not require further adjustments. The factory tolerance is 0.2mm (approx. 0.008"). Check the blade to miter slot alignment before calibrating the fence.

### IMPORTANT

For the best result, measure the alignment with a dial indicator mounted on a base that can glide along the miter slot. It is also possible to mount the dial indicator on the miter gauge. Make sure there is no play between all components. If a dial indicator is not available, it is possible to measure with a combination square or measuring tape. However, the result can be less accurate.

### CAUTION

This test involves moving the blade. Wear thick leather gloves to prevent injuries from accidental blade contact. Remove the gloves before operating the saw.

1. Disconnect the saw from the power source.
2. Raise the blade to the maximum height and set the blade tilt to 0°
3. Mark the blade to set a reference point near the edge of the saw blade.
4. Move the reference point towards the front of the saw, then position the dial indicator so that its contact point rests on the reference point. Set the dial indicator to zero.



5. Move the reference point towards the rear of the table, then slide the dial indicator to the back so the dial indicator's contact point is again resting on the reference point.

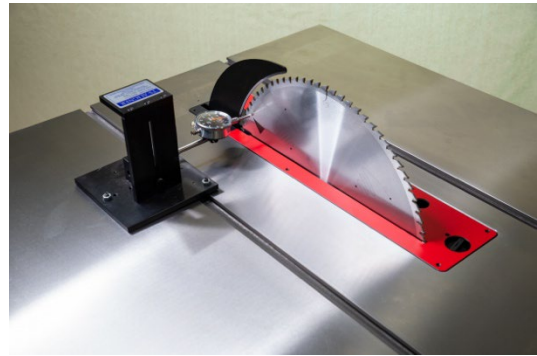

6. Take the measurement. If the offset is greater than 0.2mm or 0.008", rotate the table to align the miter slot to the saw blade.
7. There are four table mounting bolts located at each **corner** of the cabinet. Loosen any three of them with a wrench.



8. Rotate the cast iron table in small increments until the blade aligns with the miter slot.
9. Tighten all table mounting bolts. Repeat steps [4-6] one more time to double check the alignment.

### IMPORTANT

If the table has to be shifted significantly to align the miter slot, the zero clearance table insert will need to be re-slotted or replaced.



## Fence Lock Tightness Adjustment

If the fence cam lock becomes loose:

1. Remove the fence from the rail and rotate both set screws clockwise by 1/6 turn to increase the clamping pressure.



2. Reinstall the fence and recheck the cam lock tightness. Repeat step 1 as needed.
3. Check the fence to miter slot alignment and adjust as needed.

## Fence to Miter Slot Alignment

To prevent kickback and to improve cut quality, the fence must align with the saw blade. When the miter slot aligns with the saw blade, it can be used to align the fence.

1. **Disconnect the saw from the power source.**
2. Mount the dial indicator on a base so it can glide along the miter slot.
3. Position the dial indicator near the front edge of the table.
4. Slide the fence towards the dial indicator so it engages the contact point of the dial indicator. Lock the fence and then set the dial indicator to zero.

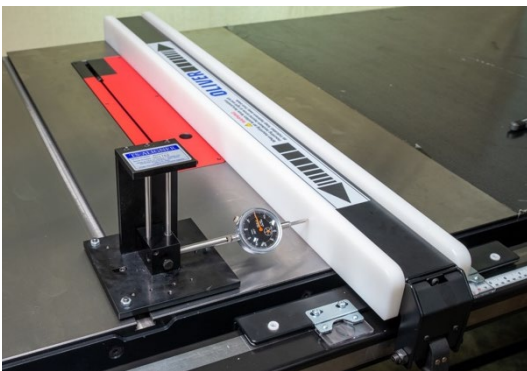

5. Slide the dial indicator to the rear and take the measurement. If the reading of the dial indicator stays the same, the fence is aligned with the miter slot. Otherwise, proceed to the next step for adjustments.

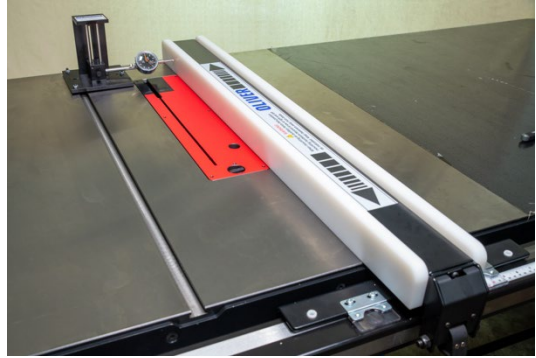

6. Remove the fence from the rail. Adjust the two set screws indicated in the picture in small increments to align the fence.



7. Mount the fence and repeat steps [3-5] to check the alignment. Make further adjustments until the fence is aligned with the miter slot and the fence cam lock pressure is set properly.
8. **NOTE:** Some woodworkers prefer to skew the fence away from the blade to avoid kickback and burning of the cut edge. This is acceptable as long as the offset is less than 1/64". Doing so may impact cut quality.

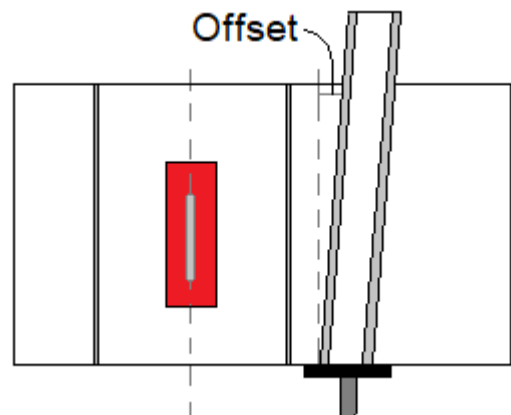

## Fence Squareness Adjustment

1. The fence face should be perpendicular to the cast iron table. Check the squareness of the fence with a machinist square.



2. To adjust the squareness of the fence, adjust the two nylon set screws on the fence bracket until the fence face is perpendicular to the table.

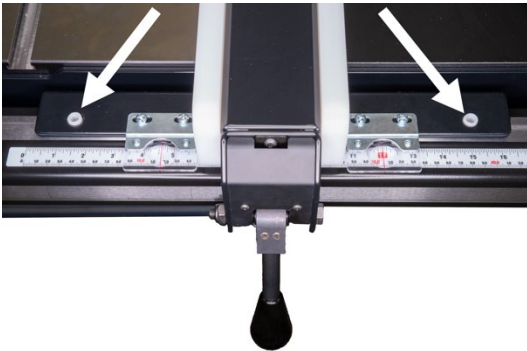

3. After the adjustment, check the height and levelness of the fence. Make sure the fence is elevated approximately 1/16" above the table.

## Fence Height Adjustment

1. There should be a 1/16" gap between the fence face and the table. The gap allows the fence to slide freely and not scratch the table. If the gap is too big, or if the fence is scratching the table, or if the fence is not level from front to rear, adjustment is needed.
2. To adjust the height of the fence in the front, make the same amount of adjustments on both nylon set screws.

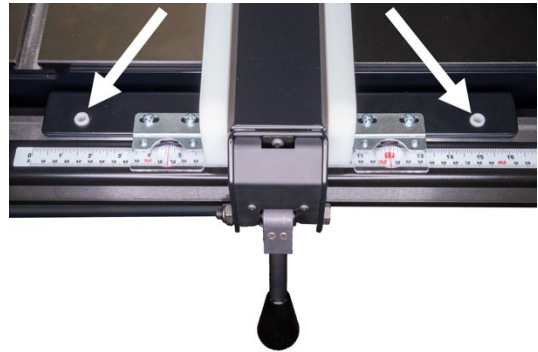

3. The fence in the rear is supported by a fixed-height glide pad. Replace the glide pad when it is worn or damaged.

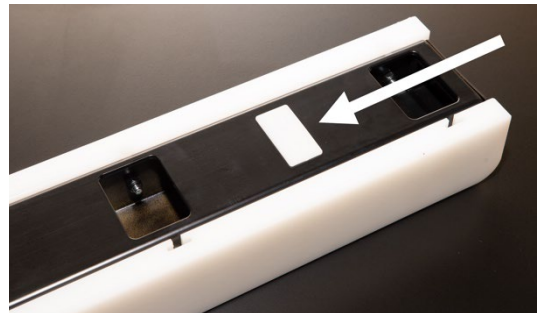

## Fence Scale Adjustment

The fence scale should be adjusted if the width-of-cut it indicates does not match the actual cut width.

1. Prepare a piece of scrap plywood with a straight edge for ripping. The scrap piece should be approximately 13" wide and 24" long.
2. Reposition the fence to set the width-of-cut to 12".
3. Follow the safety guidelines and the procedures in "Making a Rip Cut" on page 41 to make the rip cut.
4. Measure the new width of the scrap piece.
5. To adjust the indicator, loosen the screws that hold the indicator in place, reposition the indicator, and then retighten the screws.

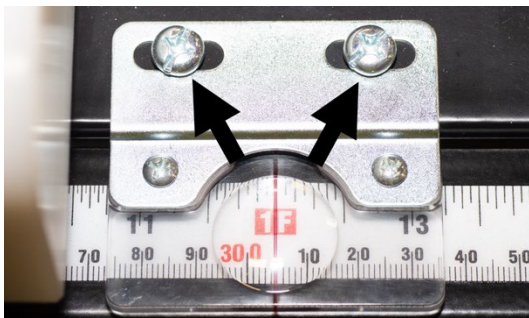

## Miter Gauge Angle Indicator Adjustment

If the miter angle indicator has shifted and does not indicate the correct angle, it can be adjusted.

1. **Disconnect the saw from the power source.**
2. Use a square to set the miter angle to 90° against the blade. Tighten the handle to lock the miter gauge.

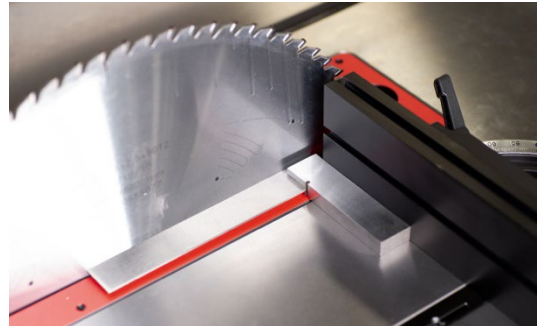

3. Loosen the screw that holds the indicator in place.

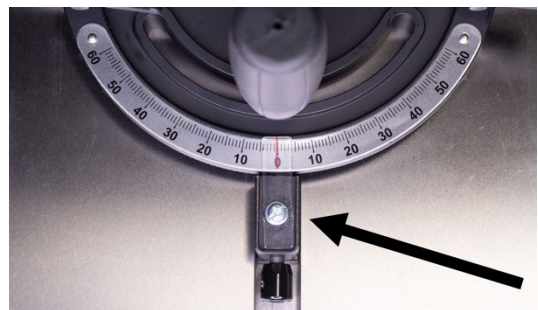

4. Adjust the indicator and tighten the mounting screw.

## Blade Tilt Angle Pointer Adjustment

The blade tilt angle pointer was calibrated at the factory and should not need further adjustments. If the pointer has shifted, it can be adjusted.

1. **Disconnect the saw from the power source.**
2. Set the blade angle to 90° with a digital protractor or a machinist square.

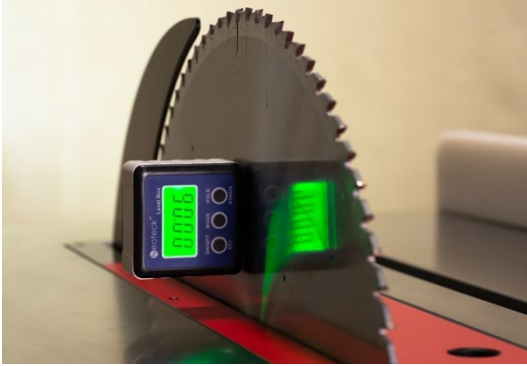

3. Locate the screw that holds the pointer in place. It is behind the blade height handwheel.

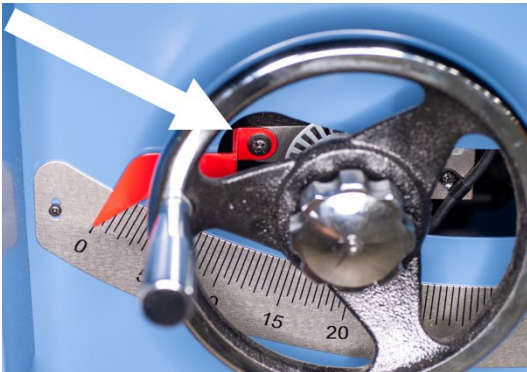

4. Loosen the screw, adjust the pointer, then retighten the screw.
5. This is also a good time to reset the reading of the blade tilt angle value on the digital readout. Long press the “Set 0” button to zero the reading.

## Blade Angle Positive Stops Adjustments

There are two positive stops for setting the blade tilt angle at 0° and 45°. These positive stops are calibrated at the factory and should not require further adjustments. Please follow these steps in case adjustments are needed.

1. **Disconnect the saw from the power source.**
2. The 0° positive stop bolt is located behind the motor access panel. Remove the motor access panel.



3. The 0° positive stop bolt can be found on top of the gear block (#77 in the parts diagram), and it's secured by the jam nut.

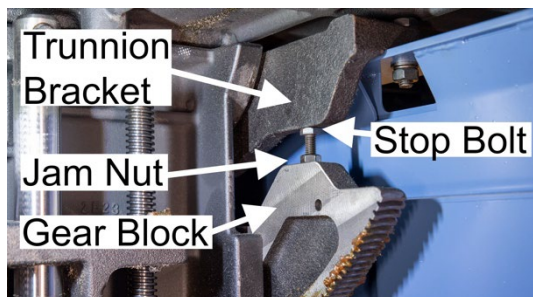

4. To adjust the stop bolt, adjust the blade angle so the stop bolt is not in contact with the trunnion bracket (#84 in the parts diagram), then loosen the jam nut. Adjust the stop bolt until it stops the trunnion when the blade is perpendicular to the table, then lock the stop bolt with the jam nut.

5. The 45° positive stop bolt is located behind the dust shroud access panel. Open the dust shroud access panel.

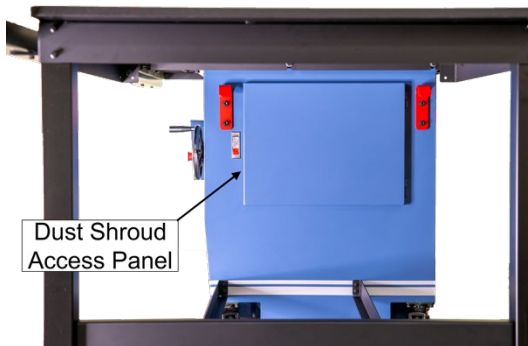

6. The 45° positive stop bolt can be found on top of the gear block (#77 in the parts diagram), and it's secured by the jam nut.

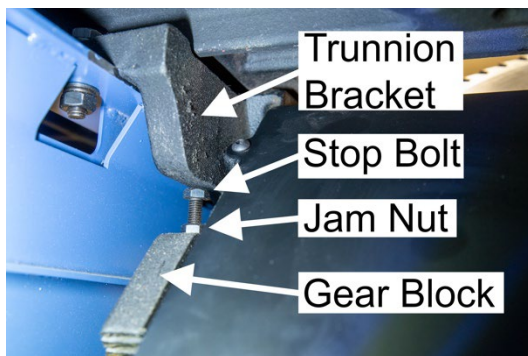

7. To adjust the stop bolt, adjust the blade angle so the stop bolt is not in contact with the trunnion bracket (#84 in the parts diagram), then loosen the jam nut. Adjust the stop bolt until it stops the trunnion when the blade tilt angle is 45°, then lock the stop bolt with the jam nut.

## Spreader/Riving Knife Mounting Bracket Alignment Adjustment

The spreader/riving knife alignment was calibrated in the factory and should not require further adjustments. If a riving knife or spreader is not aligned with the blade, make sure it is not bent. Follow the steps below if the mounting bracket needs an adjustment.

1. **Disconnect the saw from the power source.**
2. Wear thick leather gloves for this procedure, as the calibration work will be done next to the saw blade.



3. Remove the table insert.
4. Raise the saw blade to maximum height.
5. Use the arbor wrench to loosen the mounting nut and remove the spreader/riving knife.

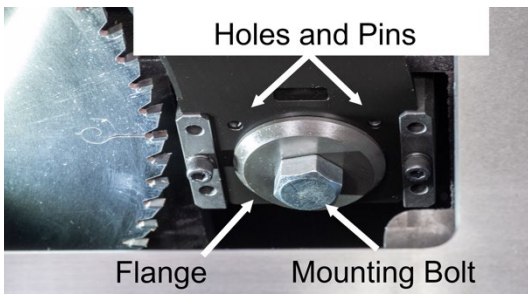

6. Loosen up the two hex cap screws on the bracket.

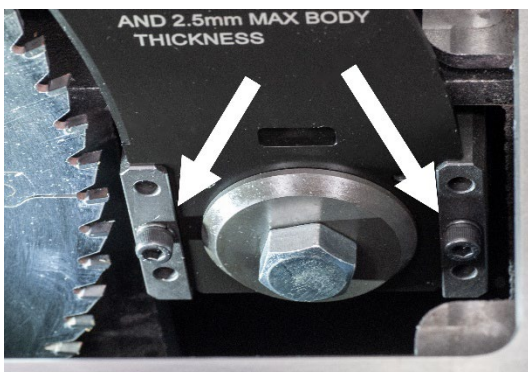

7. Adjusting the top/bottom pair of set screws will cause the riving knife to roll left or right along the horizontal axis. Adjusting the left/right pair of set screws will cause the riving knife to rotate along the vertical axis. Make the same amount of small adjustments on the pair of set screws.

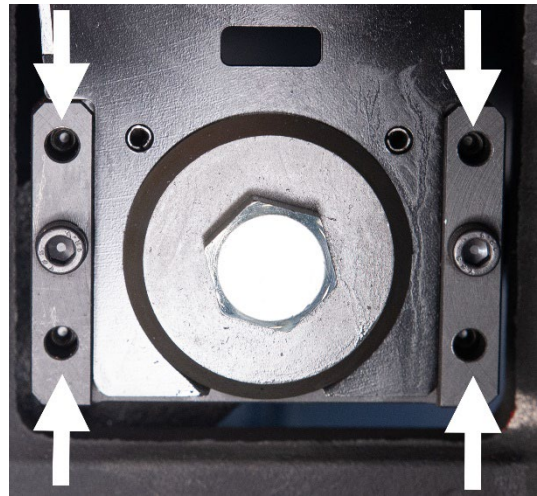

8. Tighten the cap screws and reinstall the riving knife to test the adjustment.
9. Repeat steps [5-8] until the riving knife aligns with the blade and stays within the "alignment zone".

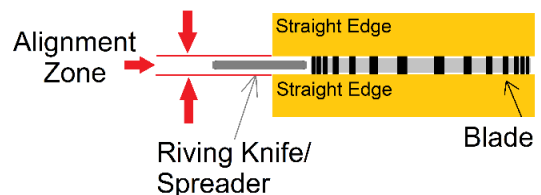

10. Reinstall the table insert and remove gloves before cutting with the table saw.

# Maintenance

Routine maintenance keeps your table saw in optimal condition. Please follow the maintenance schedule below and use the maintenance record worksheet attached to document all tasks completed.

**NOTICE:** Maintenance schedule may vary for individual users due to different situations and safety requirements.

Task	Frequency
Inspect the power switch, cord, and plug for signs of failure.	Every day before any operation begins.
Inspect the saw blade for signs of damage. Replace damaged/dull blades.	Every day before any operation begins.
Clean cast iron table and miter slots, then apply rust protectant.	Weekly
Remove dust accumulated inside the cabinet.	Monthly
Clean trunnion slides, worm gear, and elevation rails. Lubricate with self-cleaning dry lube.	Every 6-12 months.
Inspect the anti-kickback pawls of the blade guard. Resharpen as needed.	Every 6-12 months.



**WARNING** Disconnect the machine from the power source before performing any maintenance work. After servicing the table saw, remove all tools before restarting the machine. Failure to comply can cause serious injury!

## Dust Accumulation Removal

Inspect the cabinet and dust shroud monthly and remove dust accumulation as needed.

1. Disconnect the saw from the power source.
2. Open the dust shroud access panel.
3. Remove the thumb screw that locks the dust shroud door.

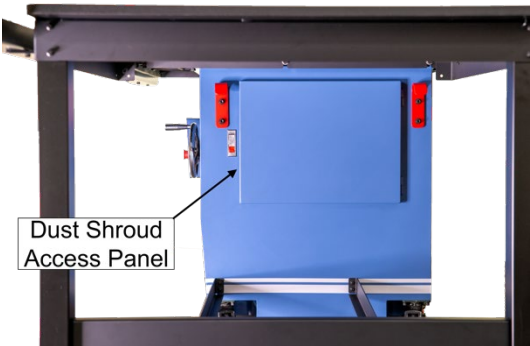

4. The dust shroud captures most of the dust produced. If dust accumulates inside the dust shroud, remove the dust accumulation with a vacuum.
5. Lock the dust shroud door and the dust shroud access door before starting the saw.

## Trunnion Components Cleaning and Lubrication

Clean and lubricate the trunnion slides, worm gear, and elevation rails every 6-12 months or when it becomes difficult to adjust the saw blade positions.

1. **Disconnect the saw from the power source.**
2. Remove the motor access panel.



3. Remove the table insert.



4. Use a vacuum to remove as much dust inside the cabinet as possible.
5. Remove gum-up grease on the front and rear trunnion slides:



6. Remove gum-up grease on the blade elevation gears, blade tilt gears, and elevation rails:

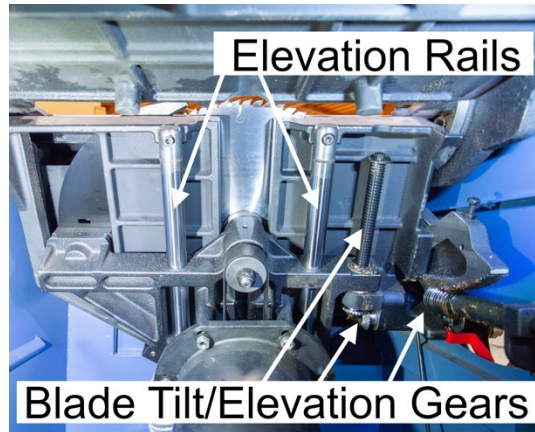

7. Use mineral spirit to remove build-ups that are difficult to remove.
8. Relubricate the components with self-cleaning dry lube, paste wax, or lithium grease.



## Belt Tension Adjustment

Belt tension was calibrated at the factory, and it should not require adjustments initially. After a long period of use, the poly-v belt may stretch and slip on the pulleys. When that happens, the belt needs to be tightened.

1. Disconnect the saw from the power source.
2. Remove the motor access panel.



3. Check the belt tension by pinching the belt together gently. The belt should deflect by 1/8" - 1/4".

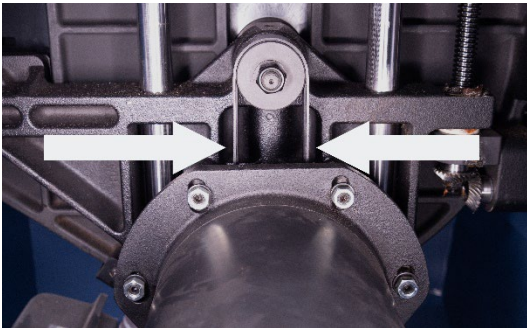

4. If the belt is cracking or showing any sign of damage, follow the instructions in "Belt Replacement" in the next section instead.

5. If the belt is too loose, slightly loosen the four motor mounting nuts so the motor can be lowered by gravity. DO NOT remove the nuts. If needed, use a rubber mallet to gently tap on the motor mounting plate to lower the motor and increase belt tension.



6. Tighten all four mounting nuts to secure the motor.
7. Reinstall the motor access panel to complete the process.

### **IMPORTANT**

Do not over tension the belt, as it can accelerate wear and tear of the belt and the bearings.

## Belt Replacement

1. **Disconnect the saw from the power source.**
2. Remove the motor access panel.



3. Slightly loosen the four motor mounting nuts so the motor can be temporarily raised to the highest position. Retighten the nuts.

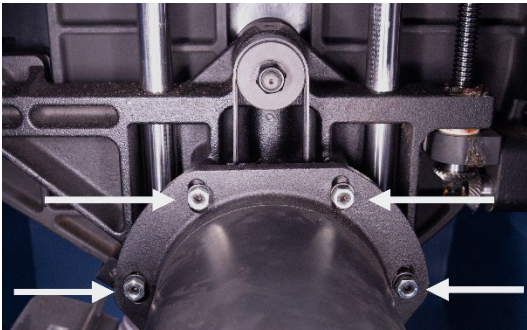

4. Remove the belt by walking the belt off the arbor pulley and then sliding the belt through the gap between the motor pulley and the elevation bracket (#32 in the parts diagram).
5. Install the new belt. First, slide the belt through the gap between the motor pulley and the elevation bracket, then walk the belt and make sure it sits correctly on the motor pulley and arbor pulley.
6. Loosen the motor mounting nuts to tighten the belt, then retighten the nuts to secure the motor.
7. Reinstall the motor access panel to complete the process.

### **IMPORTANT**

Do not over tighten the belt, as it can accelerate wear and tear of the belt and the bearings.

## Table Insert Setup

1. Install the table insert and adjust the six set screws until the insert is flush with the table, then rotate the lock knob clockwise to secure the insert.



2. **NOTE:** The zero-clearance table inserts must be cut before use. Please make sure the saw is calibrated and the desired blade is properly installed before cutting the insert.
3. Before cutting the slot of the table insert, make sure the insert is locked securely on the table and the blade is lowered completely.



4. Put on protective gear.

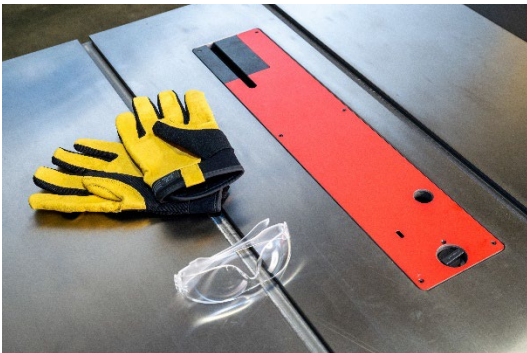

5. Connect the saw to a power source.

6. Set the blade angle to 0°, so the blade is perpendicular to the table.

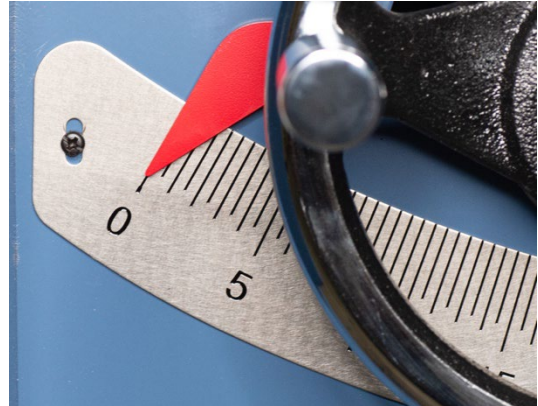

7. Clamp a piece of straight and thick wood board on top of the insert where the slot will be cut. Doing so ensures the insert stays in place when it is cut and reduces the amount of dust released.

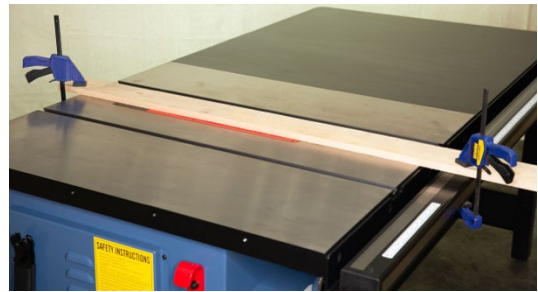

8. Turn on the dust collection system.
9. Turn on the saw and slowly raise the blade to its maximum height.
10. Turn off the saw. Lower the blade completely and remove the supporting board and clamps.

11. To minimize tear-outs, the zero clearance table inserts should be cut for a specific blade tilt angle. If the insert needs to be used for the entire range of blade tilt, set the blade angle to 45°, then repeat steps 7-10 with a new board supporting the table insert.



**Only the regular zero clearance table insert (Part# 4065.A003) can be slotted multiple times at different blade tilt angles.**

**The dado insert can only be slotted when the dado blades are perpendicular to the table. Attempting to slot the dado insert at a beveled angle can destroy the dado insert and may cause severe injuries.**



**Slotting a homemade table insert at different angles may create debris that is large enough to get caught in between the blade and the dust shroud. The debris can become a high-speed projectile when struck by the blade. This hazardous situation can cause serious injury to the operator and damage the table saw.**

12. Disconnect the table saw from power after setting up the table insert.

# Troubleshooting

## Mechanical / Electrical Issues

Problem	Possible Cause	Solution
<b>Machine does not start.</b>	Not connected to a power source.	Make sure the machine is plugged in. Check the electrical panel for a tripped circuit breaker or a blown fuse. Ensure all electrical connections have good contacts.
	The saw was overloaded, and thermal protection was triggered.	Wait for at least 1 minute for the motor to cool down and the thermal relay to reset automatically before restarting the saw.
	Low voltage/current.	Have a licensed electrician check/repair the power circuit.
	Power switch is locked.	Use the provided key to unlock the saw. Turn the key to "ON" position.
	Faulty switch/motor/capacitor.	Contact customer service for further assistance.
<b>Machine stalls or does not come up to speed.</b>	Extension cord is too light or too long.	Use a shorter / heavier cord that meets this machine's electrical requirements.
	Feeding rate is too high.	Reduce feed rate.
	Dull blade or wrong blade for the cut.	Use a sharp, clean blade that is designed for the type of cut.
	Feeding stock with the blade installed backwards.	Reinstall the blade the correct way.
	Ripping crooked stock.	Straighten the fence-facing edge of a workpiece before the rip cut. Avoid ripping unstable stock.
	Stock binding between the blade and the fence.	Ensure both the saw blade and the fence align with the miter slot. Adjust alignment as needed.
	Belt slipping	Clean belt and pulleys. Check/adjust belt tension and make sure the belt is seated properly.
	Motor is not wired properly for the operating voltage.	Use the wiring diagram to properly wire up the motor.
Motor/capacitor issue.	Contact customer service for further assistance.	

Problem	Possible Cause	Solution
<b>Machine stopped during the operation.</b>	Tripped circuit breaker or blown fuse.	Reconnect circuit. Reduce feed rate.
	Saw was overloaded, and thermal protection was triggered.	Wait for at least 1 minute for the motor to cool down and the thermal relay to reset automatically before restarting the saw.
<b>Machine vibrates excessively.</b>	Machine stands on uneven floor.	Reposition the machine on a flat, level surface. Adjust the leveling feet to keep the machine stable.
	Unbalanced saw blade	Inspect the saw blade and replace damaged or warped saw blade.
	Blade was mounted improperly.	Mount the saw blade with the right amount of torque. Do not overtighten the arbor nut.
	Worn/loose belt	Check/adjust belt tension. Replace worn/broken belt.
	Improper motor/component mounting.	Check, adjust, and tighten motor/component mounting.
	Motor/arbor bearing issue.	Contact customer service for further assistance.
<b>Blade misaligned with the miter slot.</b>	Warped blade.	Replace blade.
	Table misaligned.	Align the miter slot to the blade.
<b>Blade elevation/tilt handwheel binds or is difficult to turn.</b>	Lock knob engaged.	Loosen the lock knob.
	Sawdust/debris build-up inside the cabinet.	Remove dust and debris inside the cabinet. Use dry lube to lubricate the elevation/trunnion gears and slides.
<b>Fence does not clamp securely on the rail.</b>	Nylon pads between the fence and the rails are worn.	Tighten both fence alignment screws and readjust fence alignment. Replace nylon pads if they are too worn.
<b>Fence does not glide smoothly on the rails.</b>	Fence alignment screws were not adjusted properly.	Loosen the screws and readjust fence alignment.
	Rails are dirty.	Clean the rails and the nylon pads that shim between the rails and the fence.
	Worn glide pad and/or nylon screws.	Replace glide pad and/or nylon screws.
<b>The belt squeaks momentarily when the motor starts.</b>	Loose belt.	If the belt only squeaks for a fraction of a second when the motor starts, it is normal. If the belt keeps squeaking, tighten the belt.

## Operation Issues

Problem	Possible Cause	Solution
<b>Kickback.</b>	Not using any anti-kickback devices.	Whenever possible, use the blade guard or riving knife when cutting with a table saw.
	Making cross cuts with a miter gauge and using a fence to set the length of the cut.	Remove the fence when using a miter gauge for cross-cuts.
	Fence is not aligned with the blade.	Adjust fence alignment.
	Riving knife/spreader is not aligned with the blade.	Adjust riving knife/spreader alignment.
	Cutting warped/unstable stock.	A warped workpiece should be flattened and have at least one edge straightened before being cut with a table saw. A slightly cupped board should have the cupped side facing down to improve stability when feeding.
	Improper feeding techniques.	Never rotate the workpiece into the back side of the blade when feeding.
<b>Saw dust escape and blow toward the operator.</b>	Dust collection system is not operational or underpowered.	Ensure the dust collection system is turned on and has significant suction. Unclog dust shroud and hose, and seal leaks in the dust collection system.
	Blade guard not installed.	Install the blade guard.
	Dust shroud is clogged.	Remove dust accumulated inside the dust shroud.
<b>Workpiece catches the table insert when feeding.</b>	Table insert is not flush with the table.	Adjust the height of the table insert so all edges are flush with the table.
<b>Incorrect reading on the digital readout.</b>	The digital readout was not zeroed.	Re-zero the digital readout for blade height while the blade dips right below the table.
		Re-zero the blade tilt reading with a machinist's square.

## Quality-Related Issues

Problem	Possible Cause	Solution
<b>Stock burns.</b>	Stock binds with the blade.	Adjust alignment between the miter slot, blade, fence, and riving knife/spreader.
	Feeding motion paused during operation.	Maintain feeding speed while cutting the entire length of the stock.
	Feeding speed is too low.	Increase feeding speed and cut with a sharp, clean blade.
	Dull blade or wrong blade for the cut.	Use a sharp, clean blade that is designed for the type of cut.
	Warped/unstable stock	Straighten the fence-facing edge of a workpiece before the rip cut. Avoid ripping unstable stock.
<b>Unexpected width of cut.</b>	Reading the wrong scale pointer on the fence.	Use the scale pointer on the right when ripping on the right hand side of the blade, and vice versa.
	Using a saw blade with different kerf.	Adjust the scale pointer.
	The fence scale pointer is not adjusted.	Adjust the scale pointer.
<b>The edge of a rip cut is not squared.</b>	Incorrect blade tilt angle.	Adjust blade tilt angle.
	Blade tilt angle pointer is misaligned.	Adjust blade tilt angle pointer.
	Positive stop bolt out of adjustment.	Adjust positive stop bolt.
	Fence is not vertically parallel to the blade.	Adjust fence squareness.
<b>Saw marks on the cut edge</b>	Warped/dirty/worn blade.	Use a balanced, clean, and sharp blade for cutting.
	Fence is not aligned with the blade.	Adjust fence alignment with the blade.
	Miter slot is not aligned with the blade.	Adjust miter slot alignment with the blade.
<b>Cut edge splintering when making cross cuts.</b>	Dull blade	Replace the dull/dirty blade with a clean, sharp blade.
	Saw blade has too few teeth, or the feed rate is too high.	Use a cross-cut saw blade and/or reduce feed rate.



# Wiring Diagrams

For Stock # 4065.002 (230V/460V, 3Ph)

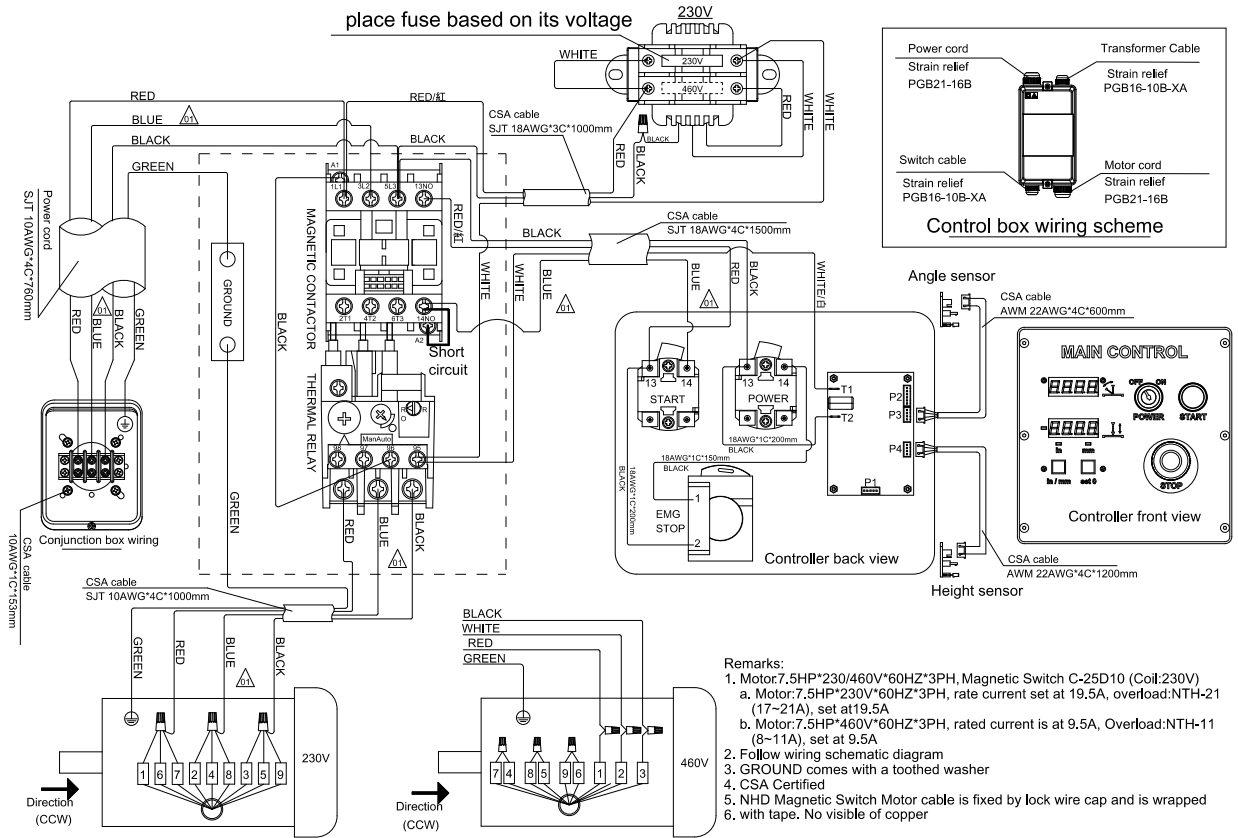

**DANGER** Deenergize the electrical circuit before touching any enclosed, electrified parts. Touching an electrified part **WILL** result in serious personal injury or death.

**WARNING** Faulty electrical work can cause electrocution and is a fire hazard. All electrical work must be completed by a licensed electrician and must meet the local electrical code in your area, or the warranty is void.

For Stock # 4065.003 (230V/460V, 3Ph)

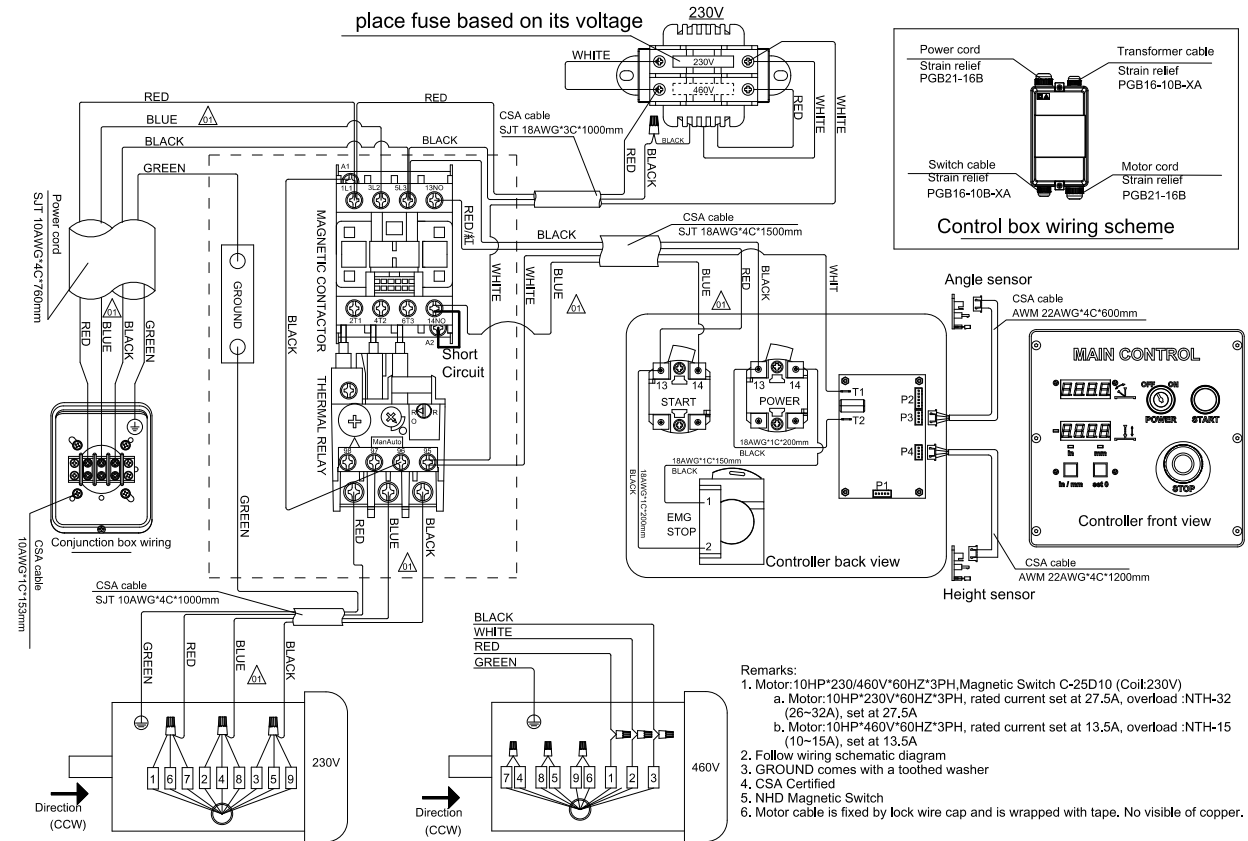

**⚠ DANGER**

**Deenergize the electrical circuit before touching any enclosed, electrified parts. Touching an electrified part WILL result in serious personal injury or death.**

**⚠ WARNING**

**Faulty electrical work can cause electrocution and is a fire hazard. All electrical work must be completed by a licensed electrician and must meet the local electrical code in your area, or the warranty is void.**

# Parts List

## Table and Blade Guard

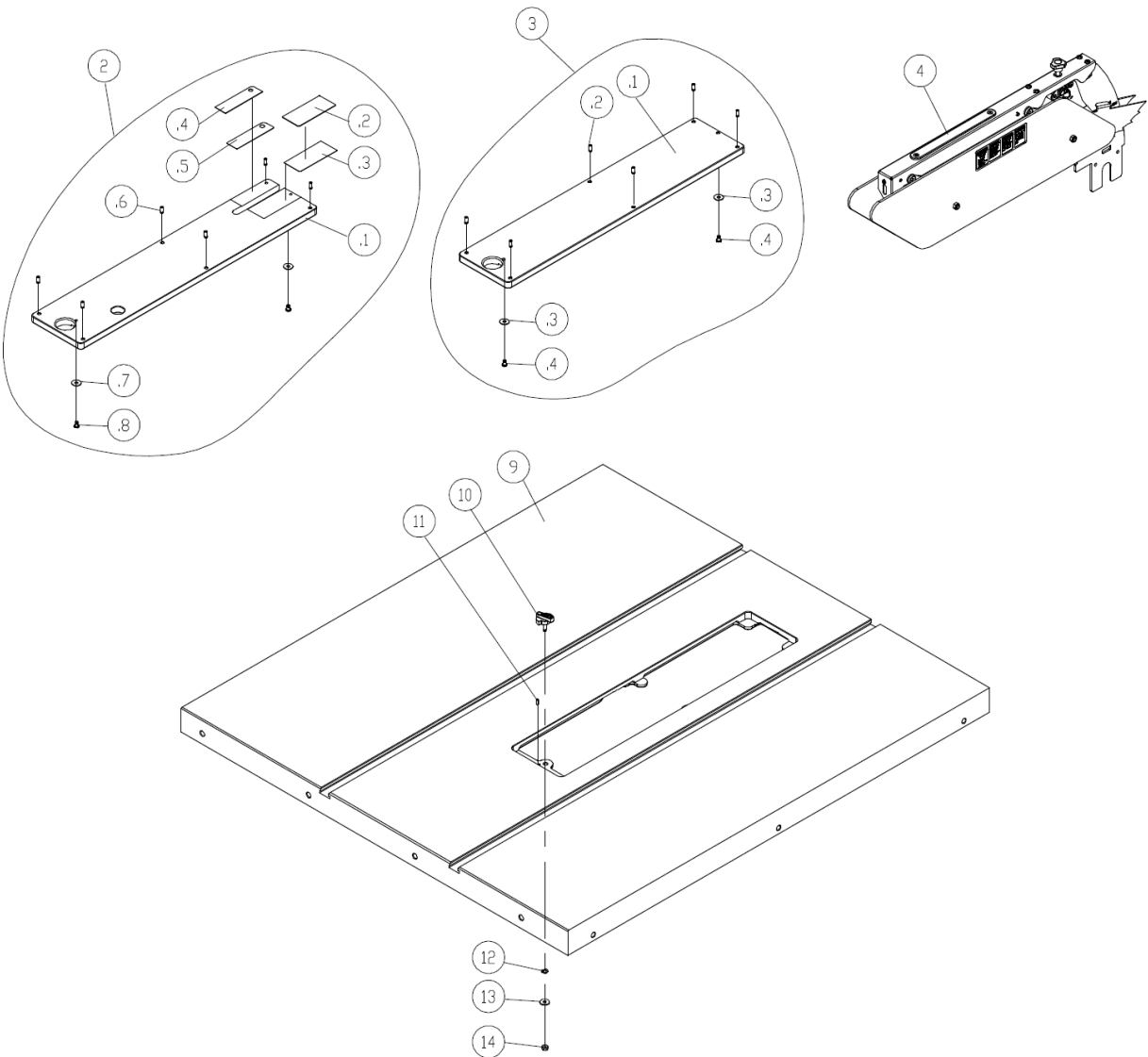

# Cabinet

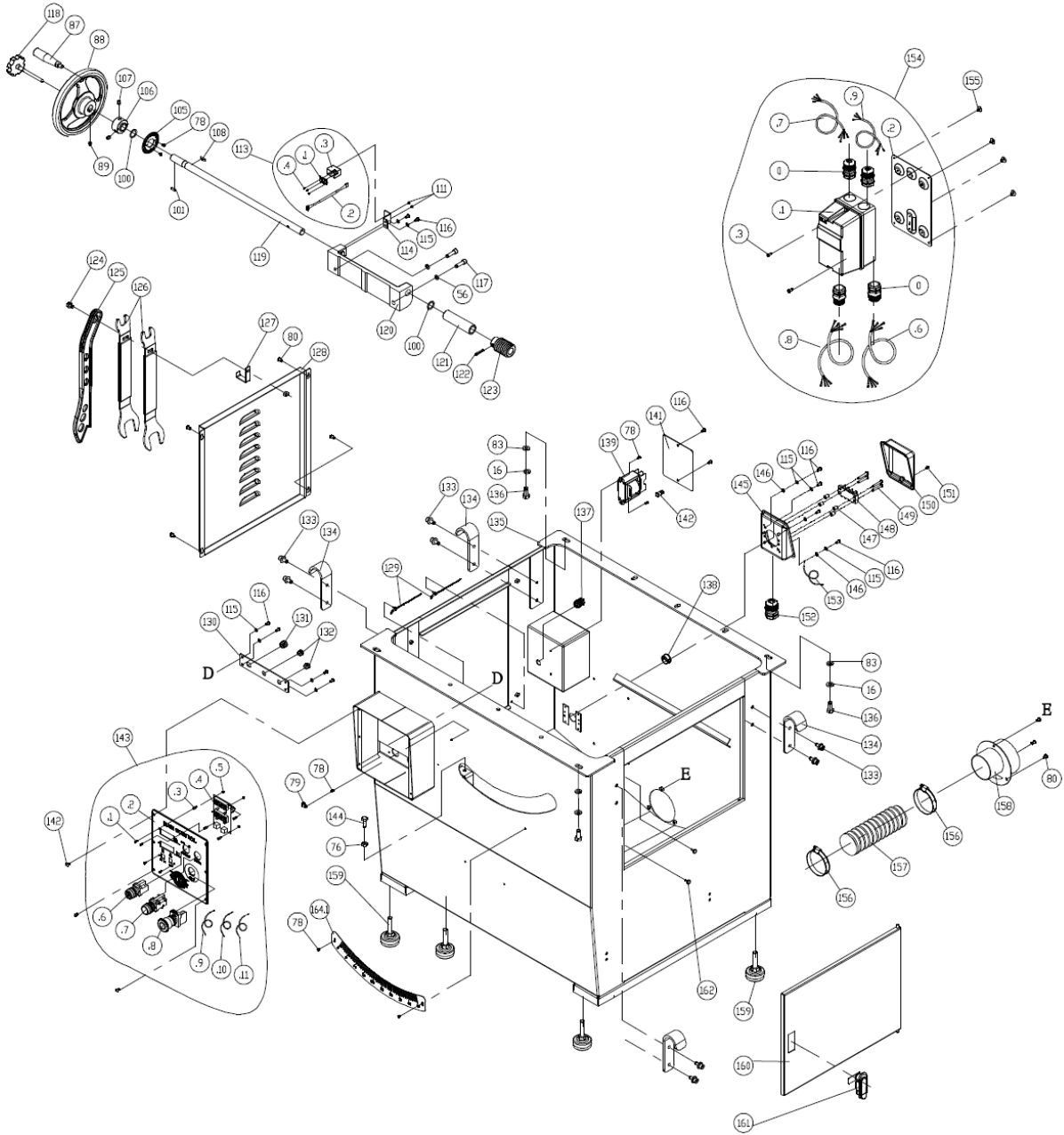

# Motor and Blade Lift Assembly

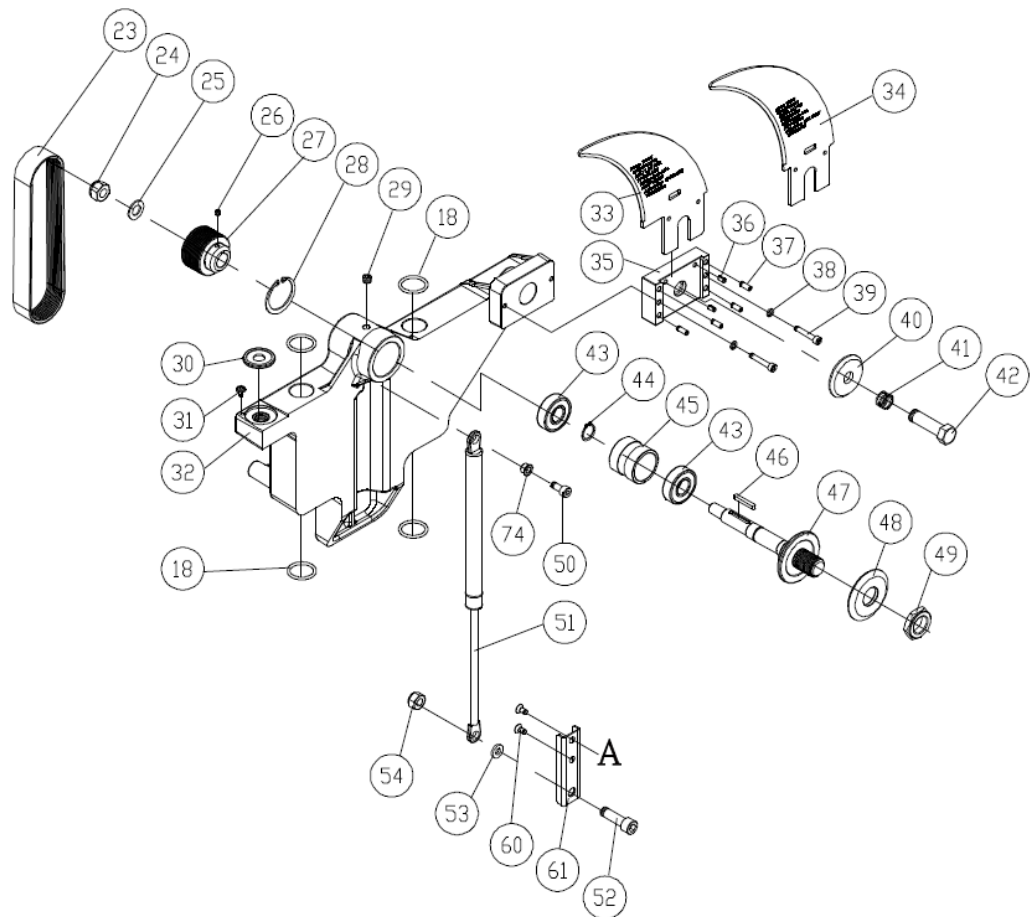
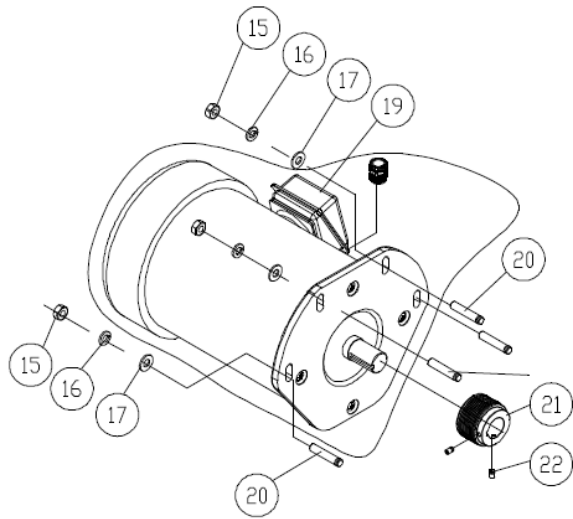

# Trunnion Assembly

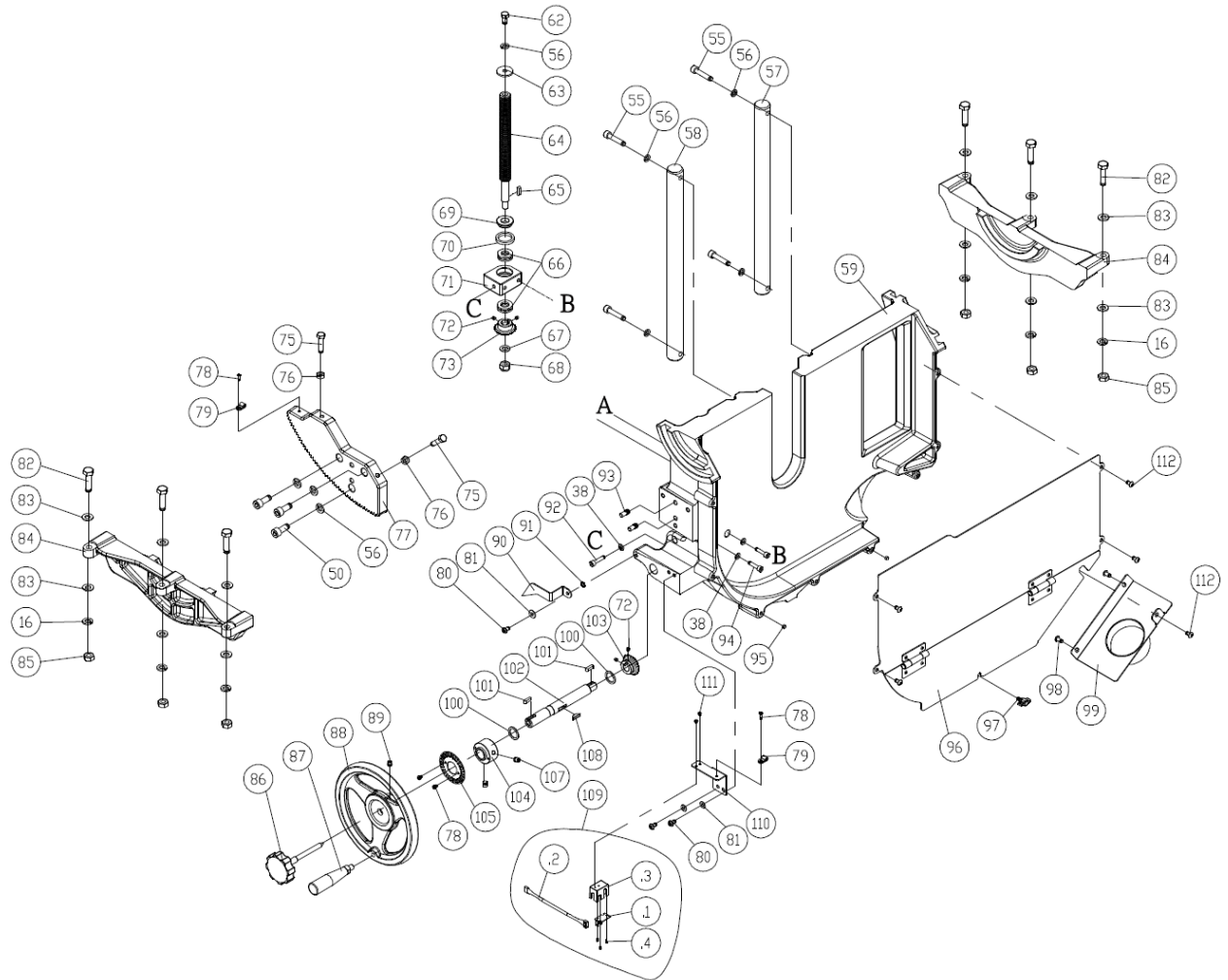

Rails

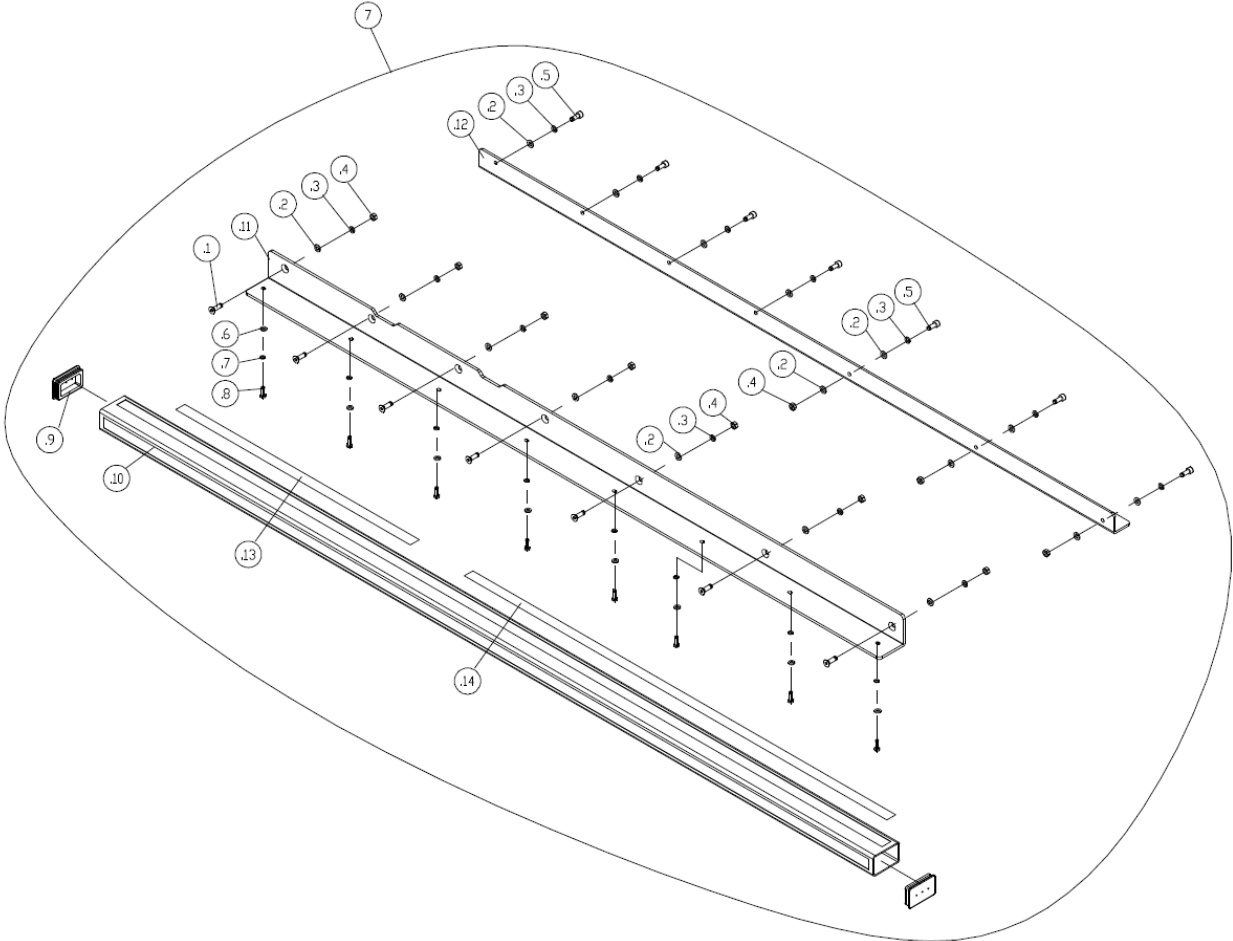

# Extension Table

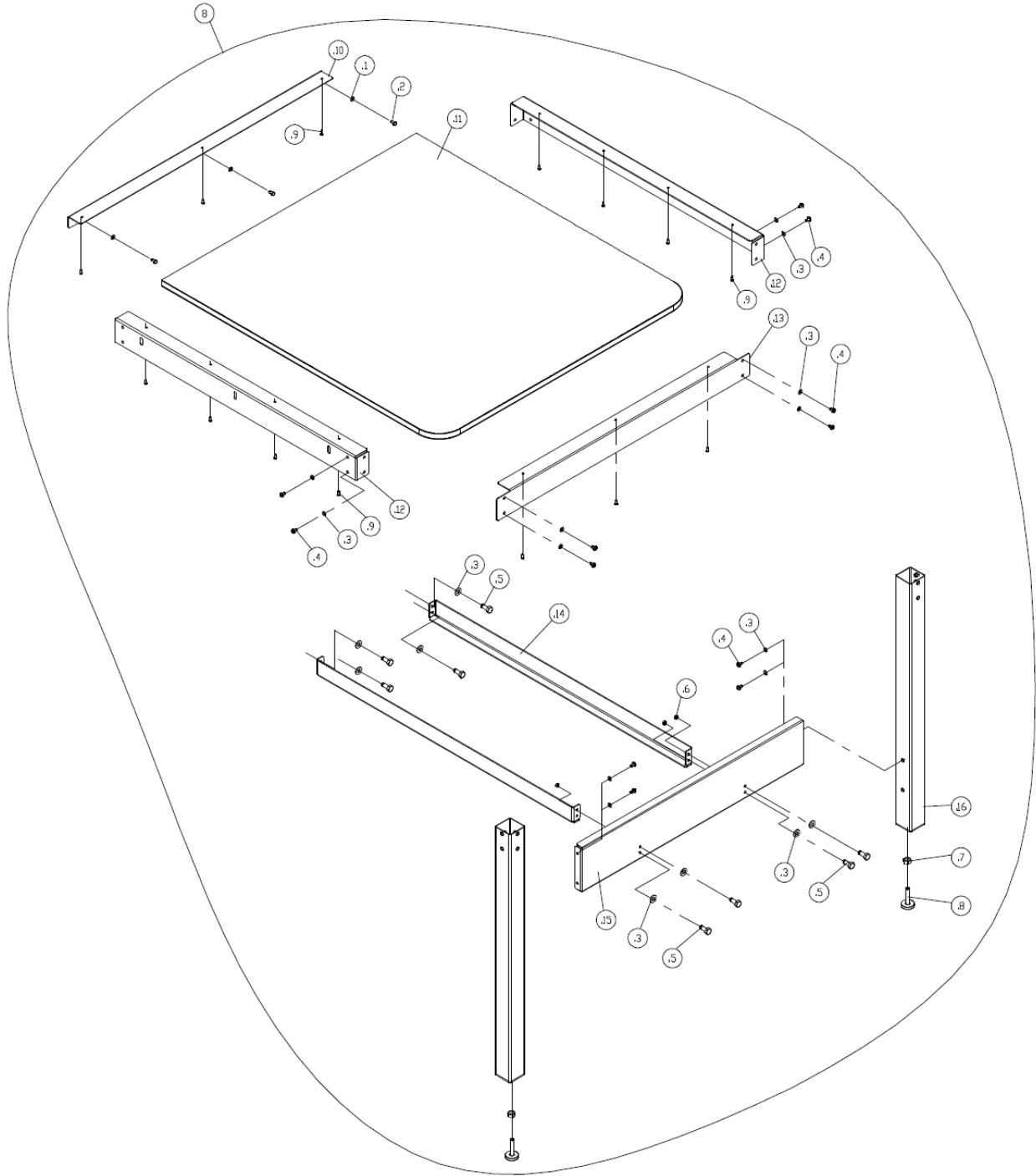



# Rip Fence Assembly

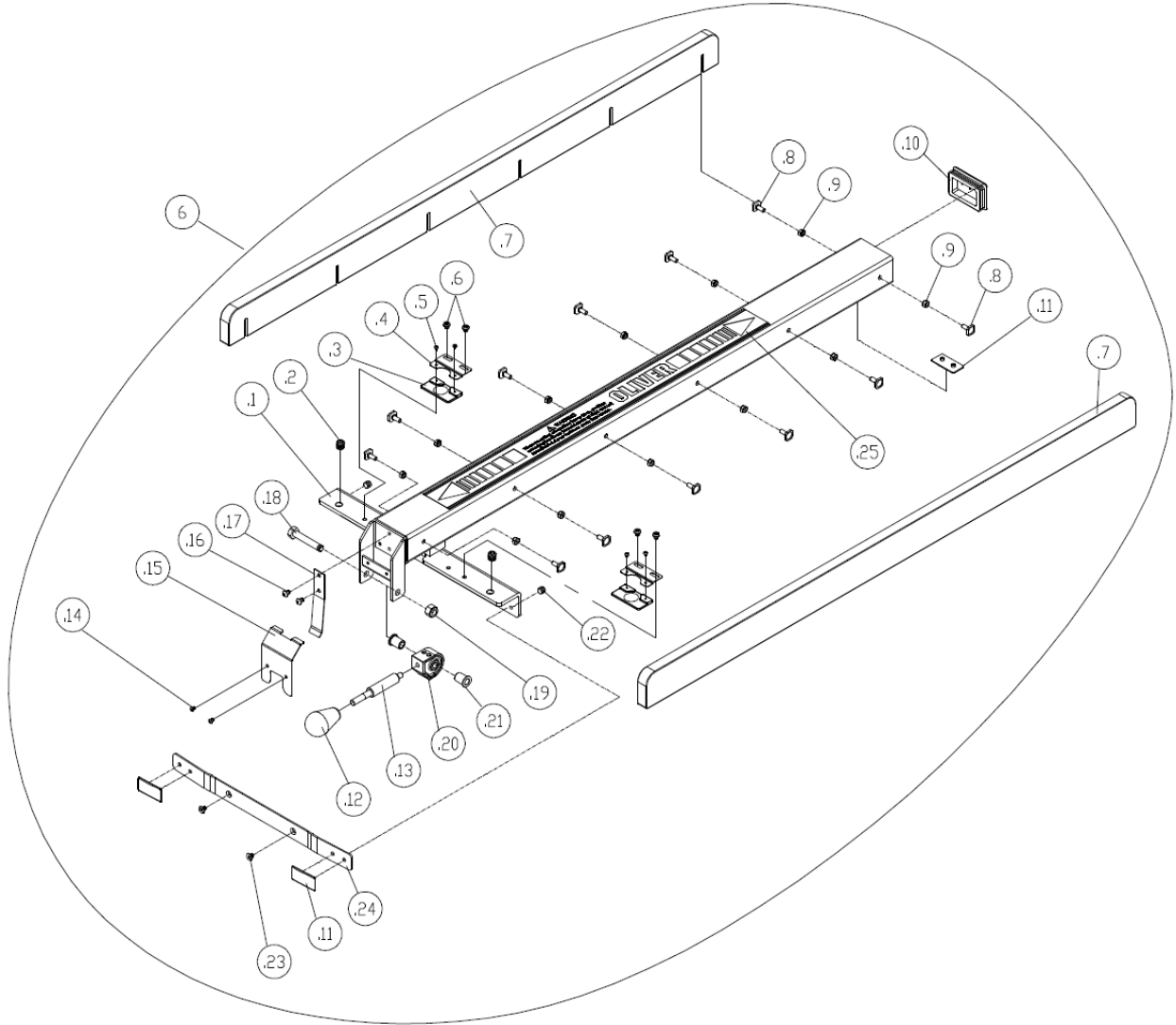

# Miter Gauge

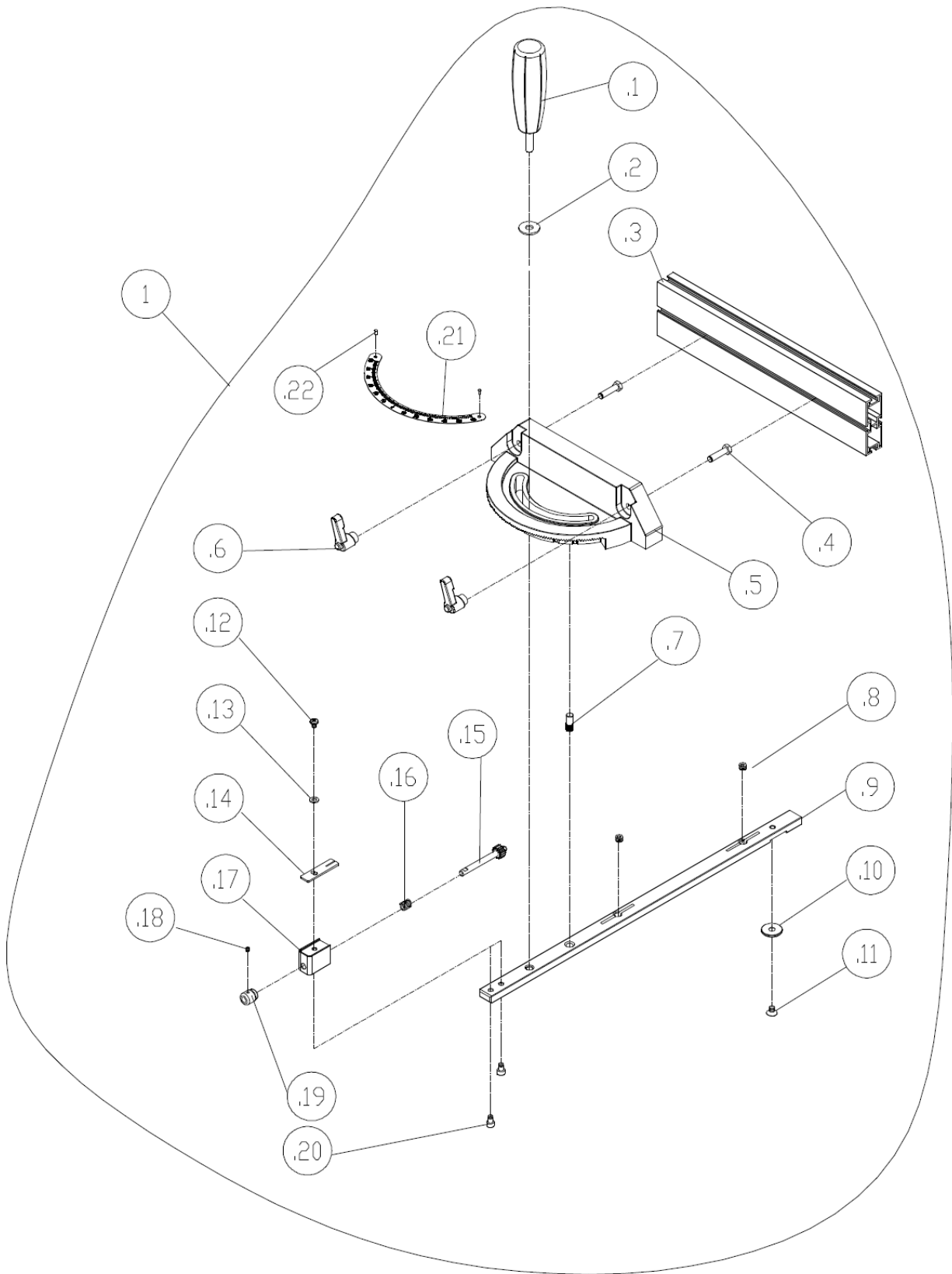

Index	Part Number	Descriptions	QTY
<b>1</b>	924562-000	Miter Gauge Assembly	1
<b>1.1</b>	230191-000	Miter Gauge Handle	1
<b>1.10</b>	130380-903	Retaining Disc	1
<b>1.11</b>	000403-209	Pan Head Phillips Screw M6*1.0P*8	1
<b>1.12</b>	000303-202	Phillips Head Screw M5*0.8P*8	1
<b>1.13</b>	006002-009	Flat Washer 5.2*10*1.0t	1
<b>1.14</b>	251305-620	Angle Indicator	1
<b>1.15</b>	924563-000	Pinion Assembly	1
<b>1.16</b>	280272-000	Compression Spring	1
<b>1.17</b>	130378-903	Pinion Shaft Block	1
<b>1.18</b>	000201-105	Socket Set Screw M4*0.7P*4	1
<b>1.19</b>	381388-904	Knob	1
<b>1.2</b>	:006002-056	Flat Washer 8.5*23*2t	1
<b>1.20</b>	000102-102	Cap Screw M5*0.8P*8	2
<b>1.21</b>	574852-000	Angle Ruler	1
<b>1.22</b>	002301-201	Round Head Rivet 2*5	2
<b>1.23</b>	041401-007	Bubble Wrap Bag 600*360*0.05t	1
<b>1.3</b>	310500-911	Fence	1
<b>1.4</b>	003001-102	Hex. Screw 1/4"20NC*1"	2
<b>1.5</b>	090342-008	Miter Gauge	1
<b>1.6</b>	230408-000	Universal Handle	2
<b>1.7</b>	360355-901	Pin	1
<b>1.8</b>	000204-114	Set Screw M8*1.25P*6	2
<b>1.9</b>	381390-904	Bar	1
<b>2</b>	924860-000	Table Insert Assembly	1
<b>3</b>	924861-000	Dado Insert Assembly	1
<b>4</b>	924863-000	14" Blade Guard Assembly	1
<b>5</b>	924864-000	16" Blade Guard Assembly	1
<b>6</b>	924862-000	Fence Assembly	1
<b>6.1</b>	174444-008	Fence	1
<b>6.10</b>	250624-615	End Cap	1
<b>6.11</b>	250471-621	Pad	3
<b>6.12</b>	230282-615	Knob	1

Index	Part Number	Descriptions	QTY
6.13	361399-904	Knob Shaft	1
6.14	000805-101	Button Hex Socket Screw M4*0.7P*6	2
6.15	174854-008	Bracket	1
6.16	000801-108	Button Hex Socket Screw M6*1.0P*8	2
6.17	270080-901	Plate	1
6.18	000004-114	Hex. Screw M10*1.5P*90	1
6.19	008308-100	Lock Nut M10*1.5P(17B*12H)	1
6.2	250472-621	Plastic Set Screw M12*1.75P	2
6.20	924477-000	Cam Assembly	1
6.21	251298-615	POM fastener	2
6.22	001905-103	Set Lock Screw M10*1.5P*8	2
6.23	002103-103	Pan Phillips Lock Screw M6*1.0P*8	2
6.24	171372-904	Bracket	1
6.25	571223-000	Label	1
6.26	041305-056	Plastic Bag 1400*620*0.1t	1
6.27	041306-002	Plastic Bag 190*130*0.15t	1
6.28	924556-000	Styrofoam for rail assembly	1
6.29	520001-892	Cardboard Packaging 1230*460*170(mm)	1
6.3	250799-620	Pointer	2
6.30	TN010901	Crate	1
6.4	172847-905	Pointer Bracket	2
6.5	001101-205	Self-Tapping Screw M3*1.06P*6	4
6.6	000304-210	Phillips Head Screw M6*1.0P*6	4
6.7	251294-621	Linkage	2
6.8	361279-905	Square Screw	12
6.9	008304-100	Lock Nut M6*1.0P(10B*6H)	12
7	TN0115	52" Rail Assembly	1
7.0	TN011501	Bagged Hardware	1
7	174850-008	52" Rail Guide Support Bracket	1
7.1	000704-102	Flat Head Hex. Screw M8*1.25P*25	7
7.10	TN011505	52" Front Rail Assembly	1
7.11	TN011506	52" Rail Guide Support Bracket Assembly	1
7.12	TN011507	52" Rear Rail Assembly	1
7.13	572202-000	Scale (Left) 16"	1
7.14	572537-000	Scale (Right) 52"	1

Index	Part Number	Descriptions	QTY
7.15	041305-004	Plastic Bag 275*195*0.1t	1
7.2	006001-049	Flat Washer 8.5*16*2t	17
7.3	006305-100	Spring Washer 8.2*13.7	14
7.4	008006-100	Hex. Nut M8*1.25P*6.5H	10
7.5	000104-106	Cap Screw M8*1.25P*20	7
7.6	006001-023	Flat Washer 6.3*13*2t	8
7.7	006303-100	Spring Washer 6.5*10.5	8
7.8	000002-104	Hex. Screw M6*1.0P*20	8
7.9	250624-615	End Cap	2
8	TN0116	Extension Table Assembly	1
8.0	TN011601	Bagged Hardware	1
8.1	006003-075	Flat Washer 10.3*22*2t	3
8.10	174872-008	Supporting Bracket	1
8.11	924858-000	Extension Table	1
8.12	174862-008	Supporting Bracket	2
8.13	174870-008	Right Supporting Bracket	1
8.14	174869-008	Lower Supporting Bracket	2
8.15	174871-008	Extension Bracket	1
8.16	190311-008	Supporting Tube/Leg	2
8.2	000004-102	Hex. Screw M10*1.5P*25	3
8.3	006001-032	Flat Washer 6.6*13*1t	20
8.4	000304-107	Phillips Head Screw M6*1.0P*16	12
8.5	000002-101	Hex. Screw M6*1.0P*12	8
8.6	008005-100	Hex. Nut M6*1.0P	4
8.7	009006-100	Hex. Nut 3/8"-16NC(14.2B*8.33H)	2
8.8	230081-000	Foot	2
8.9	230086-901	Self-Tapping Screw	14
9	051452-000	Bed	1
10	251243-615	Knob	1
11	011001-103	Spring Pin 3*10	1
12	006701-100	Waved Washer WW-6	1
13	006001-137	Flat Washer 5.3*16*1.5t	1
14	008302-100	Lock Nut M5*0.8P(8B*6H)	1
15	008007-200	Hex. Nut M10*1.5P*8H	4
16	006307-100	Spring Washer 10.2*18.5	14

Index	Part Number	Descriptions	QTY
17	006001-075	Flat Washer 10.3*22*2t	4
18	043329-000	O Ring P Type P30	4
19.1	901231-000	Motor Assembly7.5HP*230/460V*60HZ*3PH	1
19.1.1	609027-000	Induction Motor7.5HP*230/460V*60HZ*3PH*19.5/9.5A	1
19.1.2	012004-003	Key6*6*40	1
19.1.3	574866-000	Motor Plate7.5HP*230/460V*60HZ*3PH	1
19.2	TN0117	Motor Assembly10HP*230/460V*60HZ*3PH	1
19.2.1	609028-000	Induction Motor10HP*230/460V*60HZ*3PH*27.5/13.5A	1
19.2.2	012004-003	Key6*6*40	1
19.2.3	574230-000	Motor Plate10HP*230/460V*60HZ*3PH	1
20	TN019901	Set Screw M10*1.5P*50L	4
21	381437-902	Motor Pulley 12 Grooves	1
22	001902-101	Set Lock Screw M6*1.0P*10	2
23	TN010020	V Belt 220-J12 220-J12	1
24	008303-100	Lock Nut M14*2.0P	1
25	006001-171	Flat Washer 14.2*26*2t	1
26	001902-109	Set Lock Screw M6*1.0P*6	1
27	381438-902	Belt Pulley	1
28	010107-000	Retaining Ring RTW-47	1
29	001905-103	Set Lock Screw M10*1.5P*8	1
30	660160-000	Blade Brush	1
31	001602-101	Flange Screw M5*0.8P*10/5*12*0.8t	1
32	051450-000	Up/Down Bracket	1
33	174848-904	14" Riving Knife	1
34	174847-904	16" Riving Knife	1
35	381439-902	Mounting Bracket	1
36	011003-112	Spring Pin 5*10	2
37	001902-112	Set Lock Screw M6*1.0P*16	4
38	006303-100	Spring Washer 6.5*10.5	5
39	000103-110	Cap Screw M6*1.0P*35	2
40	381440-902	Washer	1
41	280282-901	Spring	1
42	Contact Oliver	Hex. Screw M16*2.0P*35	1
43	030208-002	Bearing 6204-2NSE	2
44	010010-000	Retaining Ring STW-20	1

Index	Part Number	Descriptions	QTY
45	190309-902	Sleeve	1
46	012003-011	Key 5*5*35	1
47	381436-902	1" Arbor	1
48	380480-901	Blade Washer (1")	1
49	380051-901	Blade Nut (1")	1
50	000104-106	Cap Screw M8*1.25P*20	4
51	660308-000	Gas Strut	1
52	000106-102	Cap Screw M12*1.75P*40	1
53	006001-136	Flat Washer 12.2*23*2.0t	1
54	008311-100	Lock Nut M12*1.75P(19B*12H)	1
55	000104-112	Cap Screw M8*1.25P*40	4
56	006305-100	Spring Washer 8.2*13.7	10
57	361402-000	Column	1
58	361396-000	Column	1
59	051451-000	Trunnion	1
60	000403-103	Pan Head Phillips Screw M6*1.0P*12	2
61	174885-000	Bracket	1
62	000003-104	Hex. Screw M8*1.25P*20	1
63	006001-040	Flat Washer 8*30*3t	1
64	361397-901	UP/Down Worm Shaft	1
65	012003-003	Key 5*5*12	1
66	031005-001	Thrust Bearing 51102	2
67	006001-077	Flat Washer 10.5*19*1t	1
68	008307-200	Lock Nut M10*1.25P(17B*12H)	1
69	160073-000	Bushing	1
70	660144-000	Gasket	1
71	130237-903	Bearing Housing	1
72	001901-101	Set Lock Screw M5*0.8P*5	4
73	380767-000	Bevel Gear	1
74	160076-000	Bushing	1
75	000003-107	Hex. Screw M8*1.25P*35	2
76	008006-100	Hex. Nut M8*1.25P*6.5H	3
77	051453-000	Gear Block	1
78	000302-101	Phillips Head Screw M4*0.7P*6	11
79	021107-100	Wire Buckle ACC-1.5-B	3

Index	Part Number	Descriptions	QTY
80	000304-102	Phillips Head Screw M6*1.0P*10	10
81	006001-022	Flat Washer 6.3*13*1.0t	3
82	000004-105	Hex. Screw M10*1.5P*40	6
83	006001-068	Flat Washer 10*20*2t	16
84	051455-000	Bracket	2
85	008007-100	Hex. Nut M10*1.5P*8H	6
86	230171-916	Knob Bolt	1
87	230114-906	Knob	1
87	230114-906	Handle	1
88	240059-308	Hand Wheel	2
89	004403-103	Set Lock Screw 5-16"-18NC*5-16"	2
90	174861-156	Pointer	1
91	006503-100	Toothed Washer 6.4*11*0.6t	1
92	000103-112	Cap Screw M6*1.0P*45	1
93	360355-901	Pin	2
94	000103-109	Cap Screw M6*1.0P*30	2
95	660002-000	Magnet	2
96	924859-000	Side Blade Cover Assembly	1
97	250705-000	Thumb Screw	1
98	000801-102	Button Hex Socket Screw M6*1.0P*12	2
99	174851-008	Dust Blast Gate	1
100	006006-106	Plastic Washer 19.1*25.4*1.6	4
101	012003-006	Key 5*5*18	3
102	361398-901	UP/Down Shaft	1
103	380768-000	Bevel Gear	1
104	TN010085	Lock Collar	1
105	172110-000	Sensor Plate	2
106	130031-000	Lock Collar	1
107	001903-104	Set Lock Screw M8*1.25P*10	4
108	130061-000	Key	2
109	TN0120	Sensor Assembly	1
110	TN010079	Up/Down Sensor Bracket	1
111	001101-205	Self-Tapping Screw M3*1.06P*6	4
112	000801-101	Button Hex Socket Screw M6*1.0P*10	5
113	950834-000	Sensor Assembly	1



Index	Part Number	Descriptions	QTY
114	TN010080	Angle Sensor Bracket	1
115	006001-009	Flat Washer 5.2*10*1t	10
116	000303-103	Phillips Head Screw M5*0.8P*10	12
117	000104-110	CAP Screw M8*1.25P*30	2
118	230128-916	Knob Bolt	1
119	361401-902	Worm Shaft	1
120	051454-000	Worm Shaft Bracket	1
121	361400-902	Bushing	1
122	011003-107	Spring Pin 5*30	1
123	360371-901	Worm Shaft	1
124	049201-102	Hex w/Flat Washer M8*1.25P*12/(13B*5.5H)	1
125	850579-000	Push Stick & Hardware	1
126	174866-904	Wrench	2
127	170965-904	Bracket	1
128	174865-000	Side Cover	1
129	230297-615	Fixing Bar	2
130	TN010084	Plate	1
131	020003-000	Strain Relief SB7R-3	1
132	020008-000	Strain Relief SBR5-2	2
133	001501-101	Cap w/Spring Washer/Flat Washer M8*1.25P*20 8.2*13.7-8.5*19*2t	8
134	174568-156	Lifting Hook	4
135	174849-000	Cabinet	1
136	000004-102	Hex. Screw M10*1.5P*25	4
137	021332-000	Strain Relief 全冠 MG12A-08B	1
138	021803-000	Snap Ring NB-1925	1
139	491103-000	Transformer	1
140	021201-000	Connector with Nut SW-P3	1
141	174416-000	Cover	1
142	000804-103	Button Hex Socket Screw M5*0.8P*10	6
143	950799-000	Digital Readout Assembly 220~460V	1
143.1	000806-103	Button Hex Socket Screw M3*0.5P*8L	4
143.10	471037-125	Cable 18AWG*1C*250mm*	1
143.11	471037-126	Cable 18AWG*1C*150mm	1
143.2	924873-000	Digital Readout Display Assembly	1
143.3	491160-000	Plastic Bushing HTS-308(M3) (KSS)	4

Index	Part Number	Descriptions	QTY
143.4	491171-000	Control Board 220~460V	1
143.5	491166-000	Plasctic Nut PN-3(M3) (KSS)	4
143.6	490019-000	Key Switch	1
143.7	490040-000	Starting Switch	1
143.8	491153-000	Emergency Stop Switch	1
143.9	471037-083	CSA Cable 18AWG*1C*150mm	1
144	000003-106	Hex. Screw M8*1.25P*30	1
145	491116-008	Conjunction Box Lower Cover	1
146	006502-300	Toothed Washer 5.3*10(BW-5)	2
147	250573-615	Bushing	4
148	490336-000	Terminal HD-30-A3(600V/40A)	1
149	000303-109	Phillips Head Screw M5*0.8P*35	4
150	490124-008	Conjunction Box Upper Cover	1
151	003303-102	Phillips Head Screw 3/16"-24NC*1/4"	1
152	021323-000	Strain Relief 全冠-MGB25-16B	1
153	471008-001	CSA Cable 10AWG*1C*153mm	1
154.1	938015-000	Magnetic Switch Assembly 7.5HP*230/460V*60HZ*3PH*	1
154.1.1	823030-012	Magnetic Switch 7.5HP*230V*3PH	1
154.1.2	170977-901	Back Board	1
154.1.3	003303-101	Phillips Head Screw 3/16"-24NC*1/2"	2
154.1.4	021310-000	Strain Relief PGB21-16B	2
154.1.5	Contact Oliver	Strain Relief PGB16-10B	2
154.1.6	474004-028	CSA Cable SJT 12AWG*4C*1000mm	1
154.1.7	474004-029	CSA Cable SJT 12AWG*4C*760mm	1
154.1.8	474001-019	CSA Cable SJT 18AWG*4C*1500mm	1
154.1.9	473001-036	CSA Cable SJT 18AWG*3C*1000mm	1
154.2	TN0118	Magnetic Switch Assembly 10HP*230/460V*60HZ*3PH*	1
154.2.1	823030-013	Magnetic Switch 10HP*230V*3PH	1
154.2.2	170977-901	Back Board	1
154.2.3	003303-101	Phillips Head Screw 3/16"-24NC*1/2"	2
154.2.4	021310-000	Strain Relief PGB21-16B	2
154.2.5	Contact Oliver	Strain Relief PGB16-10B	2
154.2.6	474005-015	CSA Cable SJT 10AWG*4C*1000mm	1
154.2.7	474005-016	CSA Cable SJT 10AWG*4C*760mm	1
154.2.8	474001-019	CSA Cable SJT 18AWG*4C*1500mm	1

Index	Part Number	Descriptions	QTY
<b>154.2.9</b>	473001-036	CSA Cable SJT 18AWG*3C*1000mm	1
<b>155</b>	002402-102	Phillips Head Lock Screw w/Washer M5*0.8P*10L 5*16*1.5t	4
<b>156</b>	TN010081	Clamp 3.5"	2
<b>157</b>	042620-011	Hose 3" *1000mm	1
<b>158</b>	TN010063	Dust Port	1
<b>159</b>	230403-000	Foot	4
<b>160</b>	174863-000	Side Panel	1
<b>161</b>	230387-000	Door Latch	1
<b>162</b>	340007-615	Fastener	2
<b>163</b>	000401-104	Pan Head Phillips Screw M4*0.7P*10	2
<b>164.1</b>	575163-000	Tilting Scale	1
<b>164.2</b>	572094-000	Oliver Oval Logo Plate OLIVER	1
<b>166</b>	040201-000	Double End Open Wrench 8*10	1
<b>167</b>	040203-000	Double End Open Wrench 11*13	1
<b>168</b>	040205-000	Double End Open Wrench 14*17	1
<b>169</b>	040005-000	Hex Wrench 5mm	1
<b>170</b>	040006-000	Hex Wrench 6mm	1
<b>171</b>	040401-000	Double Ended Screwdriver #1*75	1





# Warranty and Service

Oliver Machinery makes every effort to assure that its equipment meets the highest possible standards of quality and durability. All products sold by Oliver Machinery are warranted to the original purchaser to be free from defects for a period of two (2) years on all parts excluding electronics and motors which are warranted for one (1) year from the date of shipment. Oliver Machinery's obligation under this warranty shall be exclusively limited to repairing or replacing products or parts or components, at its sole option, determined by Oliver Machinery to be defective. Oliver Machinery shall not be required to provide other form of indemnity or compensation including but not limited to compensatory damages.

This warranty is non-transferable and is only extended to the original purchaser from an authorized distributor.

This warranty does not apply to defects due to direct or indirect misuse, abuse, negligence, accidents, unauthorized repairs, alternation outside our facilities, lack of maintenance, acts of nature, or items that would normally be consumed or require replacement due to normal wear and tear.

## **OTHER TERMS**

To obtain and exercise the warranty right, please call 800-559-5065 or fill out warranty request form online at [www.olivermachinery.net](http://www.olivermachinery.net).

Warranty parts are shipped via Parcel or Ground. Additional charges will occur and charge to customers if express shipping is required.

## **DISCLAIMER**

Under no circumstances shall Oliver Machinery be liable for death, personal or property injury, or damages arising from the use of its products.

Oliver Machinery reserves the right to make changes without prior notice to its products to improve function or performance or design.

## **FOR MORE INFORMATION**

If you need assistance or have questions beyond what is covered in the scope of this warranty information, please call 800-559-5065 or email us at [info@olivermachinery.net](mailto:info@olivermachinery.net).





Oliver Machinery is always adding new Industrial Woodworking products to the line.

For complete, up-to-date product information, visit us online at:

[WWW.OLIVERMACHINERY.NET](http://WWW.OLIVERMACHINERY.NET)

or call toll-free 1-800-559-5065

**\*\* SAVE THIS MANUAL FOR FUTURE REFERENCE. \*\***