

Drill Press Models

10060/10061

Owner's Manual

For Models Manufactured Since 04/2022



10060



10061



Oliver Machinery
1-800-559-5065
921 Thomas Ave SW,
Renton, WA 98057

info@olivermachinery.net
WWW.OLIVERMACHINERY.NET

Stock Number: 10060.001
10061.001

Manual Version: 2.1.1



READ AND UNDERSTAND ALL INSTRUCTIONS IN THIS MANUAL BEFORE ATTEMPTING TO ASSEMBLE OR OPERATE THE MACHINE.

FOLLOW THE INSTRUCTIONS AND THINK SAFETY!

THE OWNER OF THIS MACHINE IS SOLELY RESPONSIBLE FOR THE SAFETY OF ANYONE USING THIS MACHINE. SUCH RESPONSIBILITY INCLUDES BUT NOT LIMITED TO THE FOLLOWING:

- **PROPER ASSEMBLY, OPERATION, INSPECTION, MAINTENANCE, AND RELOCATION OF THE MACHINE.**
- **PROPER TRAINING FOR THE OPERATORS AND ENSURES THIS MANUAL IS AVAILABLE AT ALL TIMES.**
- **USAGE AUTHORIZATION.**
- **USAGE OF SAFETY AND PROTECTION DEVICES.**

OLIVER MACHINERY DISCLAIMS ANY LIABILITY FOR MACHINES THAT HAVE BEEN ALTERED OR ABUSED. OLIVER MACHINERY RESERVES THE RIGHT TO EFFECT AT ANY TIME, WITHOUT PRIOR NOTICE, THOSE ALTERATIONS TO PARTS, FITTINGS, AND ACCESSORY EQUIPMENT WHICH THEY MAY DEEM NECESSARY FOR ANY REASON WHATSOEVER.

**** SAVE THIS MANUAL FOR FUTURE REFERENCE. ****

PROP 65 NOTICE

WARNING: Drilling, sawing, sanding, or machining wood products can expose you to wood dust and/or other chemicals that are known to the State of California to cause cancer, birth defects, or other reproductive harm.

Some examples of these chemicals are:

- Lead from lead-based paints.
- Crystalline silica from bricks, cement, and other masonry products.
- Arsenic and chromium from chemically treated lumber.

Avoid inhaling wood dust and other harmful chemicals. Use a dust mask and/or other safety devices for personal protection.

For more information, visit <http://www.P65Warnings.ca.gov/wood>

Table of Contents

Introduction	5	Operation	27
Specifications	6	Preparation	27
Identification	9	Adjusting Drill Press	29
Safety	11	Table Adjustments	29
General Safety Guidelines	11	Changing Drill Bits	30
Safety Guidelines Specific to Drill Press	12	Changing Speed.....	31
Electricals	14	Adjust Depth Stop	31
Minimum Circuit Size Requirement	14	Changing Chuck.....	32
Grounding	14	Drilling	33
Electrical Wiring	14	Accessories	34
Setup	15	Maintenance	35
Shop Preparation	15	Maintenance Schedule	35
Space Requirement	15	Troubleshooting	36
Load Limits	15	Mechanical / Electrical Issues	36
Electricals	15	Operation / Quality-Related Issues	37
Lighting.....	15	Wiring Diagram	38
Safety Labels	15	Parts List	39
Dust Collection	15	Maintenance Record	43
Receiving	16	Notes	44
Moving Machine into the Shop.....	16	Warranty and Service	45
Unboxing	16	Appendix	46
Inventory.....	17	US Standard – Metric Conversion Chart	46
Cleaning	19		
Assembly	20		
Test Run	25		

Introduction

Thank you for choosing Oliver! This manual contains important information on how to safely set up, operate, and maintain this machine. Please take the time to read through this manual and make sure you understand all instructions.

While this manual may provide tips on improving the result of your workpiece, the manual is not intended as a substitute for formal woodworking or metalworking training. If you need to know how to safely complete a task, please consult knowledgeable and qualified sources before proceeding further.

We made every effort to keep this manual up-to-date. Instructions, specifications, drawings, and photographs in this manual should match the machine delivered. If you find any differences, or anything that seems confusing in this manual, or some instructions are not available, please check our website for an updated version:

WWW.OLIVERMACHINERY.NET/MANUALS

Alternatively, you can contact our technical support for help:

1-800-559-5065

Before calling, please note down the serial number of the machine. You can find the information on a label located on the right side of the headstock. This information is needed to provide proper technical support and to determine if an updated manual is available for your machine.



Please let us know how well this manual serves you. If you have any suggestions, please call the number above or email us at:

info@olivermachinery.net

We love to hear from our customers and make improvements.

Specifications

Quick View

<i>Model</i>	10060 Drill Press	10061 Drill Press
<i>Stock Number</i>	10060.001	10061.001
<i>Type</i>	Bench Top Drill Press	Floor Drill Press
<i>Motor</i>	TEFC Induction Motor, 1/2 HP, 115V, 1Ph	
<i>Speed Range</i>	280 – 3000 RPM	
<i>Swing</i>	13-1/4"	
<i>Drilling Capacity (Mild Steel)</i>	3/4"	
<i>Chuck</i>	JT-3 Key Chuck with 5/8" capacity	
<i>Table</i>	Round Cast Iron Table with 11-1/2" Diameter	
<i>Spindle Travel</i>	3-3/8"	
<i>Max Spindle to Table Distance</i>	18"	30-1/2"
<i>Dimensions</i>	38-1/2"(H) x 14"(W) x 23"(D)	61"(H) x 14"(W) x 23"(D)
<i>Footprint</i>	10"(W) x 16-1/2"(D)	10-1/2"(W) x 17-1/2"(D)
<i>Weight</i>	99 lbs.	112 lbs.
<i>Warranty</i>	1 Year (Motor and electronics) 2 Years (All other parts)	

Product Dimensions

<i>Stock Number</i>	10060.001	10061.001
<i>Assembled Dimensions</i>	38-1/2"(H) x 14"(W) x 23"(D)	61"(H) x 14"(W) x 23"(D)
<i>Footprint</i>	10"(W) x 16-1/2" (D)	10-1/2"(W) x 17-1/2" (D)
<i>Fully Assembled Weight</i>	99 lbs.	112 lbs.

Shipment Info

<i>Stock Number</i>	10060.001	10061.001
<i>Type</i>	Cardboard box	
<i>Content</i>	Drill press and accessories	
<i>Dimensions</i>	31-1/2" (L) x 18"(W) x 11"(H)	55" (L) x 19"(W) x 9"(H)
<i>Weight</i>	106 lbs.	121 lbs.
<i>Approximate Setup Time</i>	90 minutes	
<i>Must Ship Upright</i>	NO	
<i>Stackable</i>	YES	

Electricals

Stock Number	10060.001	10061.001
Power Requirement	115V, 1Ph, 60Hz	
Full Load Current Rating	8A	
Recommended circuit size	15A	
Power Switch Type	Push button switch with safety mechanism	
Connection Type	NEMA 5-15 Plug with 60" 18 AWG Cord	

Motor

Motor Type	TEFC Induction Motor	
Horsepower	1/2 HP	
Speed	1720 RPM	
Power Transfer Mechanism	V-belt and pulleys	
Bearing type	Permanently sealed ball bearing	

Spindle

Stock Number	10060.001	10061.001
Swing	13-1/4"	
Travel	3-3/8"	
Spindle taper	MT-2	
Max. spindle to table distance	18"	30-1/2"
Max. spindle to base distance	25-1/4"	48"
Quill diameter	1.575"	

Chuck

Capacity	5/8"	
Type	JT-3 Key Chuck	

Speed and Drilling Capacity

Spindle Speed Range	280 – 3000 RPM	
Total number of speeds available	12	
Drilling Capacity (Mild Steel)	3/4"	

Table

<i>Stock Number</i>	10060.001	10061.001
<i>Table Shape and Dimensions</i>	Round, 11-1/2" Diameter	
<i>Max. Table Tilt</i>	+/- 45°	
<i>Table Swivel Around Column</i>	360°	
<i>Number of slots</i>	6	
<i>Table Height Above Ground</i>	9" – 24"	19" – 44-1/4"
<i>Table Lifting Mechanism</i>	Rack and Pinion	
<i>Material</i>	Precision ground cast iron	

Base and Column

<i>Stock Number</i>	10060.001	10061.001
<i>Base Dimensions</i>	10" (W) x 16-1/2" (D)	10-1/2" (W) x 17-1/2" (D)
<i>Base Material</i>	Cast iron	
<i>Column Diameter</i>	2-7/8"	
<i>Column Material</i>	Steel	

Measurements

<i>Measurement Unit</i>	Inch
<i>Measurement Devices</i>	Depth Scale
<i>Laser Center Finder</i>	Equipped

Safety

<i>Chuck Guard</i>	Polycarbonate Chuck Guard
<i>Sound Rating @ 2' distance</i>	82 dB
<i>Center Finder Laser Class</i>	Class II

Others

<i>Serial Number Location</i>	On the left side of the headstock
<i>Work Lamp Type</i>	LED
<i>Certification</i>	CSA 183999
<i>Country of Origin</i>	China

Identification

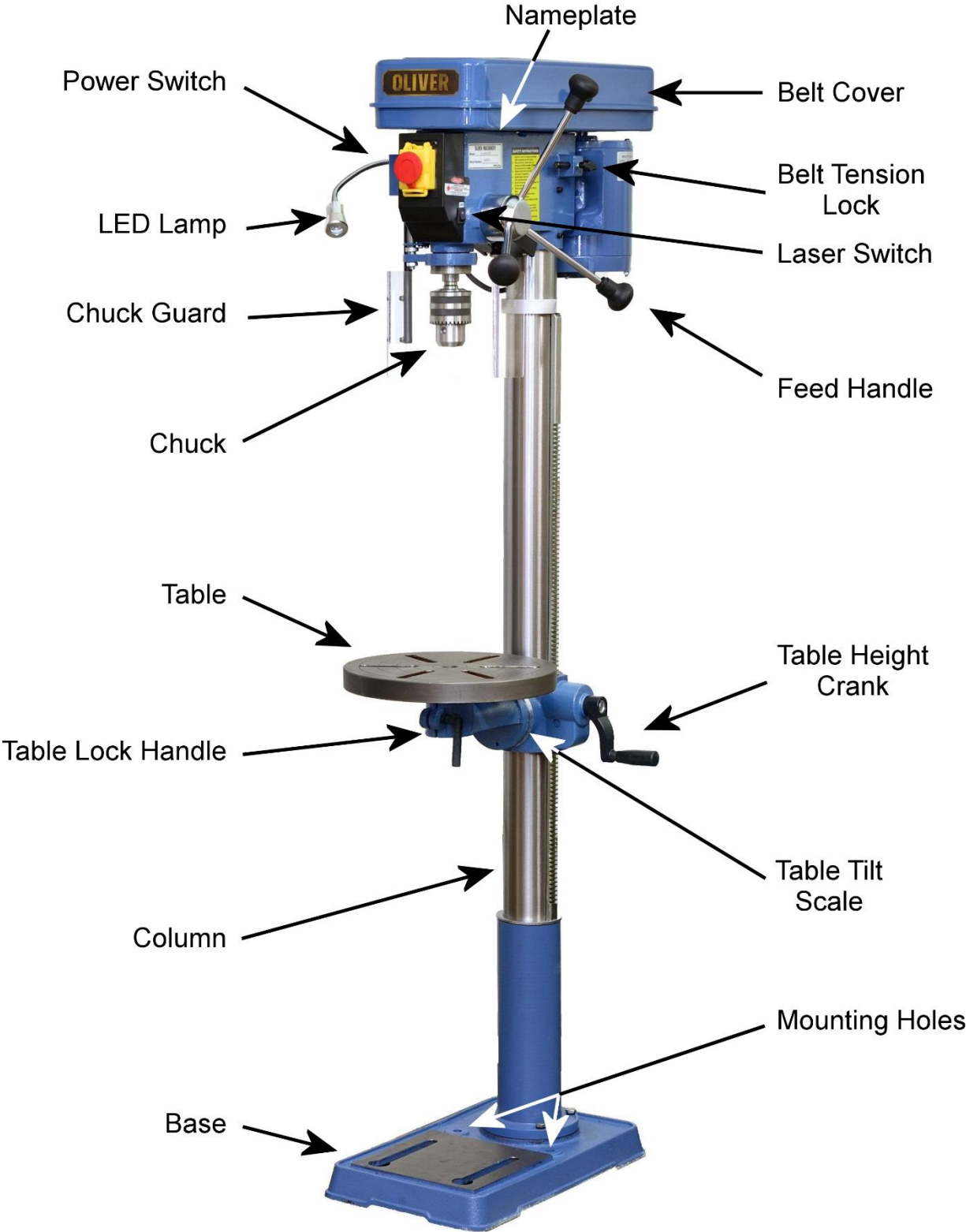

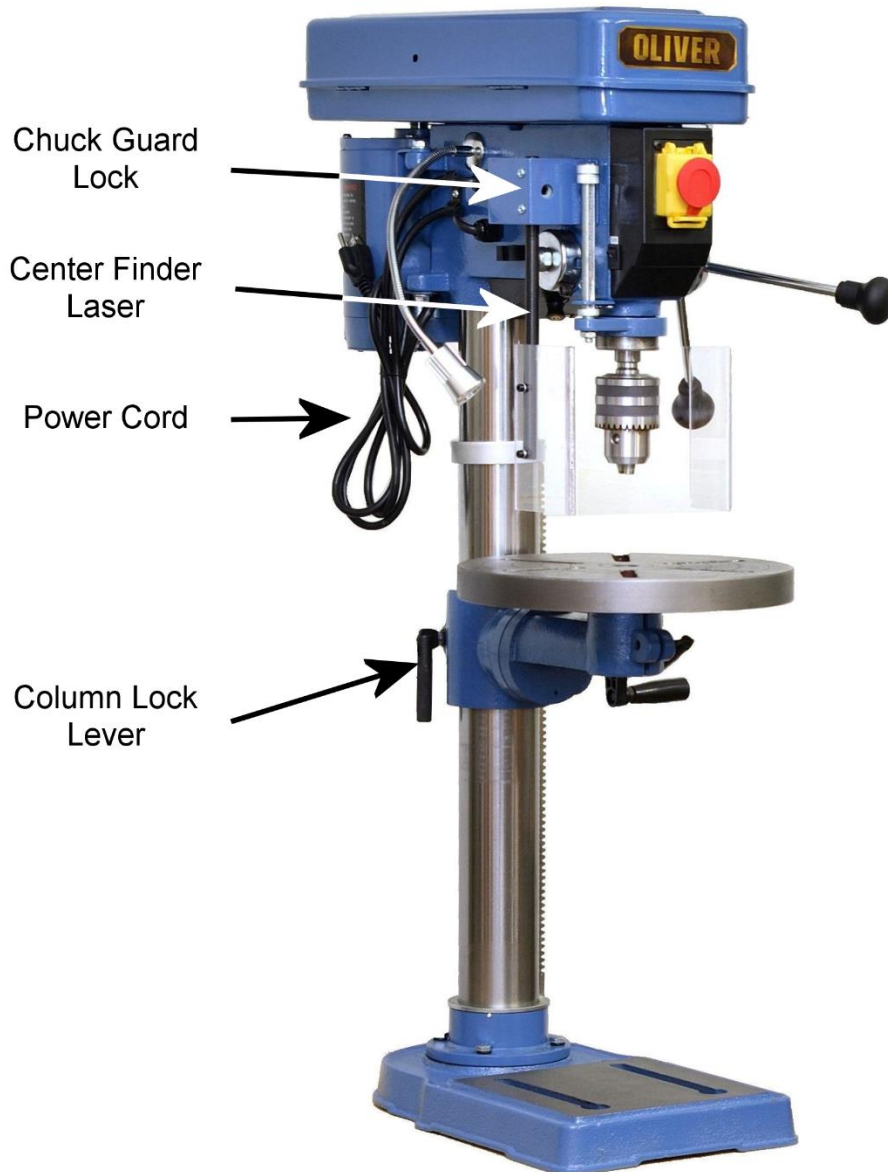

Chuck Guard
Lock



Center Finder
Laser

Power Cord

Column Lock
Lever

Safety

Oliver Machinery has made every attempt to provide a safe, reliable, easy-to-use piece of machinery. Safety, however, is ultimately depending on the individual machine operator. **Before operating this machine, please become familiar with the following safety labels and guidelines.**

 DANGER	This indicates an imminently hazardous situation which, if not avoided, WILL cause death or serious injury.
 WARNING	This means if the warning is not taken seriously, it CAN cause death or serious injury.
 CAUTION	This means if precaution is not taken, it MAY cause injury.
IMPORTANT	This is a tip for properly operating the machine to avoid machine damage.

General Safety Guidelines

1. **FAMILIARIZE** yourself with all safety instructions found in this manual. Know the limitations and hazards associated with this machine. Do not operate/service this machine until you are properly trained.
2. **ELECTRICAL GROUNDING**, when done properly, reduce the risk of electrocution, shocks, and fire. Make certain that the machine frame is electrically grounded and that a ground lead is included in the incoming electrical service. In cases where a cord and a plug are used, make certain that the grounding plug connects to a suitable ground. Follow the grounding procedure indicated in the electrical code of your area.
3. **DISCONNECT** the machine from power before performing any service, maintenance, or adjustments. A machine under repair should be RED TAGGED to show it should not be used until the repair is complete.
4. **EAR PROTECTION**: Use hearing protective devices where the noise exceeds the level of exposure allowed in Section 1910.95 of the OSHA Regulations. When in doubt, use it.
5. **GUARDS**: Keep machine guards in place for all applicable operations. If any guards are removed for maintenance, DO NOT OPERATE the machine until all guards are reinstalled. Check clearance between the guards and the cutter before starting the machine.
6. **WORKPLACE SAFETY**: Keep the floor around the machine clean. Scrap material, sawdust, oil, and other liquids increase the risk of tripping or slipping. Be sure to clean up the table before starting the machine. Make certain the work area is well-lighted and that a proper exhaust system is used to minimize dust. Use anti-skid floor strips on the floor area where the operator normally stands and mark off the machine work area. Wear protective footwear. Provide adequate workspace around the machine.
7. **ACCESS CONTROL** should be enforced so only trained personnel can access the work area and operate the machine. Use a childproof power switch when applicable.
8. **STAY ALERT** at all times. Do not operate this machine while under the influence of drugs/alcohol or when not feeling well.

9. **NEVER STAND ON MACHINE.** This prevents injuries from tipping-related accidents and accidental contact with cutters.
10. **REPLACEMENT PARTS:** Use only genuine Oliver Machinery replacement parts and accessories recommended for this machine. Generic parts made by other manufacturers may create a safety hazard and WILL void the factory warranty and other guarantees.
11. **PROPER USE:** Do not use this machine for anything other than its intended use. If used for other purposes, Oliver Machinery disclaims any real or implied warranty and holds itself harmless for any injury or damage which may result from that use.

Safety Guidelines Specific to Drill Press

Before Work Begins:

1. **INSPECT WORKPIECE:** This drill press is primarily designed for woodworking operations, and it is also suitable for drilling some other materials, such as soft steel. Avoid drilling materials that may disintegrate or catch fire. Avoid drilling materials that contain harmful chemicals, as this can produce harmful chemical dust.
2. **CHECK DRILL BIT AND CHUCK:** Make sure the drill bit is sharp, clean, balanced, and free from damage. Replace dull or damaged drill bit. Never use a drill bit to drill material types that it is not compatible with. Make sure the drill bit is securely fastened and the chuck key is not attached to the chuck before starting the drill press.
3. **USE CORRECT SPINDLE SPEED:** Some drill bits have a maximum operating speed recommended by the manufacturer. Never set the drill press to go beyond this speed, or the drill bit can overheat or even disintegrate, which can cause serious injuries or even death.
4. **SECURE WORKPIECE, TABLE, AND HEADSTOCK:** Mount the workpiece on the table with clamps or drill vise. Never hold the workpiece by hand during operation. Lock the table assembly to maintain the alignment between the drill bit and the workpiece. Failure to do so may cause the drill bit to bind into the workpiece. This can damage the drill bit and the workpiece, and cause serious injuries.
5. **EYE PROTECTION:** Always wear an approved safety face shield/goggles/glasses that complies with ANSI Z87.1 and CSA Z94.3 standards. Common eyeglasses are not safety glasses and may not provide adequate protection.
6. **LASER WARNING:** This drill press is equipped with a class II laser center finder. DO NOT stare into the laser beam or view it directly with an optical instrument.
7. **AVOID ENTANGLEMENT:** Roll up sleeves above elbows. Remove all loose outer clothing and confine long hair. Remove tie, rings, watch, and other jewelry. Do not wear gloves unless it is instructed to perform certain steps in the manual.
8. **CHECK CHUCK GUARD:** Make sure the guard is installed and there are no signs of damage. Before starting the drill press, shield the chuck with the guard and lock it in place.

9. **PROTECT TABLE:** The drill bit should align with the center hole on the table. For drill bits like Forstner bits, the center hole may not be big enough for the drill bit to pass through. Support the workpiece with a backer board to protect the tool and avoid tearing out the back of a workpiece.
10. **SUPPORT LONG WORKPIECE** to prevent the workpiece and the drill press from tipping.
11. **DUST COLLECTION SYSTEM** reduces harmful dust from drilling. Please set up the drill press with dust extraction accessories when available.
12. **NOT A MILLING MACHINE:** A drill press is only designed for downward cutting. Never use the drill press for sideway cutting with milling bits. Doing so can damage the drill press and cause the chuck to dislodge from the drill press.

When Drilling:

1. **THE 3-INCH RULE.** Keep your hands at least three inches away from the drill bit when the machine is running. Do not clear debris with your hands while the drill press is running.
2. **PROPER FEEDING** keeps the workpiece under control. NEVER start the drill press with the drill bit engaging the workpiece. NEVER start drilling into the workpiece until the motor has reached its full speed. Maintain proper feed rate and downward pressure.
3. **DRILLING ANGLED HOLES:** Be extra careful when drilling angled holes. The lateral force may cause the drill bit to twist and break. Reduce feed rate and use sharp bits.
4. **PREVENT OVERHEATING** by using lubricant when drilling metal, plastic, and some other non-wood materials. Overheating damages the workpiece and the drill bit, and creates a fire hazard.

After Operation

1. **STOP THE MACHINE** if the operator leaves the machine for any reason.
2. **WAIT** until the machine comes to a complete stop.
3. **CLEAN UP** and **CLOSE POWER SWITCH COVER** before departure.

Electricals

	Faulty electrical work can cause electrocution and is a fire hazard.
WARNING	All electrical work must be completed by a licensed electrician and must meet the local electrical code in your area, or the warranty is void.

Minimum Circuit Size Requirement

Model	Minimum Circuit Size Required
10060 Drill Press	15A
10061 Drill Press	15A

Please ensure the electrical circuit for this machine meets the minimum circuit size requirement. The minimum circuit size requirement applies to a dedicated circuit that provides power to one drill press. If more machines are sharing the same circuit, consult a licensed electrician to ensure the designated circuit is properly sized for safe operation.

If a circuit is available but not meeting the minimum circuit size requirement listed above, a new circuit must be installed for this machine.

Grounding

	Improper grounding can cause electric shock, fire, and equipment damage.
WARNING	

Proper grounding reduces the risk to the operator in the event of electrical malfunction or breakdown. This machine must be connected to the grounding conductor when available, and all grounding connections must meet or exceed the electrical code requirements in your area. Furthermore, all grounds must be verified and must meet or exceed the electrical requirement of the machine. If grounding is not available, consider the use of a GFCI protection device as an alternative if this complies with the electric code in your area.

Electrical Wiring

This machine is pre-wired for 115V with a cord and a NEMA 5-15 plug. The drill press should be situated near an electrical outlet. If you need to use an extension cord to connect to a power source, select a durable cord type with high-temperature rating (90C° or above). Use the minimum amount of extension cord as needed.

Minimum cord size (AWG) required based on amperage draw and length of the cord:

Amps	Power Cord Length				
	25 feet	50 feet	75 feet	100 feet	> 100 feet
5 to 8	14	14	14	12	Not Recommended
8 to 12	14	14	12	10	
12 to 15	12	12	10	10	

	Use properly sized wires that meet or exceed the power requirement of your machine. Using undersized wires may cause overheating and increase the risk of fire and machine damage.
WARNING	

Setup

Shop Preparation

Space Requirement

The dimensions of 10060 Drill Press and 10061 Drill Press are 38-1/2"(H) x 14"(W) x 23"(D) and 61"(H) x 14"(W) x 23"(D) respectively. You will need additional space for manipulating your workpiece, electrical connection, and dust collection.

Load Limits

This series of drill presses can weigh up to 121 lbs. Please ensure all lifting tools and structures have adequate load capacity for transporting and supporting the total weight of this machine, the operator, and related items.

Electricals

Ensure a properly sized circuit is nearby the machine. If the machine is to be hardwired, there must be a readily accessible power disconnect nearby so that the machine can be disconnected from the power source for servicing and adjustments. If the machine is to be connected with a cord and a plug, please ensure a matching outlet is installed nearby.

Please refer to the section "Electricals" in this manual for details regarding electrical requirements.

Lighting

Install overhead, non-glare lighting for the work area near the drill press. The drill press also comes with a flexible gooseneck LED light to provide a focused beam.

Safety Labels

If this machine introduces a new safety hazard to your workplace, display proper warning signs in highly visible locations.

Dust Collection

Wood dust is a health hazard and can be reduced by using a dust collection system. When it can be done safely, mount a dust hood near the table to remove dust. Check the air suction of the dust collection system regularly to ensure filters and pipes are not clogged.

Dust masks should be available for using the drill press.



Receiving

Your shipment should come in one box. Upon receiving your shipment, check for any significant damages before signing the delivery confirmation. Please keep all packaging materials until this drill press passes the test run (see page 25 for details) and you are satisfied with this machine.

IMPORTANT

If items are damaged on arrival, please call us immediately at **1-800-559-5065**

Moving Machine into the Shop

Your machine will be delivered by freight service, and it will be left outside of your workshop by default. On the day of delivery, please be sure help is available to move the machine to its final location.



WARNING

10060 Drill Press has a shipping weight of 106 lbs. and 10061 Drill Press has a shipping weight of 121 lbs.

Safe moving techniques and proper lifting equipment are required, or serious personal injury may occur.



WARNING

Your shipment may be secured by the straps. Do not lift your shipment by the strap. They are not designed to hold the total weight of your shipment. They may snap without warning and cause serious injury and machine damage.

Always wear safety goggles and gloves when removing straps, as they may spring back violently when released and cause injury.

Unboxing

You should find all parts and accessories packed inside a box like this.



Inventory

Carefully unwrap the packaging and inventory the items received:



<i>Item</i>	<i>Description</i>	<i>Quantity</i>
1	Headstock	1
2	Column, rack, and rack collar	1
3	Table	1
4	Base (Note: The base of 10060 and 10061 are different)	1
5	Table Support Bracket	1
6	Bolts for mounting the column	4
7	Spring washers	4
8	Chuck Guard Rod	1
9	Chuck Guard Screen	1
10	Feed Handles	3
11	Table height adjustment crank	1
12	Belt cover knob	1
13	Arbor	1
14	Chuck	1
15	Chuck key	1
16	Drift key	1
17	Hex key set (3mm & 4mm)	1

NOTICE: If you cannot find an item in the list above, please check if it is still attached to the packaging. Occasionally the item may have been pre-installed in the factory. See "**Parts List**" on page 39 to check if a component is included or installed.

NOTICE: This machine comes with various standard-sized, non-proprietary parts. If any of these parts are missing, we are happy to deliver them to you. To have the machine up and running as soon as possible, you can also find these parts at your local hardware store.

Additional Items Recommended for Machine Setup

<i>Item</i>	<i>Purpose</i>
<i>Safety Glasses</i>	Protection
<i>Disposable Gloves</i>	Protection
<i>Paper Towel / Rags</i>	Cleaning
<i>Rust Inhibitor</i>	Cast iron rust protection.
<i>Metric Wrench Set</i>	Assembly
<i>Metric Hex Wrench Set</i>	Assembly
<i>Retaining Ring Plier</i>	Assembly

Cleaning

To prevent rusting during transportation and storage, the unpainted cast iron surface of this drill press is protected by heavy-duty rust preventive grease and plastic film. The machine should be cleaned before assembly. Remove the packaging and wipe off the grease with paper towels or rags. WD-40 can thin the grease and make cleaning easier. Do not use harsh solvents such as acetone which can damage the paint, and **NEVER** use gasoline or any highly flammable solvent as degreaser.



After the initial cleaning, routinely coat the unpainted cast iron surface with rust preventive such as Boeshield® T-9 or paste wax. Do not use rust preventives that contain silicone, which is known to interfere with certain finishes and glues.



WARNING

Never use gasoline or any highly flammable chemical as degreaser. These chemicals can cause fire and explosion.

Discard oily rags in a fireproof container and keep them away from combustible materials. Oily rags can heat up and trigger spontaneous combustion under certain conditions.

Assembly

This machine must be assembled before it can be operated. Please refer to the section "Inventory" on page 17 and gather the items by their numbers for assembly.



WARNING

Drill press 10060 and 10061 can weigh up to 121 lbs. and it is top-heavy. It is recommended to have at least two adults assemble and move the drill press. Serious injury and machine damage can occur when the drill press is not handled properly.

Drill press Assembly

1. Bolt the column (#2) to the base (#4) using four sets of bolts (#6) and the spring washers (#7).

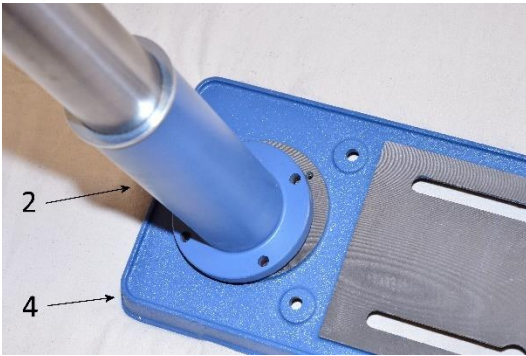

2. Loosen the screw on the rack collar, then slide the rack collar off from the column (#2). Set the rack and the collar aside.

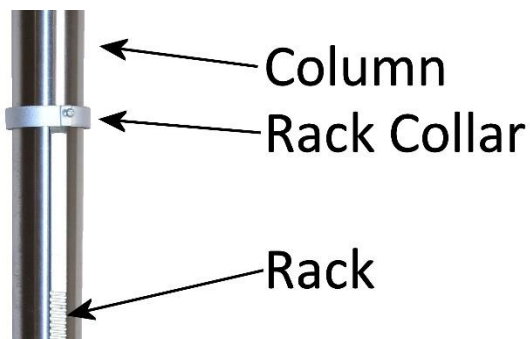

3. Locate the table bracket (#5). Make sure the worm gear and the pinion are in their proper location.

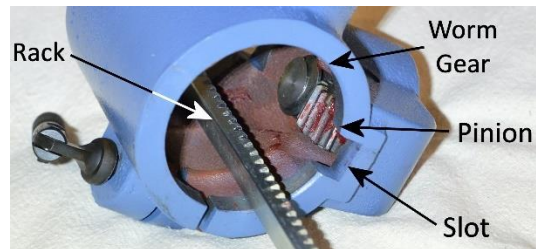

4. Seat the rack into the slot of the table bracket so the rack makes contact with the pinion. Make sure the table bracket and the rack are properly oriented. The table bracket has a dome-shaped top, and the rack has the tapered end pointing up.

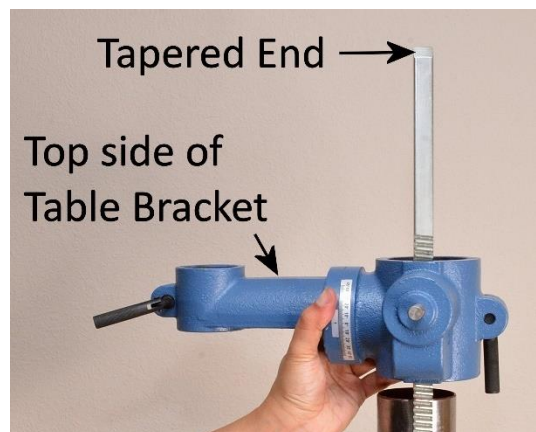

5. Slide both pieces onto the column (#2). Make sure the rack seats inside the table bracket slot in this step, as this is a tight fit.

- Fit the squared end of the rack into the friction ring of the base flange.



- Secure the rack by reinstalling the rack collar. The tapered edge of the collar must face down to hold the rack on the column. Leave a small gap between the collar and the rack, so they don't bind. Do not over-tighten the rack collar screw, as that may damage the column.

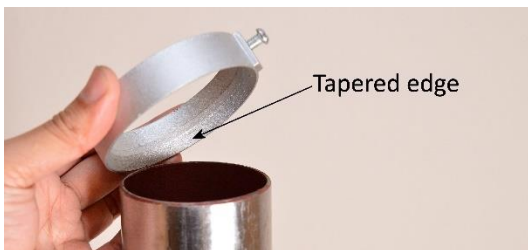

- Slide the table crank handle (#11) onto the worm gear shaft. Make sure the set screw aligns with the flat surface on the shaft. Tighten the set screw with a 3mm hex wrench to secure the handle.



- Have two people lay the headstock on the floor on its side, then fit the column all the way into the headstock.



IMPORTANT

Do not lift the heavy headstock by the power switch or the power cords. Doing so may damage the machine.

- Tighten the set screws on the headstock to temporarily secure the headstock to the column. Do not over-tighten the set screws as that may damage the column.



- With two people, lift the drill press by the headstock. A third person may be needed to keep the base on the ground from sliding.

12. Once the drill press is in the upright position, hang a plumb bob from the center of the headstock. Loosen the headstock set screw to align the spindle with the center of the base, then retighten the set screws.



13. Insert the table (#3) into the table support bracket (#5). Tighten the table lock lever to keep the table in place.



14. Remove the retaining ring from the chuck guard rod (#8) using a pair of retaining ring pliers or a small flathead screwdriver.

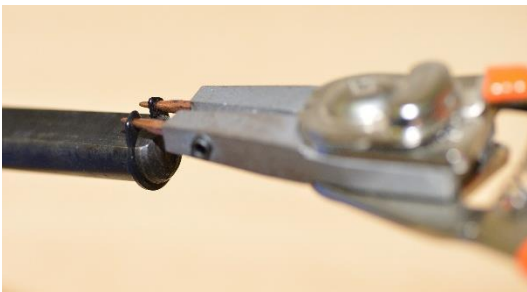

15. Insert the chuck guard rod through the mounting bracket.



16. Reinstall the retaining ring.



17. Remove the socket head cap screws and the washers that are pre-installed on the chuck guard rod, then use the hardware to mount the polycarbonate guard screen (#9). Place the washer in between the screw and the screen. Do not overtighten the screws, or the screen may crack.

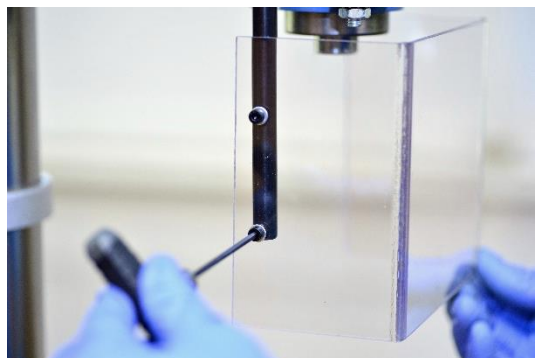

18. Thread the feed handles (#10) into the spindle hub.

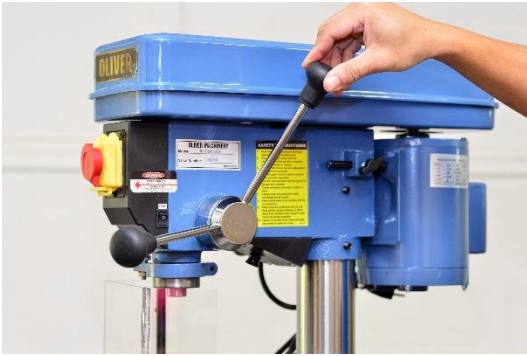

19. Remove the screw from the belt cover. Lift the belt cover and use this screw to mount the belt cover knob (#12).



Drill Chuck Assembly

1. Remove the protective coating from the arbor (#13), drill chuck (#14) internal tapered surface, and spindle internal tapered surface. To ensure the chuck is securely attached to the drill press, the contact surface of these components must be clean.
2. Adjust the drill chuck so all chuck jaws are recessed into the body.
3. Insert the short-tapered end of the arbor into the drill chuck.



4. Insert and twist the arbor until the two parts are joined together.
5. Tighten the joint by tapping the chuck straight down on a piece of wood with medium force. Attempt to detach the arbor from the chuck by hand. If the arbor is detached, repeat steps [3-5].
6. Once the arbor and chuck are joined, it is recommended to keep them attached permanently. If you need to purchase a new chuck, make sure the new chuck has a matching arbor.

7. Make sure the jaws are recessed into the chuck body, then insert the arbor into the quill.

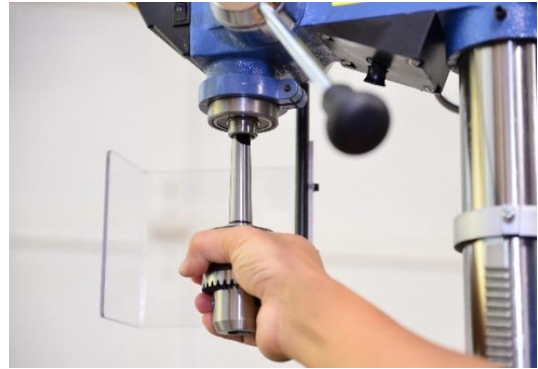

8. Place a block of wood on the table, then lower the spindle assembly with the feed handle to press the chuck against the woodblock. The chuck arbor should form a tight joint with the quill.



9. Attempt to detach the chuck by hand. If the chuck is detached, make sure the joint is clean, and repeat steps [7-8].

Test Run

After the drill press is assembled, complete this test run to make sure the machine is ready for operation. If you discover any issues, STOP the drill press immediately and disconnect it from the power source. Resolve the issue using the troubleshooting guide on page 36 before restarting the machine.

Before the test run, please unplug the drill press and remove all assembly tools and debris from the drill press. Before starting the drill press, ensure the chuck is securely attached to the spindle, and the chuck guard is shielding the chuck and locked in position.

Inspect Drive Belt

1. Open the belt cover and make sure the drive belts do not deflect more than 1/2" when compressed gently between the pulleys.



2. Check the belt tension lock to make sure it is tightened.



3. Make adjustments when needed. When the belts are tensioned, close the belt cover, then plug in the machine for the next test.

Power Switch and Motor Test

This drill press is equipped with a button switch with a spring-loaded emergency stop/cover.

Start the drill press by sliding the emergency stop button upwards. This will unlatch the cover. Lift the cover, then press the green ON button.

NOTICE: The cover must stay unlatched while the drill press is running.



Stop the drill press by pressing the STOP button. This will also close the cover and make the ON button inaccessible.

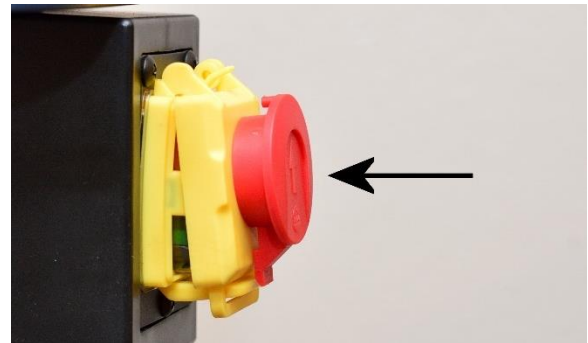

NOTICE

If the power goes out while the drill press is running, the drill press will not start automatically when power resumes. Press the ON button to restart the drill press.

To test the line interruption switch:

1. Make sure the drill press is connected to the power source.
2. Press ON to start the drill press.
3. Unplug the drill press.
4. Reconnect the drill press to the power source. The drill press should not start.
5. Press the ON button again, and the drill press will start.

To test the LED lamp:

1. Toggle the ON/OFF switch on the left side of the headstock. The lamp should turn on and off accordingly.

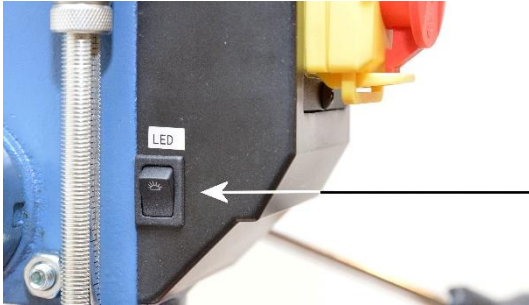

To test the laser center finder:

1. Toggle the ON/OFF switch on the right side of the headstock. The center finder laser should turn on and off accordingly.

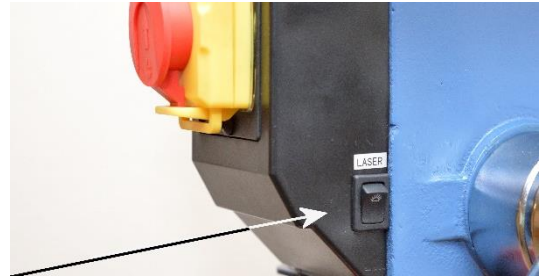

Congratulations! You have completed the test run! Now your drill press is ready to use. If you discover any issues from the tests, please refer to the troubleshooting guide to diagnose issues and make adjustments.

Operation

Preparation

For safety and to achieve the best results, please take the following steps before drilling on a workpiece.

Inspect Workpiece

This drill press is primarily designed for woodworking operations, and it is also suitable for drilling materials such as soft steel. Avoid drilling materials that may disintegrate or catch fire. Avoid drilling materials that contain harmful chemicals, as this can produce harmful chemical dust.

Follow Personal Protection Guidelines

Review the safety guidelines in section "Safety" on page 11 before using the drill press.

Select Suitable Cutter Type

Use the drill bit that is compatible with your workpiece. Using a wrong type of drill bit can cause the workpiece and/or the drill bit to burn or shatter, which can result in serious injuries.

Inspect and Install Drill Bit

Make sure the drill bit is clean, sharp, and free from defects. Make sure the drill bit is securely fastened so it will not dislodge while the drill press is running. After installing the cutter, remove the chuck key and keep it in a safe place.

Mark the Drill Holes

Mark the holes for drilling. For drilling wood or soft metal, using a center punch to create a small dent at the center before drilling can prevent the drill bit from walking and missing the mark.



Adjust Table Height and Position

Adjust the table to the correct height so the drill bit can at least reach down to the desired drill depth. Adjust the table position so the drill bit will not make contact with the table. Using a sacrificial backer board for drilling wood can prevent tearouts.

Make sure the table and the table supporting bracket are locked in place when adjustments are made.

See section "Table Adjustments" on page 29 for how to adjust the table height and positions.

Secure Workpiece

Firmly secure the workpiece on the table using a drill vise or T-Slot clamps. NEVER hold a workpiece by hand. Support oversized workpieces to prevent tipping.

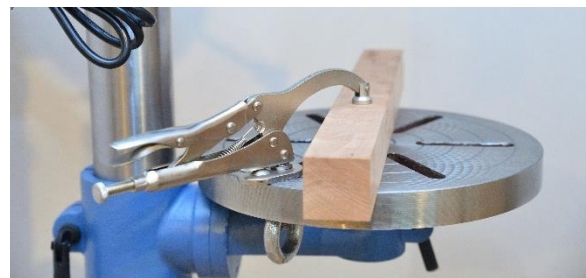

Set Drill Depth

Using the depth stop to set the drill depth. This makes drilling more repeatable and prevents damaging the workpiece.

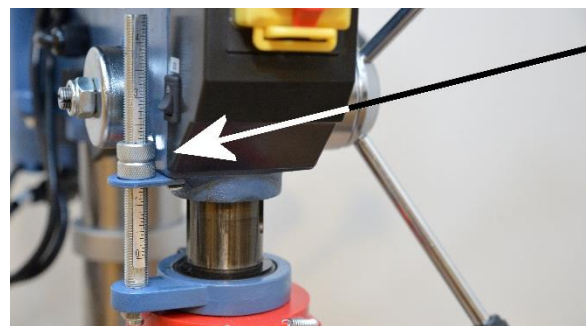

See section "Adjust Depth Stop" on page 31 for details.

Set Spindle Speed

Consider the following when setting the speed before drilling:

1. The size of the drill bit.
2. Type of cutter.
3. Material hardness and other properties.
4. Feed rate and other factors

Please refer to the guidelines from the manufacturer of the cutting tool for setting the optimum spindle speed. In general, use higher spindle speed for small cutters and soft materials, and vice versa.

See section "Changing Speed" on page 31 for details.

Oliver Machinery Model 10060.001 / 10061.001 12-Speed Drill Press		
	A	1
	B	2
	C	3
	D	4
Warning	Belt Position	Spindle RPM
Only Change Spindle Speeds With Machine Unplugged From Power	D-1	280
	C-1	430
	D-2	450
	B-1	580
Always Wear Safety Glasses and Clamp Workpiece at All Times	C-2	680
	D-3	700
	A-2	1300
Use Recommended Speed for Drill Bit Size and Workpiece Material	B-3	1470
	C-4	1630
	A-3	1980
	B-4	2270
	A-4	3000

Adjust Laser Center Finder

Laser center finder is useful for drilling multiple holes with the same setting.

1. Using a small bit (1/16" or less), drill a hole in a scrap piece of wood the same thickness as your workpiece.
2. Turn on the laser and adjust the laser source, so the crosshair intersects the hole center. The laser is now adjusted for operation.

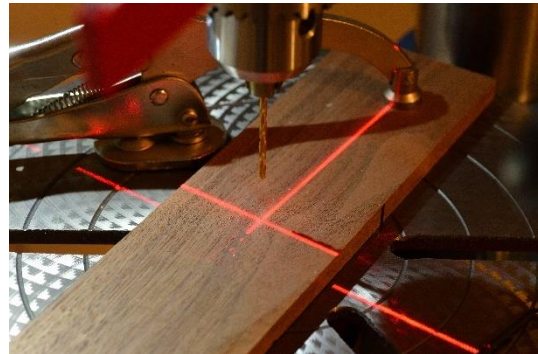

3. If you change the table height or thickness of your workpiece, readjust the center finder for the next set of holes.

WARNING

DO NOT stare into the laser beam or view it directly with an optical instrument. Laser can cause permanent and serious eye injury.

Lock the Chuck Guard

Before starting the drill press, cover the chuck with the chuck guard. Tighten the chuck guard lock set screw to secure the guard while drilling.



Drill Press Adjustments

Table Adjustments

These are the components for adjusting the position of the table:

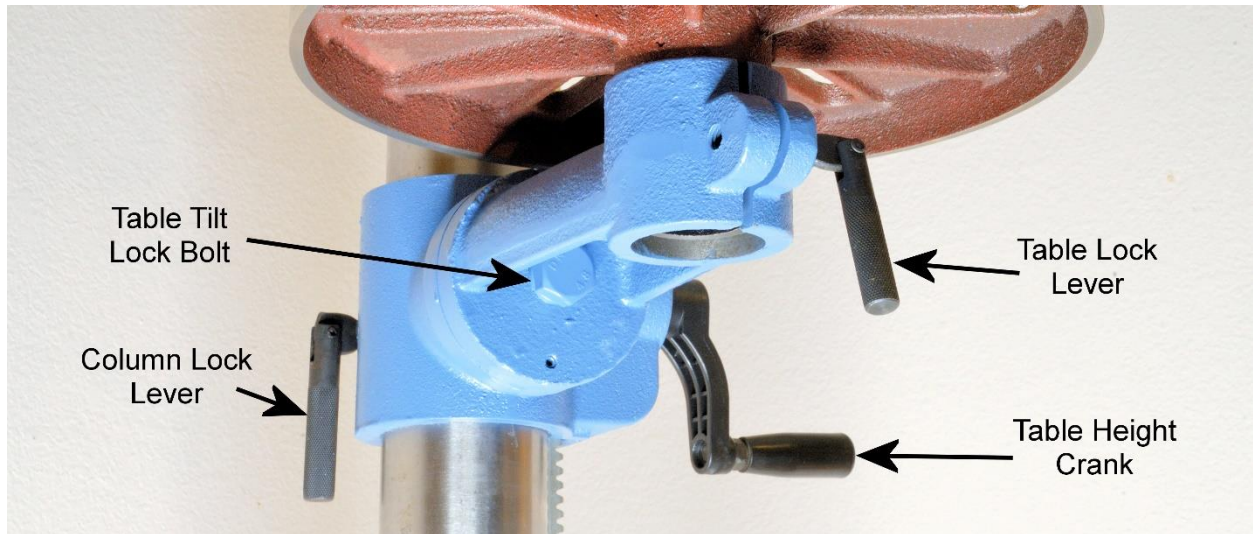

Table Height and Swing Position Adjustment

1. Loosen the column lock lever.
2. Use the table height crank to adjust the table's height.
3. Align the center hole in the table to the drill bit to avoid drilling into the table.
4. Tighten the column lock lever after adjustments.

Table Rotation Position Adjustment

1. Loosen the table lock lever.
2. Rotate the table to the desired position.
3. Tighten the table lock lever after adjustments.

Table Tilt Adjustment

1. Loosen table tilt lock bolt.
2. Adjust the table tilt angle using the tilt scale as shown in the picture below.

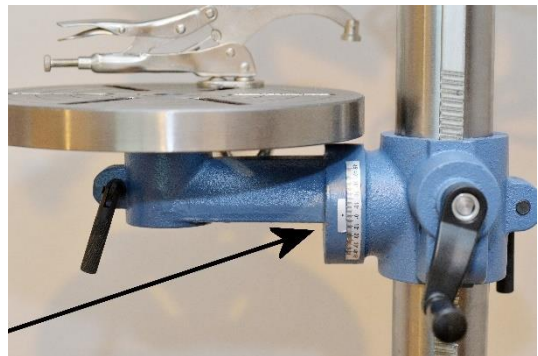

3. Tighten the table tilt lock bolt after adjustments.

Changing Drill Bits

To install a drill bit:

1. **Disconnect the drill press from the power source!!**
2. Open the chuck wide enough so it accepts the shank of the drill bit.
3. Insert the shank portion of the drill bit as far into the chuck as possible. Make sure the shank is centered between all three jaws and is **NOT** trapped in between the jaws as shown in this picture.

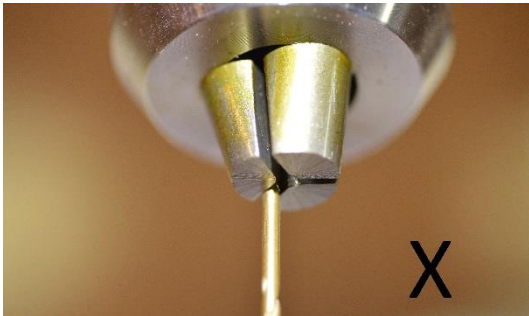

4. Also, make sure the chuck jaws are not grabbing the flute of the drill bit, as this may damage the drill bit and alter the alignment.
5. For drill bits with hexagon or three-flatted shank, be sure to align the jaws with the flat surfaces to maximize the grip.
6. Tighten the chuck by hand, then use the chuck key to tighten it further. There are three holes on the chuck for mounting the chuck key. Make use of all three holes to maximize the grip of the drill bit.



7. When finished, put away the chuck key and keep it in a safe spot.

To remove a drill bit:

1. **Disconnect the drill press from the power source!!**
2. **CAUTION:** The drill bit is sharp and can be hot after drilling. Keep your hands protected when retrieving the drill bit.
3. Use the chuck key to open the chuck and remove the drill bit.
4. When finished, put away the chuck key and keep it in a safe spot.

Changing Speed

1. **Disconnect the drill press from the power source!!**
2. Raise the belt cover and loosen the belt tension lock.



3. Refer to the speed chart for the desired speed and belt arrangement.

Oliver Machinery Model 10060.001 / 10061.001 12-Speed Drill Press		
		
Warning	Belt Position	Spindle RPM
Only Change Spindle Speeds With Machine Unplugged From Power	D-1	280
	C-1	430
	D-2	450
	B-1	580
Always Wear Safety Glasses and Clamp Workpiece at All Times	C-2	680
	D-3	700
	A-2	1300
	B-3	1470
Use Recommended Speed for Drill Bit Size and Workpiece Material	C-4	1630
	A-3	1980
	B-4	2270
	A-4	3000

4. Rearrange the belts to set the desired speed.
5. Push the motor away from the headstock to tension the belts.
6. Tighten the belt tension lock to keep the belt tensioned.
7. Recheck the belt tension. The belt should deflect less than 1/2" when gently pushing the belt midway between pulleys.
8. Close the belt cover after adjustments.

Adjust Depth Stop

1. Loosen the depth stop jam nut.
2. Lower the chuck until it reaches the desired drill depth. Hold the chuck in place.
3. Reposition the depth stop nut so it is pushing against the depth stop bracket.

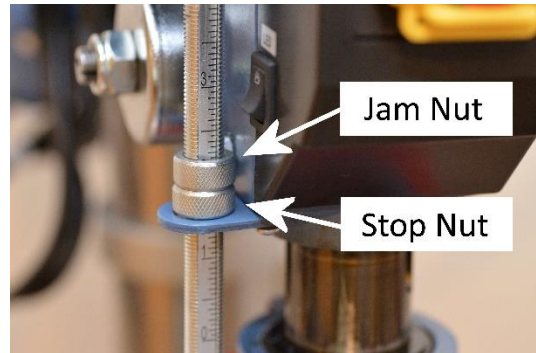

4. Lower the jam nut, so it pushes against the depth stop nut, then tighten the jam nut.

Changing Chuck

The chuck and the arbor can be swapped out for another chuck that has an MT-2 tapered arbor. It is recommended to have two people for this task.

1. **Disconnect the drill press from the power source!!**
2. Lower the chuck until the outer drift key slot is exposed on the side of the quill, then hold the quill in place.
3. Rotate the spindle until the inner drift key slot is also exposed and the arbor is visible.

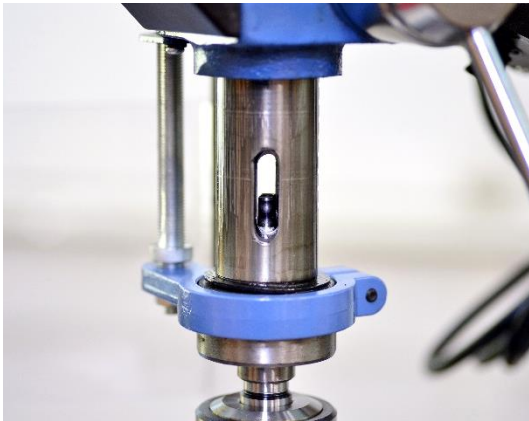

4. Insert the drift key into the slot, and tap the key with a rubber mallet until the arbor dislodges from the quill. Get some help to support the chuck to prevent damage.



5. Before installing a chuck, make sure the tapered surface of the arbor and the quill are clean.
6. Adjust the drill chuck so all chuck jaws are recessed into the body.
7. Insert the arbor into the quill. Rotate the chuck and push upward until the arbor and the quill are bound together.

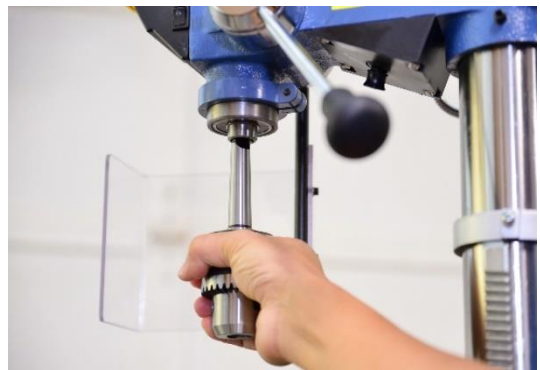

8. Place a block of wood on the table, then lower the spindle assembly with the feed handle to press the chuck against the woodblock. The chuck arbor should form a tight joint with the quill.



9. Attempt to detach the chuck by hand. If the chuck is detached, make sure the joint is clean, and repeat steps 7-8.

Drilling

Here are a few tips to prevent accidents and improve the quality of the drill holes.

Lubrication

When drilling non-wood materials, such as metal or plastic, use the correct type of lubricant to prevent overheating.

Feed Rate and Pressure

In most cases, it's best to keep the feed rate and pressure consistent when drilling a hole. The optimal feed rate and pressure depend on the drill bits and material types. Apply proper pressure and control the feed rate to avoid overheating. Overheating can dull the drill bit quickly and can cause the materials to catch fire. Replace a drill bit when it becomes dull, and do not force it to work.

Drilling Large Holes

When using very large drill bits, a dent made by a center punch may not keep the drill bit from wandering. Drilling a pilot hole can mitigate this issue.

Dust/Debris Removal

When drilling deep or big holes, raise the drill bit often to clear the debris. Doing so can reduce friction and extend the life of the drill bit and the motor.

Dust produced by drilling is a health hazard. Using a dust collector to remove the dust and debris to reduce health risks. Wear a good dust mask to further reduce dust inhaled.

Stopping the Drill Bit

NEVER use your hand or any external objects to stop the spinning drill bit. Allow the drill press to slow down to a complete stop before removing the workpiece and the drill bit.



A drill press is only designed for downward cutting. Never use the drill press like a mill. Performing sideways cutting with milling bits can damage the drill press and cause the chuck to dislodge from the drill press.

Accessories

Oliver Machinery has a collection of accessories and spare parts for maintenance needs. Please visit our website **OLIVERMACHINERY.NET** to purchase these items.

You may also call 1-800-559-5065 or email PARTS@OLIVERMACHINERY.NET to place an order. We are available Monday through Friday, 7:30 AM - 4 PM Pacific Time.

Touchup Paint



Keeping all painted surfaces in good condition keeps your machine looks nice and rust-free. We have pre-mixed spray paint available in Oliver-Blue for purchase.

Maintenance

Routine maintenance keeps your drill press in top shape. Please follow the maintenance schedule below, and use the maintenance record worksheet in this manual to document all tasks completed.

NOTICE: Maintenance schedule may vary for individual users due to different situations and safety requirements.

 WARNING	Disconnect the machine from the power source before any maintenance work is performed. After servicing the drill press, remove all wrenches and tools before restarting the machine. Failure to comply can cause serious injury!
---	---

Maintenance Schedule

Interval	Task
Every day	Inspect the power cord for signs of aging and damage before starting the machine. Replace worn parts as needed.
	Inspect drill bits before use. Replace damaged and dull drill bits.
Every Month	Apply rust protectant on unpainted cast iron surfaces.
	Check V-belt tension and inspect the belt for signs of wear and damage.
	Lubricate column, quill, and spindle.

Notice: Motor and spindle bearings are permanently sealed and lubricated. They do not require lubrication.

Troubleshooting

Mechanical / Electrical Issues

Problem	Possible Cause	Possible Solution
Machine does not start.	Machine is not connected to a power source.	<ol style="list-style-type: none"> 1. Make sure the machine is plugged in or the power disconnect is at the ON position. 2. Ensure all electrical connections have good contacts.
	Low voltage/current.	Check/repair the power circuit by a licensed electrician.
	Faulty switch/motor/capacitor.	Contact customer service for further assistance.
	Tripped circuit breaker or blown fuse.	Reconnect the circuit and see the troubleshooting steps "Tripped circuit breaker or blown fuse."
Tripped circuit breaker or blown fuse	Machine is undersized for the operation.	Reduce feed rate/pressure and use a sharp drill bit. Remove drilling debris more frequently.
	Dull drill bit	Replace or sharpen the drill bit.
	Too much load on a circuit.	Make sure the power circuit is sized for this machine. If the circuit is shared, ensure it is sized to supply power for all items in the circuit.
	Motor/capacitor issue.	Contact customer service for further assistance.
Machine vibrates excessively or makes unexpected noise.	Damaged/unbalanced drill bit.	Replace any damaged/unbalanced drill bits. Make sure the drill bit is installed correctly. The shank must be centered between the three chuck jaws.
	Machine stands on an uneven floor.	Reposition the machine on a flat, level surface.
	V-belt worn, slipping, or hitting belt cover.	Clean belt and pulleys. Adjust belt tension. Replace V-belt if it shows signs of aging.
	Unbalanced chuck.	Remount chuck. Make sure the contact surface between the arbor and the quill is free of debris. Replace damaged chuck and arbor.
	Loose components.	Tighten the fasteners of the component.
	Worn bearings.	Contact customer service for assistance.

Problem	Possible Cause	Possible Solution
Machine stalls during operation.	Incorrect spindle speed.	Adjust drive belts to reduce spindle speed.
	Machine is undersized for the operation.	Reduce feed rate/pressure and use a sharp drill bit. Remove drilling debris more frequently.
	Dull drill bit.	Replace or sharpen the drill bit.
	Belt slipping.	Clean belt and pulleys. Adjust belt tension.
	Motor/capacitor issue.	Contact customer service for further assistance.
Drill bit is slipping inside the chuck.	Drill bit is not installed correctly.	Insert the shank portion of the drill bit as far into the chuck as possible. Use the chuck key and all three holes on the chuck to tighten the drill bit.
Spindle does not lower to the lowest position.	Depth stop is set.	Raise the stop bolt above the 3-3/8" mark on the depth stop gauge.
Table is stuck or difficult to adjust.	Table is locked.	Loosen the locking handle before adjusting the table. To tilt the table, make sure the centering set screw is backed out.
	Dirty rack and pinion.	Clean and lightly lubricate the rack.
Laser center finder does not aim correctly.	Table height changed, or workpiece thickness changed.	Readjust the center finder.

Operation / Quality-Related Issues

Problem	Possible Cause	Possible Solution
Workpiece dislodged during operation.	Workpiece is not securely mounted on the table.	NEVER hold the workpiece by hand. Use a drill vise or T-Slot clamps to hold the workpiece on the table. Make sure the clamping tool is securely mounted on the table.
Spindle becomes very hot.	Drill bit is operating at high speed/high load for an extended period.	Allow the drill bit and motor to cool down. Reduce feed rate and feed pressure. Use sharp drill bits.
Poor finish.	Dull drill bit.	Replace/sharpen the drill bit.
	Feed rate is too high.	Reduce feed rate.
	Exit hole is not properly supported.	Support the workpiece with a backer board.
	Workpiece overheated.	Lower feed rate and feed pressure. Use proper lubrication when drilling metals and plastic to cool down the workpiece.

Wiring Diagram

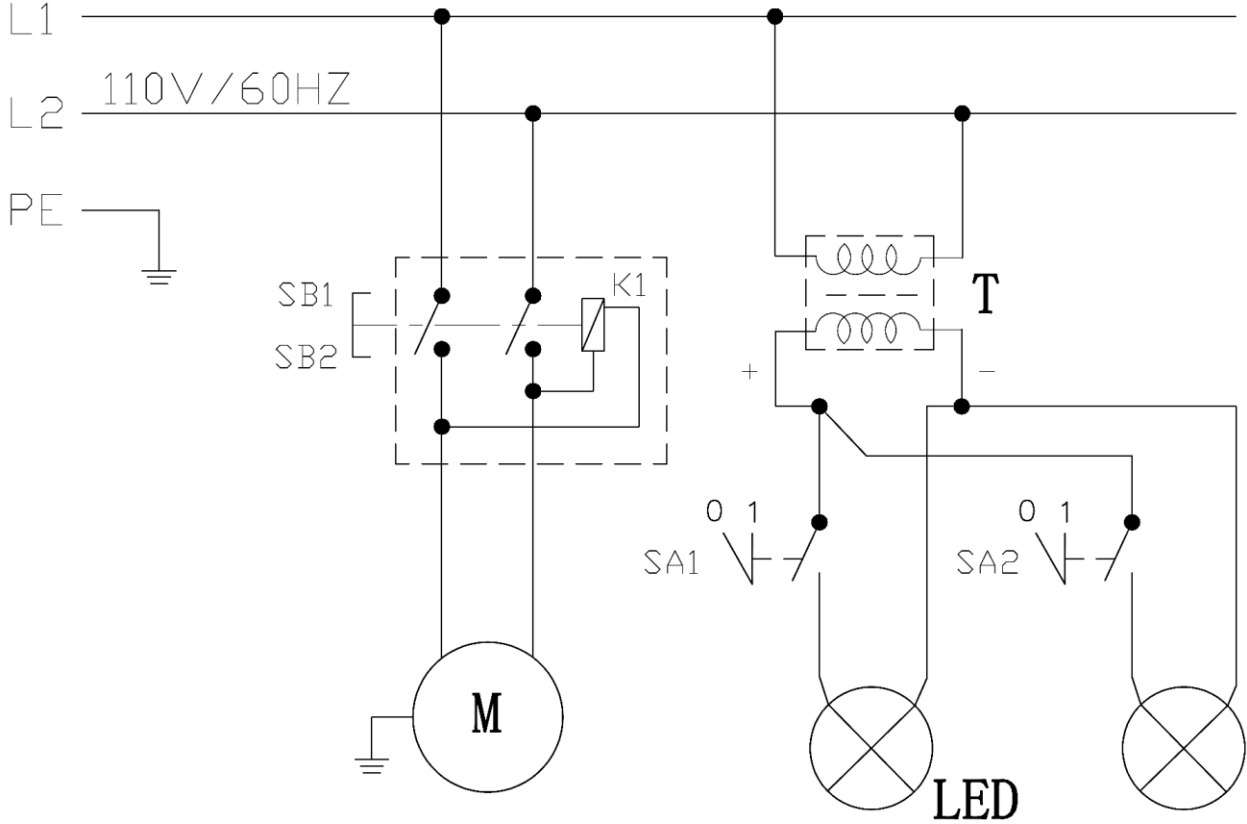

Parts List

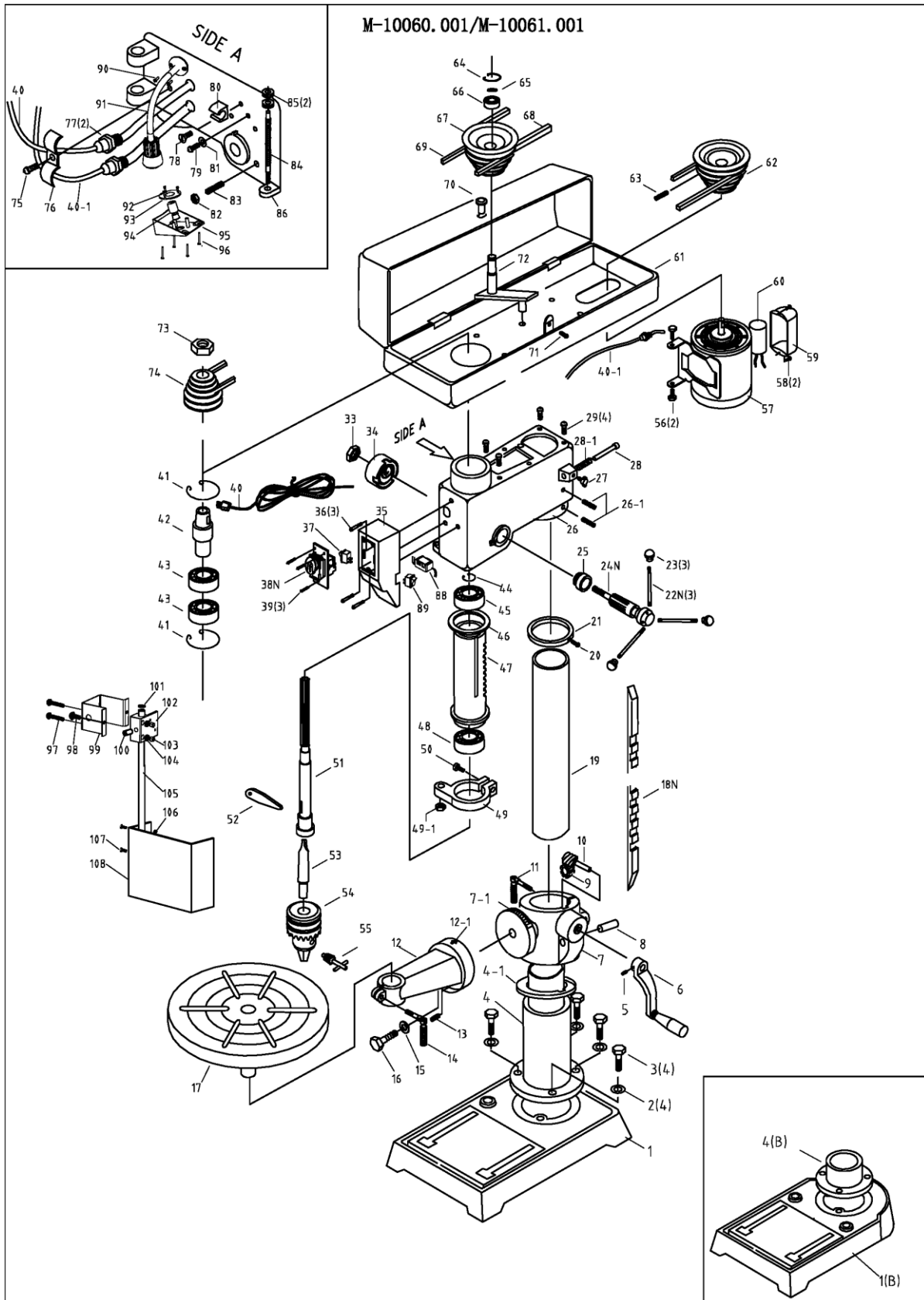

Key	Part Number	Descriptions	QTY
1	10061-1	BASE FLOOR MODEL	1
1B	10060-1	BASE BENCH MODEL	1
2	10061-2	WASHER	4
3	10061-3	BOLT FLOOR MODEL	4
3	10060-3	BOLT BENCH MODEL	4
4	10061-4	BASE FLANGE FLOOR MODEL	1
4-1	10061-4-1	FRICTION RING	1
4B	10060-4	BASE FLANGE BENCH MODEL	1
5	10061-5	SCREW	1
6	10061-6	TABLE CRANK HANDLE	1
7	10061-7	TABLE BRACKET w/scale	1
7-1	10061-7-1	TILT SCALE ONLY w/rivets	1
8	10061-8	HELICAL GEAR SHAFT	1
9	10061-9	HELICAL GEAR	1
10	10061-10	ELEVATING WORM GEAR	1
11	10061-11	CLAMP LEVER	1
12	10061-12	TABLE ARM BRACKET Includes 12-1	1
13	10061-13	CENTERING SET PIN	1
14	10061-14	CLAMP LEVER	1
15	10061-15	WASHER	1
16	10061-16	BOLT	1
17	10061-17	TABLE	1
18N	10061-18N	RACK FLOOR MODEL	1
18N	10060-18N	RACK BENCH MODEL	1
19	10061-19	COLUMN FLOOR MODEL	1
19	10060-19	COLUMN BENCH MODEL	1
20	10061-20	SCREW	1
21	10061-21	RACK COLLAR	1
22N	10061-22N	FEED HANDLE	3
23	10061-23	HANDLE KNOB	3
24N	10061-24N	FEED PINION SHAFT	1
25	10061-25	SLEEVE	1
26	10061-26	HEADSTOCK CASTING	1
26-1	10061-26-1	SET SCREW	2
27	10061-27	LOCK SCREW	1
28	10061-28	BELT TENSION ADJUSTING ROD	1
28-1	10061-28-1	SPRING	1
29	10061-29	SCREW	4
33	10061-33	NUT	1

Key	Part Number	Descriptions	QTY
34	10061-34	RETURN SPRING & HOLDER	1
35N	10061-35	SWITCH BOX	1
36	10061-36	SCREW	3
37	10061-37	LIGHT SWITCH	1
38N	10061-38N	ON/OFF SWITCH	1
39	10061-39	SCREW	3
40	10061-40	POWER CORD w/MOLDED PLUG	1
40-1	10061-40-1	MOTOR TO SWITCH CORD	1
41	10061-41	SNAP RING	2
42	10061-42	DRIVER INSERT	1
43	BB-6203	6203 BALL BEARING	2
44	10061-44	SNAP RING	1
45	BB-6201	6201 BALL BEARING	1
46	10061-46	QUILL GASKET	1
47	10061-47	QUILL	1
48	BB-6204	6204 BALL BEARING	1
49	10061-49	DEPTH STOP BRACKET	1
49-1	10061-49-1	NUT	1
50	10061-50	BOLT	1
51	10061-51	SPINDLE	1
52	10061-52	DRIFT KEY	1
53	10061-53	ARBOR MT-2/JT-3	1
54	10061-54	5/8" CHUCK w/KEY JT-3	1
55	10061-55	CHUCK KEY ONLY	1
56	10061-56	BOLT	2
57	10061-57	1/2HP MOTOR 115V 1Ph	1
58	10061-58	SCREW	2
59	10061-59	CAPACITOR COVER	1
60	10061-60	CAPACITOR	1
61	10061-61	PULLEY COVER	1
62	10061-62	MOTOR PULLEY	1
63	10061-63	SET SCREW	1
64	10061-64	SNAP RING	1
65	10061-65	SNAP RING	1
66	BB-6202	6202 BALL BEARING	1
67	10061-67	IDLER PULLEY	1
68	10061-68	M22 V-BELT	1
69	10061-69	M22 V-BELT	1
70	10061-70	KNOB	1
71	10061-71	SCREW	1

Key	Part Number	Descriptions	QTY
72	10061-72	IDLER PULLEY HOLDER	1
73	10061-73	NUT	1
74	10061-74	SPINDLE PULLEY	1
75	10061-75	SCREW	1
76	10061-76	CORD CLAMP	1
77	10061-77	GROMMET	2
78	10061-78	SCREW	1
79	10061-79	SCREW	1
80	10061-80	KEY HOLDER	1
81	10061-81	WASHER	1
82	10061-82	NUT	1
83	10061-83	SET SCREW	1
84	10061-84	DEPTH STOP ROD	1
85	10061-85	DEPTH STOP LOCK NUT	2
86	10061-86	DEPTH STOP SUPPORT	1
88	10061-88	LASER TRANSFORMER	1
89	10061-89	LASER SWITCH	1
90	10061-90	SCREW	2
91	10061-91	LED LIGHT	1
92	10061-92	SCREW	3
93	10061-93	LASER COVER	1
94	10061-94	KNOB	1
95	10061-95	LASER BOX	1
96	10061-96	SCREW	4
97	10061-97	SCREW	2
98	10061-98	SCREW	1
99	10061-99	SWITCH PLATE	1
100	10061-100	SET SCREW	1
101	10061-101	SHAFT CLIP RING	1
102	10061-102	SWITCH PLATE	1
103	10061-103	NUT	2
104	10061-104	SPRING WASHER	2
105	10061-105	FIXED SEAT CONNECT BAR	1
106	10061-106	NUT	2
107	10061-107	SCREW	2
108	10061-108	CHUCK GUARD	1

Maintenance Record

Date	Task	Operator

Warranty and Service

Oliver Machinery makes every effort to assure that its equipment meets the highest possible standards of quality and durability. All products sold by Oliver Machinery are warranted to the original customer to be free from defects for a period of two (2) years on all parts excluding electronics and motors which are warranted for one (1) year from the date of shipment. Oliver Machinery's obligation under this warranty shall be exclusively limited to repairing or replacing products or parts or components, at its sole option, determined by Oliver Machinery to be defective. Oliver Machinery shall not be required to provide other form of indemnity or compensation including but not limited to compensatory damages.

This warranty does not apply to defects due to direct or indirect misuse, abuse, negligence, accidents, unauthorized repairs, alternation outside our facilities, lack of maintenance, acts of nature, or items that would normally be consumed or require replacement due to normal wear and tear.

OTHER TERMS

To obtain and exercise the warranty right, please call 800-559-5065 or fill out warranty request form online at www.olivermachinery.net.

Warranty parts are shipped via Parcel or Ground. Additional charges will occur and charge to customers if express shipping is required.

DISCLAIMER

Under no circumstances shall Oliver Machinery be liable for death, personal or property injury, or damages arising from the use of its products.

Oliver Machinery reserves the right to make changes without prior notice to its products to improve function or performance or design.

FOR MORE INFORMATION

If you need assistance or have questions beyond what is covered in the scope of this warranty information, please call 800-559-5065 or email us at info@olivermachinery.net.

Appendix

US Standard – Metric Conversion Chart

Fractional In.	Decimal In.	Millimeters	Fractional In.	Decimals In.	Millimeters
1/64	.0156	.396	33/64	.5156	13.096
1/32	.0312	.793	17/32	.5312	13.493
3/64	.0469	1.190	35/64	.5469	13.890
1/16	.0625	1.587	9/16	.5625	14.287
5/64	.0781	1.984	37/64	.5781	14.684
3/32	.0937	2.381	19/32	.5937	15.081
7/64	.1094	2.778	39/64	.6094	15.478
1/8	.125	3.175	5/8	.625	15.875
9/64	.1406	3.571	41/64	.6406	16.271
5/32	.1562	3.968	21/32	.6562	16.668
11/64	.1719	4.365	43/64	.6719	17.065
3/16	.1875	4.762	11/16	.6875	17.462
13/64	.2031	5.159	45/64	.7031	17.859
7/32	.2187	5.556	23/32	.7187	18.256
15/64	.2344	5.953	47/64	.7344	18.653
1/4	.25	6.350	3/4	.75	19.050
17/64	.2656	6.746	49/64	.7656	19.446
9/32	.2812	7.143	25/32	.7812	19.843
19/64	.2969	7.540	51/64	.7969	20.240
5/16	.3125	7.937	13/16	.8125	20.637
21/64	.3281	8.334	53/64	.8281	21.034
11/32	.3437	8.731	27/32	.8437	21.431
23/64	.3594	9.128	55/64	.8594	21.828
3/8	.375	9.525	7/8	.875	22.225
25/64	.3906	9.921	57/64	.8906	22.621
13/32	.4062	10.318	29/32	.9062	23.018
27/64	.4219	10.715	59/64	.9219	23.415
7/16	.4375	11.112	15/16	.9375	23.812
29/64	.4531	11.509	61/64	.9531	24.209
15/32	.4687	11.906	31/32	.9687	24.606
31/64	.4844	12.303	63/64	.9844	25.003
1/2	.5	12.700	1.0	1.	25.400



Oliver Machinery is always adding new Industrial Woodworking products to the line.

For complete, up-to-date product information, visit us online at:

WWW.OLIVERMACHINERY.NET

or call toll free 1-800-559-5065

**** SAVE THIS MANUAL FOR FUTURE REFERENCE. ****