

SLIDING TABLE SAW

OPERATING MANUAL



- Before you use the machine, please carefully read the manual and obey all related notes for safety and instructions.
- This manual is a part of the machine, so please make sure to include this manual when the machine is moved, transferred and sold.

PLEASE CAREFULLY READ THIS OPERATING MANUAL BEFORE USE

Thank you very much for your purchasing our SCORING TABLE SAW.

For personal safety and excellent performance of the machine, please first carefully read the Operating Manual and other attachments to be familiar with the machine's functions, safe instructions and notes.

Noise range

The figures quoted are emission levels and are not necessarily safe working levels. Whilst there is a correlation between the emission and exposure levels, this cannot be used reliably to determine whether or not further precautions are required. Factors that influence the actual level of exposure of the workforce include characteristics of the work room, the other sources of noise, etc. i.e. the number of machines and other adjacent processes.

Also the permissible exposure level can vary from country to country, this information; however, will enable the user of the machine to make a better evaluation of the hazard and risk.

If the environmental noise level exceeds the permissible value, the customer is requested to adopt addition noise control measures.

Noise level :

According to EN1870-1/ISO3746 (The uncertainty K = 4 dB)

Sound pressure level: 78dB(A)

From the above measured results, this sliding table sawing machine present a little hearing or noise hazard to operator, the operator is required to wear ear caps whenever possible during operation and conform to the local safety regulations of labors.



- NOTES
1. The contents in this Operating Manual may be changed without pre-notice Sorry.
 2. The contents in this Operating Manual have been carefully noted. In case there is a mistake that directly or indirectly results in damage, sorry our company will not be responsible for it.
 3. This Operating Manual is a part of the machine, so please make sure to include it when the machine is moved, transferred and sold.
-

SAFE INSTRUCTIONS

1. If you are not fully familiar with the machine's operation, you must be instructed by your supervisor or qualified person.
2. If the running direction of the saw is wrong, it will cause danger.
3. The anti-skid floor cushion is put at the operator's standing area and the machine's working area. There should be a proper working space around the machine.
4. When the saw doesn't completely stop, please don't use extra pressure to stop it.
5. Don't operate the machine until the saw guard is well installed.
6. Please wear the approved safety glasses to protect eyes.
7. Before you repair or maintain the machine or change saw, please first shut down the machine's power.
8. When you rip small work piece (<120mm), please use the push stick or wood block.
9. When the saw hasn't completely stopped, please don't adjust the saw guard.
10. When power is ON, don't clean saw and don't use hands to clean sawdust and use brush to clean chips.
11. Confirm if the machine is well installed with the earth wire.
12. When you finish the job or operator leave the working area, please make sure to turn the power to OFF.
13. While working, don't fail to pay full attention. Looking around, talking and clamoring are careless behaviors and will incur serious injury.
14. While operating the machine, please keep stable, balanced and coordinated gesture. Operator and others can't stand at the same line with the saw or the work piece.
15. While the machine is running, no matter if the guard is installed, don't go near the saw or attach yourself to the machine.
16. The weight of work piece can't exceed 70kgs.
17. Before you replace parts, maintain or repair the machine, please first shut down the machine's power.
18. Only tools made in conformity to EN 847-1 : 1997 shall be used on the machine.
19. It should have enough lights and lighting around the machine's place location.
20. Machine use for cutting for small amount or quantity and various working piece, it may cut the wood, aluminum, imitation marble...non metal material. Prohibit to cutting the steel metal stuffs.



EXPLANTION OF WARNING SIGN

To secure safety

Please make sure to carefully read the safe instructions to be familiar with the machine's functions, safe information and notes before you start, run & start the machine.

Please carefully read the trouble-shooting guide to be familiar with the machine's functions, safe information and notes before you repair or check the breakdown.

If you wrongly operate the machine, different degrees of personal injury or damage may happen. So, to avoid such wrong operation, we list the following 3 classes of warning signs:

WARNING SIGN	WARNING CLASS	WARNING CONTENTS
 DANGER	DANGER	If you wrongly operate it, assume the user to be dead or seriously injured with high danger.
 WARNING	WARNING	If you wrongly operate it, assume the user to be dead or seriously injured.
	NOTE	Remind the user to surely close power.

It's listed as “ **CAUTION** ”, but the related serious damages may happen as per different situations.

The definition of “ seriously injured ”, “ lightly injured “, “ property damaged “ shown in the above contents is as follows :

Seriously injured : Because of becoming blind, injury, electric shock, bone fracture, there is an after-effect that requires to stay hospital or go to hospital for treatment for a long time.

Lightly injured : Don't need to stay hospital or go to hospital for treatment for a long time.

Property damaged : Property and machine are directly or indirectly damaged.

CATALOG

SAFE INSTRUCTIONS	1
EXPLANATION OF WARNING SIGN	2
1. BRIEF INTRODUCTION TO MACHINE	
1-1 SPECIFICATION	1-1
1-2 MACHINE DIMENSION	1-1
1-3 FEATURES	1-2
1-4 INDICATION	1-3
1-5 RIVING KNIFE SPECIFICATION	1-4
1-6 MACHINE NOISE	1-5
2. SPARE PARTS ASSEMBLY UNIT	
2-1 TRANSPORT	2-1
2-2 SLIDING TABLE UNIT	2-3
2-3 CROSSCUT TABLE UNIT	2-5
2-4 CROSSCUT FENCE UNIT	2-6
2-5 RIP FENCE UNIT	2-7
2-6 EXTENSION TABLE	2-8
2-7 DUST GUARD UNIT	2-10
2-8 MITER FENCE UNIT	2-14
2-9 RIVING KNIFE UNIT	2-15
2-10 MAIN SAW UNIT	2-16
2-11 SCORING SAW UNIT	2-19
3. OPERATING UNIT	
3-1 POWER CONNECTION	3-1
3-2 OPERATION OF CONTROL PANEL	3-3
3-3 PRESENT SIZE CORRECTION	3-4
3-4 PARAMETER SETTING	3-5
4. CLEAN & MAINTAIN UNIT	
4-1 MAINTENANCE OF THE SLIDING TABLE	4-1
4-2 MAINTENANCE OF ANGLE SLIDE RAIL	4-1
4-3 SAFETY CHECK 【CE】	4-2
5. TROUBLE SHOOTING GUIDE	5-1
6. 3D SYSTEM DRAWING	
6-1 BODY UNIT	
MACHINE BODY	6-1
SUPPORTING ROCKER ARM	6-3
ROTARY BASE	6-4
6-2 SAW BLADE UNIT	
MAIN SAW	6-6
MAIN SAW ELEVATOR AND TILT	6-8
SCORING SAW	6-10
6-3 MOTOR UNIT	
MAIN SAW MOTOR	6-12
SCORING SAW MOTOR	6-13

6-4 TABLE UNIT	
MAIN TABLE	6-14
SLIDING TABLE	6-15
CROSSCUT TABLE	6-18
EXTENSION TABLE	6-19
6-5 FENCE UNIT	
RIP FENCE	6-20
RIP FENCE DIGITAL DISPLAY	6-22
CROSSCUT FENCE	6-24
CROSSCUT FENCE DIGITAL DISPLAY	6-26
MITER FENCE	6-29
6-6 SAFETY GUARD UNIT	
SIMPLE TYPE SAW GUARD	6-30
DUST-COLLECTING FASTENING RACK	6-31
SAFETY GUARD CONNECTING ARM	6-32
LUX SAW GUARD	6-33
6-7 OPTION ACCESSORIES UNIT	
RAPID CLAMP BASE	6-35
AUXILIARY CROSSCUT CARRIAGE	6-36
PNEUMATIC CLAMP	6-38

7. CIRCUIT DIAGRAM UNIT

7-1 CIRCUIT DIAGRAM	7-1
7-2 CONTROL DIAGRAM	7-2

1. BRIEF INTRODUCTION TO MACHINE ▶▶▶

1-1 SPECIFICATION

Technical data , Standard and optional equipment

Unit : mm

ITEM	MODEL	P-19	P-26	P-32
Rectified cast iron fixed table dimension		570 × 1000	570 × 1000	570 × 1000
Sliding table dimension		380 × 1900	380 × 2600	380 × 2600
Main saw blade Ø305 (12")		●	●	●
Main saw blade Ø355 (14") / Max.		✓	✓	✓
Main saw bore		Ø 30 (Ø 25.4)	Ø 30 (Ø 25.4)	Ø 30 (Ø 25.4)
Max. cutting height with bade at 90°		105	105	105
Max. cutting height with bade at 45°		73	73	73
Main motor power 5hp (3.7kw)		●	●	●
Main motor power 7.5hp (5.5kw)		✓	✓	✓
Main blade speed		3000 / 4000 / 5000 RPM	3000 / 4000 / 5000 RPM	3000 / 4000 / 5000 RPM
Scoring swa blade Ø120		●	●	●
Scoring swa blade bore		Ø 22	Ø 22	Ø 22
Scoring motor power 1hp (0.75kw)		●	●	●
Scoring blade speed 8000 rpm		●	●	●
Cutting width 1000mm		●	●	●
Cutting width 1300mm		✓	✓	✓
Cutting width 1500mm		✓	✓	✓
Cutting width adjustment		Manual	Manual	Manual
Saw table extension 370 mm		●	●	●
Saw table extension 720 mm (CE)		✓	✓	✓
Blade titing adjustment		Manual (0° ~ 45°)	Manual (0° ~ 45°)	Manual (0° ~ 45°)
Main saw height adjustment		Manual	Manual	Manual
Scoring saw height adjustment		Manual	Manual	Manual
Scoring saw +/- direction adjustment		Manual	Manual	Manual
Blade titing angle show		Simple / Digital display	Simple / Digital display	Simple / Digital display
Main blade speed show		LED exhibit	LED exhibit	LED exhibit
Overhead saw guard		Simple / Luxurious	Simple / Luxurious	Simple / Luxurious
Crosscut fence digital display		✓	✓	✓
Rip fence digital display		✓	✓	✓
Rapid clamp		✓	✓	✓
Tool frame		✓	✓	✓
Noise level		78dB	78dB	78dB
Dust coliection system		Main channel 4" , Simple guard Ø 60 , Luxurious 3"		

● = Standard ✓ = Additional extras

1-2 MACHINE DIMENSION

Space requirements

	P-19	P-26	P-32
A	1900	2600	3200
B	850 mm (1200 mm for CE)		
C	1000	1300	1500
D	1225	1525	1725
E	1520	1820	1820
F	max.2930	max.3230	max.3230
G	2235	2935	3525
H	2155	2885	3470

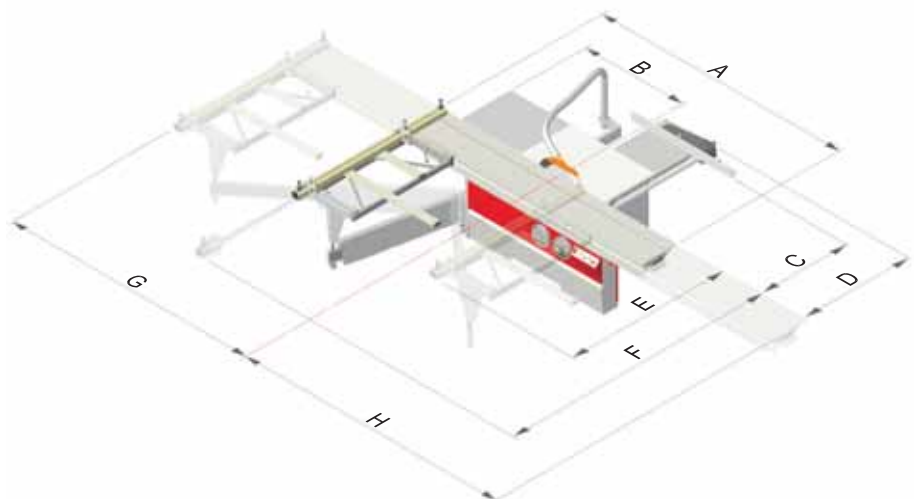

Cutting depths

Saw blade diameter	φ 255(10")	φ 305(12")	φ 355(14")
Cutting depths at 90°	0~55 mm (0~2.16 in)	0~80 mm (0~3.15 in)	0~105 mm (0~4.13 in)
Cutting depths at 45°	0~38 mm (0~1.5 in)	0~56 mm (0~2.2 in)	0~73 mm (0~2.87 in)

Cutting depths

Sliding table cutting lengths	With or without scoring saw blade
1900 mm (74.8 in)	1800 mm (70.87 in)
2600 mm (102.36 in)	2500 mm (98.53 in)
3200 mm (126 in)	3100 mm (122.05 in)

Machine weight

Model	P-19	P-26		P-32		
Cutting width	1000 mm	1000 mm	1300 mm	1000 mm	1300 mm	1500 mm
Main crate N / W	720 / 770	740 / 790	750 / 800	760 / 810	770 / 820	780 / 830
Sliding table length	Length		1900 mm	2600 mm	3200 mm	
	N / W		103 / 153	157 / 217	187 / 247	

1-3 FEATURES

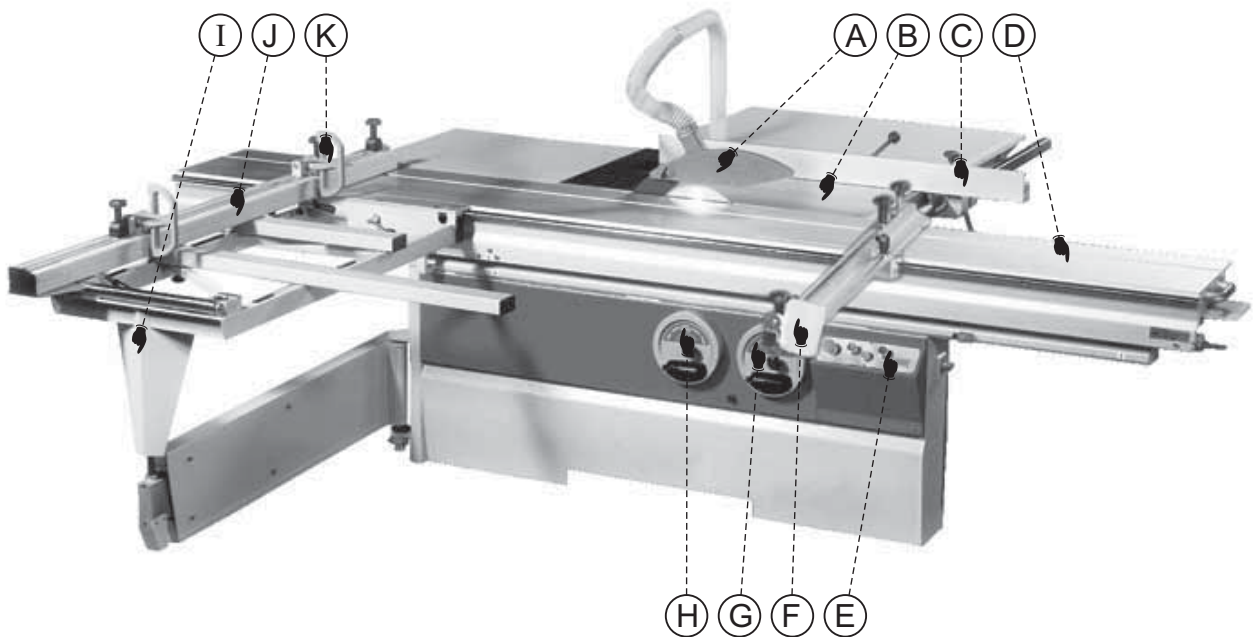

- A : Dust guard** ----- Not only reduce dust produced by chips while cutting, but also warning the operator where the saw-blade position.
- B : Main table** ----- Main working table.
- C : Rip fence** ----- Reference positioning while ripping.
- D : Sliding table** ----- Table for main feeding while cutting.
- E : Controlling panel** ----- Control the machine's running, indication, stop etc.
- F : Miter fence** ----- Reference positioning while 0~45° cutting.
- G : Main saw tilting adjusting hand wheel** ----- Hand wheel for adjusting main saw tilting 0~45°.
- H : Main saw lifting adjusting hand wheel** ----- Hand wheel for adjusting main saw up/down.
- I : Cross cut table** ----- Used to put the workpiece while cross cutting.
- J : Cross cut fence** ----- To position the size of the movable positioning board.
- K : Movable positioning stops** ----- To position while cross cutting.

1-4 INDICATION

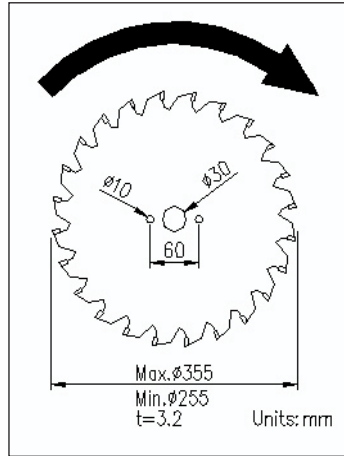

Fig.1

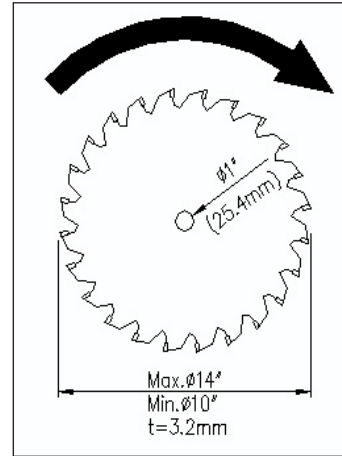

Fig.2

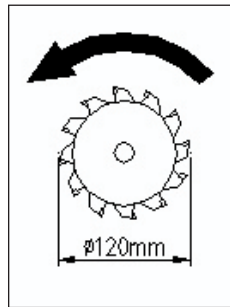

Fig.3

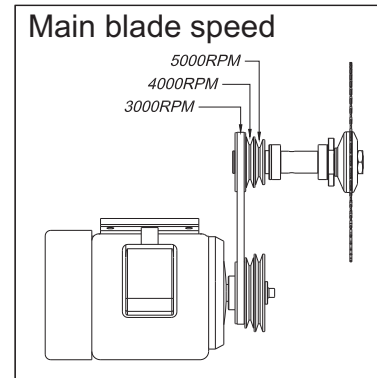

Fig.4

Note

Fig.1 : the main saw's size and running direction.

Fig.2 : the main saw's size and running direction.

Fig.3 : the scoring saw's size and running direction.

Fig.4 : Belt speed diagram.

1-5 RIVING KNIFE SPECIFICATION

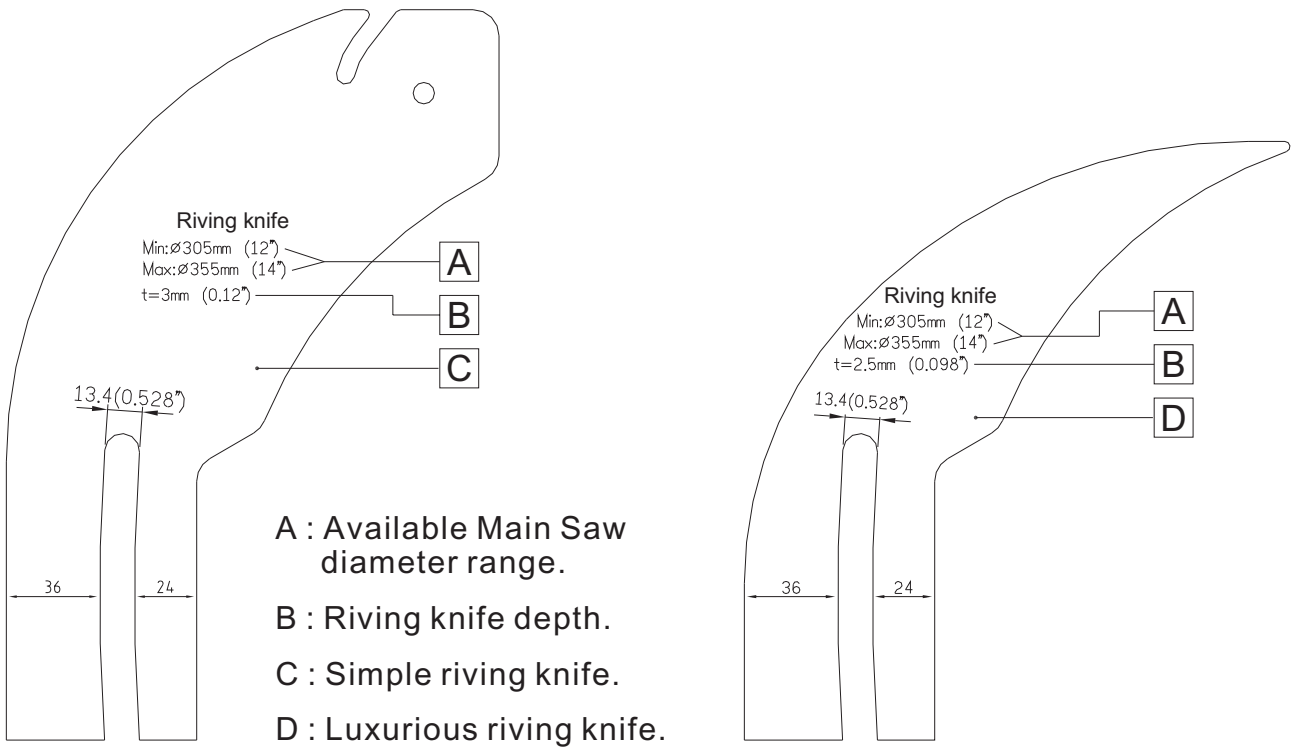

⚠ WARNING

Prior to setting the riving knife, check whether it matches the saw blade diameter and body thickness.
 Always switch off the main switch prior to setting the riving knife preventing cause danger.

The machine is delivered as standard with the following riving knives.
 305~355 / 2.5 specification : Saw blade diameter 305~355mm.
 Saw blade basic body thickness up to maximum : 2.5mm.
 Diameter range and thickness are both engraved at the bottom end of the riving knife.

The thickness of the riving knife was selected so that they match the commercially available saw blade thickness in the respective diameter range. Use correct riving knife only and always.

2-1 TRANSPORT

TRANSPORT WOODEN CRATE

⚠ WARNING

To transport the machine, please request the person who has licenses of gantry, crane, lift truck, etc, to operate. The weight of machine is listed in the chapter 2-1 and 2-2. After confirming, please proceed as per the weight. To suspend and move the machine, please follow Notes of Chapter 2-1 and 2-2 to operate. During transport, if the machine collapses or drops, it will cause an accident. While transporting or assembling, please don't damage the wiring. After assembly is completed, please execute protective measures to avoid the workers, other persons or lift truck damaging the wiring.

The machine's gross weight is about :

Body box(Cutting width 1m) : 810kgs

Body box(Cutting width 1.3m) : 820kgs

Body box(Cutting width 1.5m) : 830kgs

Please refer to Chapter 1-2 for detailed data.

1. USE CRANE TO MOVE WOODEN CRATE

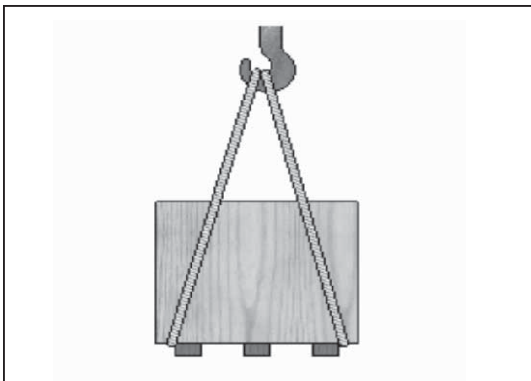

⚠ WARNING

The crane's rope must be able to bear the machine's gross weight to prevent its breaking from happening danger.

2. USE LIFT TRUCK TO MOVE WODEN CRATE

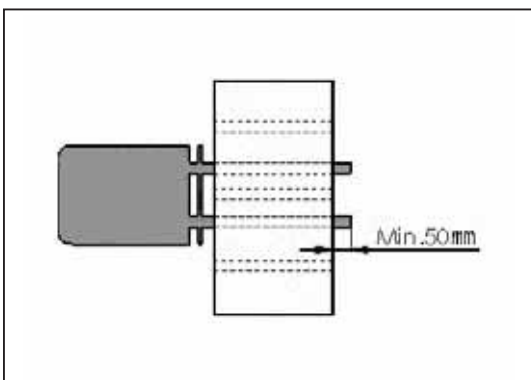

⚠ WARNING

Please put the wooden crate in the middle of the forks and keep over 50mm distance between the front of the forks and the wooden crate to avoid the case collapsing and secure safe transport.

TRANSPORT MACHINE

The machine's net weight is about :

Body (Cutting width 1m) : 760kgs

Body (Cutting width 1.3m) : 770kgs

Body (Cutting width 1.5m) : 780kgs

Please refer to Chapter 1-2 for detailed data.

1. USE LIFT TRUCK TO TRANSPORT MACHINE

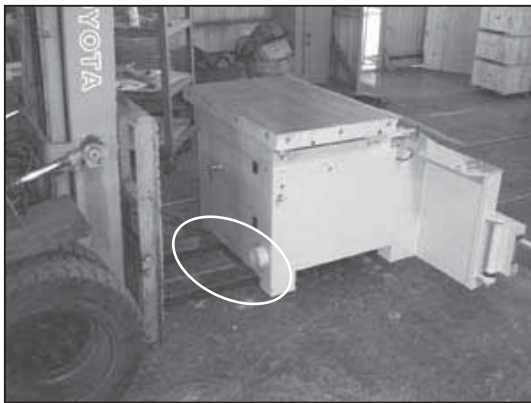

WARNING

- The lift truck must be able to bear to least 5tons.
- Make sure the machine is balanced. While transporting, please don't vibrate it and keep at least 2m safe distance away from the transport area.
- The machine is equipped with the slots as shown in left Fig. that are specially designed for transport of lift truck and manual (electric) trolley.

2. USE GANTRY OR CRANE TO MOVE MACHINE AWAY PALLET



Fig.1

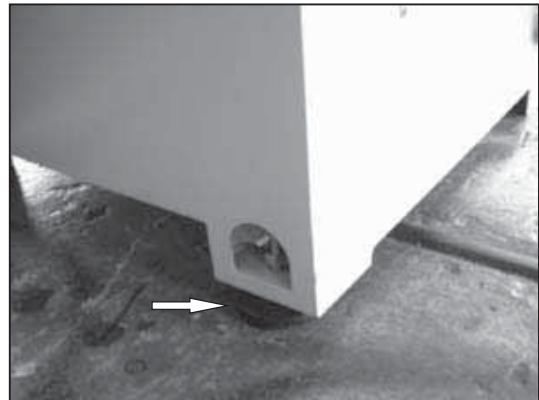

Fig.2

WARNING

- Before the machine is put on the floor, please first install level adjusting bases (as shown in Fig. 2 arrow marked) and adjust the level of the machine's working table to secure the sliding table's smooth movement and the machine's balanced running.
- Fig. 2 as marked is the machine after adjustment should be fixed to the floor.

2-2 SLIDING TABLE UNIT

ASSEMBLE

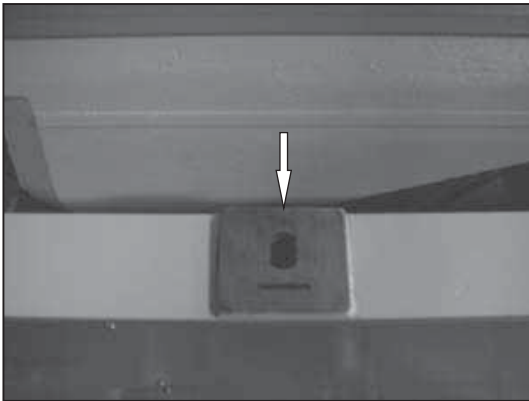

Clean the contact surface of the machine and the sliding table (Total 3 contact surfaces).

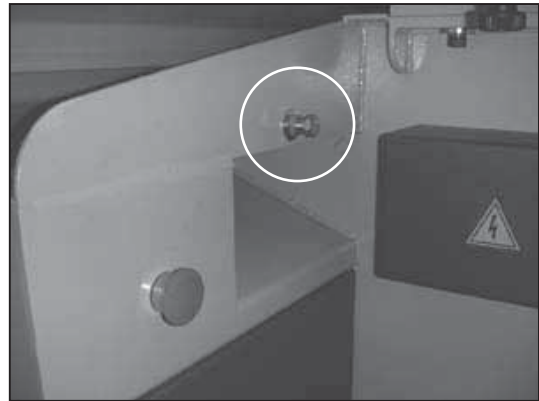

Put the sliding table on the contact surface and tightly against the adjusting screw.

Note : Ask persons to move the sliding table onto the machine to prevent hitting from influencing level during transportation. As per different size, the required manpower is 4-6 persons.

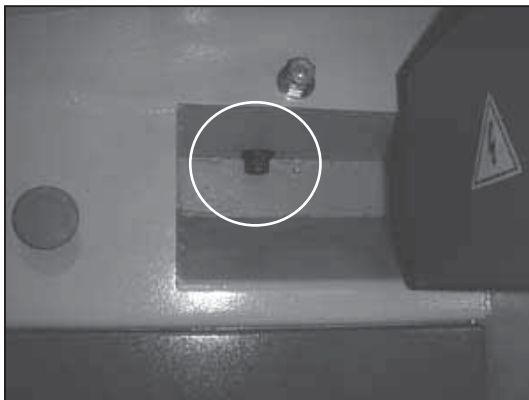

Tighten the fixing screw of the machine and the sliding table.

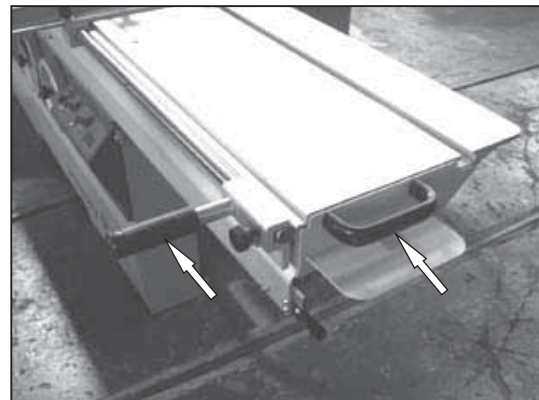

Put the handle and the sliding table handle onto the sliding table.

Note : After assembly of the sliding table is completed, the parallelism of the sliding table and the saw blade must be first adjusted.

ADJUST

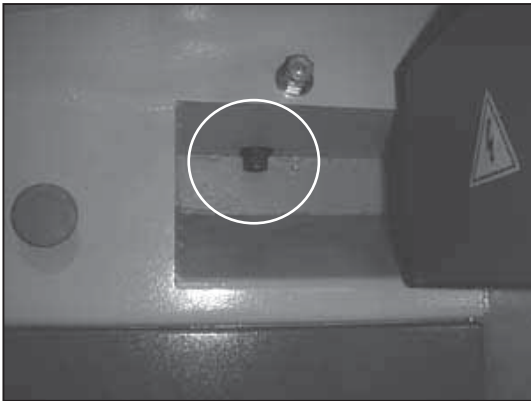

Loosen 3 fixing screws.

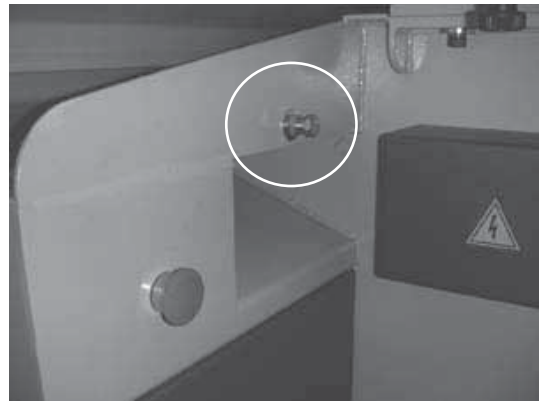

Adjust the adjusting screws at two sides of the machine to make the sliding table parallel to the saw blade and keep the gap as shown in the left drawing with the working table. After assembling, tighten the fixing screws.

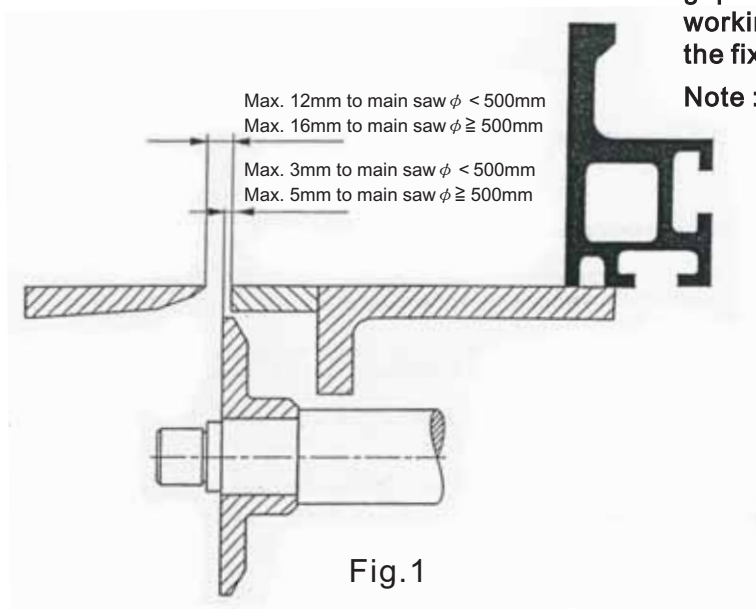

Note : The sliding table must 0.3mm higher than the working table (The height has been set before delivery, so don't freely adjust the height of the sliding table or the working table).

How to Use the Sliding Table Lock

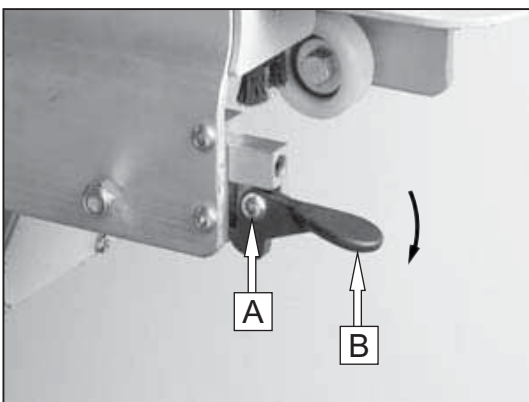

- Due to limitation of packing, Part A & B in the left drawing are put in the tool box before delivery.
- After the sliding table is installed at the back of the machine, please first install Part A & B at the position of the end of the sliding table in the left drawing.
- The safety lock can fasten the sliding table in the middle and the end.

Note : Before the sliding table is moved, make sure the safety lock is unlocked. Part Bin the left drawing is locked. By pressing down Part B, it can be unlocked.

2-3 CROSSCUT TABLE UNIT

ASSEMBLE

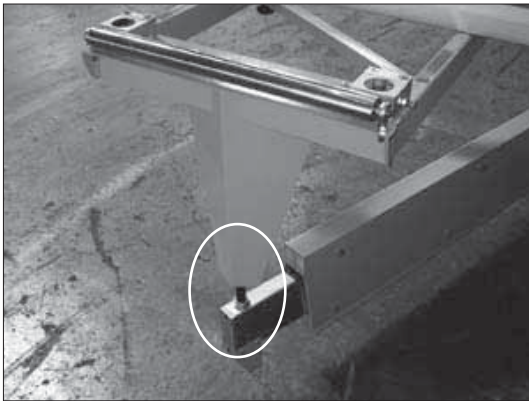

Put one end of the crosscut table into the projected round rod of the expansion pipe (apply the lubricating oil to the balls to prevent friction from noises).

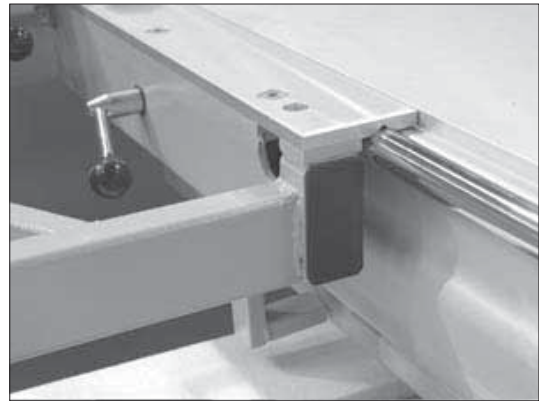

Put the other end on the round rod of the sliding table and put the locking bar under the round rod of the sliding table.

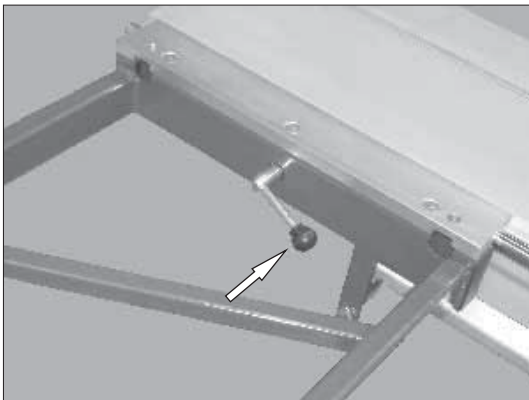

Tighten the handle to fasten the crosscut table.

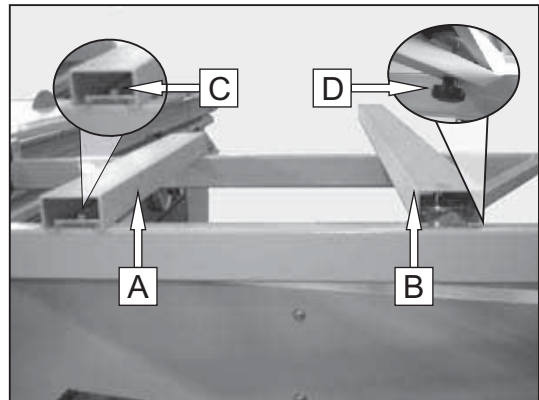

Put two C-shaped aluminum pipes into the crosscut table.

A aluminum pipe is the fixing aluminum pipe (Use the open wrench to tighten C for fixing).

B aluminum pipe is the moving aluminum pipe (Use hand to tighten D for fixing. Loosen D to make B aluminum pipe be movable).

ADJUST

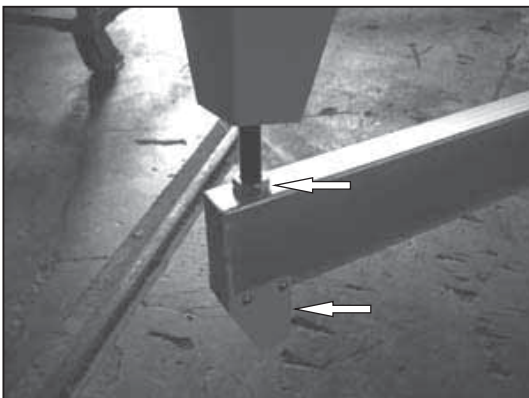

If the crosscut table isn't parallel to the working table, adjust the nut of the crosscut table and the expansion pipe and also adjust the nut in the cover plate. (See the left drawing.)

2-4 CUOSSCUT FENCE UNIT

ASSEMBLE

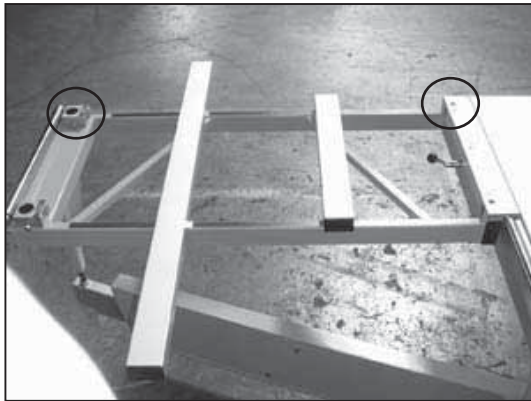

Put the crosscut fence into the positioning point of the crosscut table.

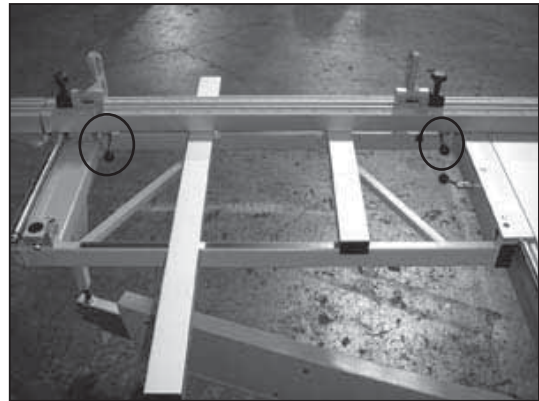

Press down the handle to fix the crosscut fence.

Note : If the crosscut fence is moved, please first adjust the perpendicularity of fence and saw blade before use.

ADJUST

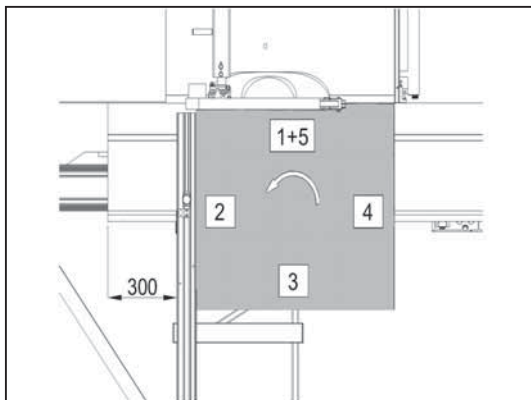

Fig.1

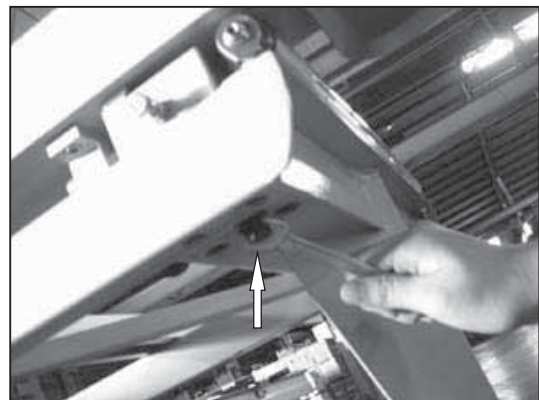

Fig.2

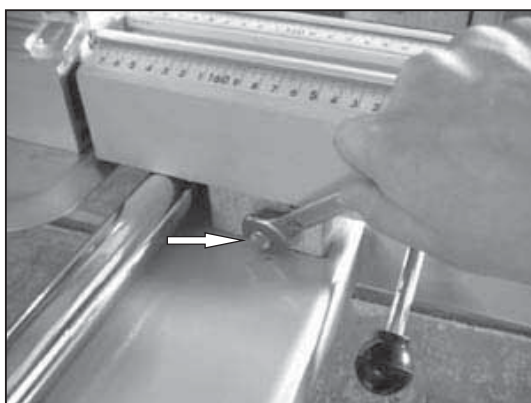

Fig.3

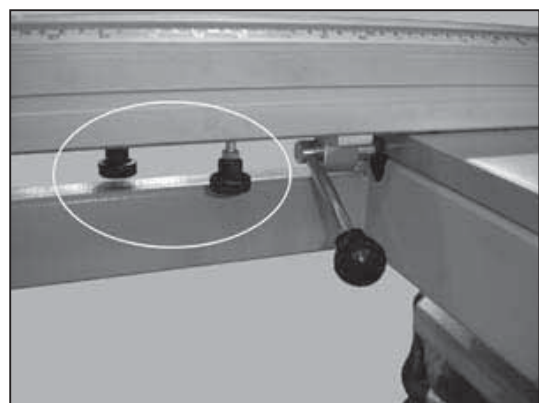

Fig.4

Adjusting Way :

1. Please keep 300mm distance between the fence and the sliding table. While cutting, please use saw in dia. 350mm/3.2t/100T, at 5000 r.p.m speed and wood board in 1000x1000x19 or (6/8") for trial cut.
2. Sequentially cutting NO.1~5 as Fig.1.
3. Measure the diagonal's error of the wood board to proceed adjustment Fig.2 parts, lock the nut Fig.3 after adjustment.
4. The two knobs in the Fig.4 is to fasten the scale on the crosscut fence.

2-5 RIP FENCE UNIT

ASSEMBLE

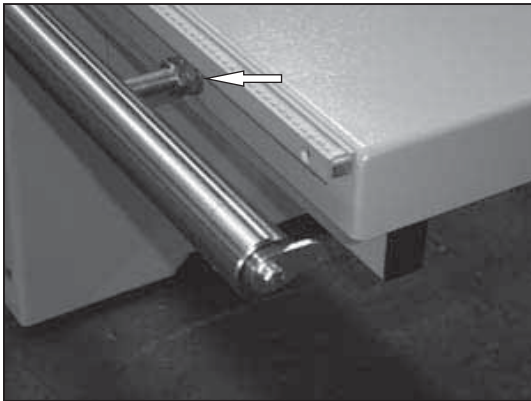

Lock the screw on the round rod into the right side of the working table, put into the rip fence base, adjust three nuts on the round rod to make rip fence parallel to the saw blade.

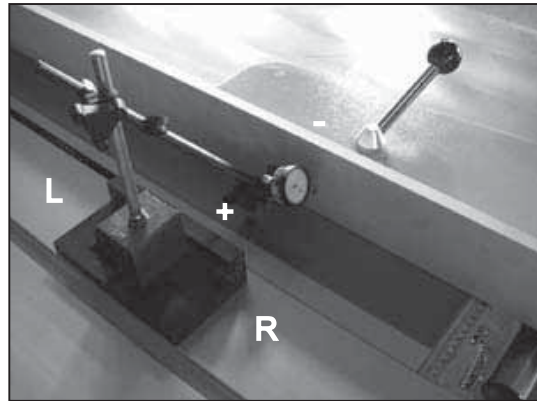

Use the gage to measure the parallelism of the rip fence and the main saw blade. Measuring way : The rip fence is fixed and the sliding table is pushed to the left. Measured tolerance is 0~0.1mm from the left to the right as the direction shown in the above drawing. (parallelism of the sliding table and the main saw blade must be first adjusted within tolerance.)



Adjust the eccentric wheel of the front end of the fence base to make the fence base parallel to the working table.



Adjust two eccentric wheels at the side of the fence base to make the aluminum fence parallel to the working table.

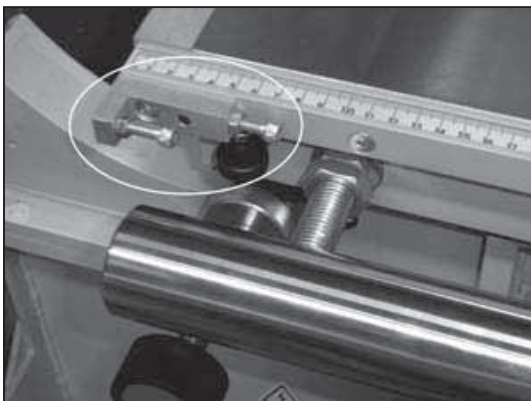

- Tighten the rip scale, adjust the limit screw on the stop block. The safe gap between the fence and the saw blade is suggested at 0.5mm.
- The screw at the left side of above drawing is the limit for cutting 90 degree.
- The screw at the right side of above drawing is the limit for cutting angle.

ADJUST

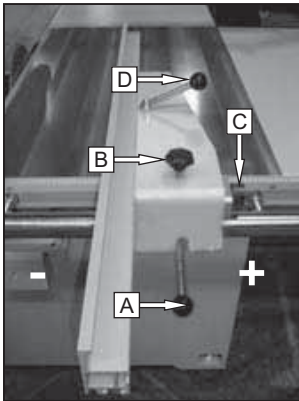

After the rip fence is moved, if the moving size and the target size have slight difference, the following is the operating way of the micro-knob :

1. Pull the handle (Part A) upwards, move the rip fence to near the target size.
2. Loosen the knob (Part B).
3. Turn the micro-knob (Part C) to the target size. To fasten rip fence, do above steps in reverse order. Clockwise turn micro-knob : - direction movement Anti-clockwise turn micro-knob : + direction movement. To change the aluminum fence, loosen the handle (Part D).

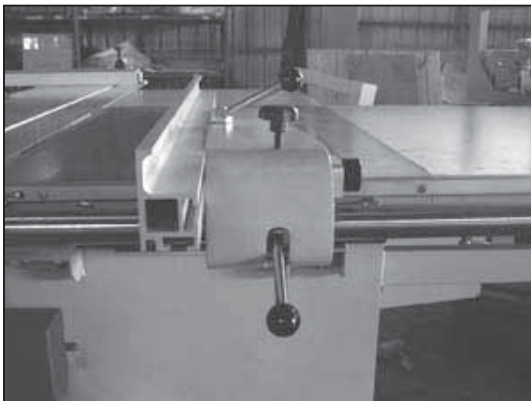

Above drawing is the position of aluminum fence at 90 degree cutting.



Above drawing is the position of aluminum fence at cutting angle.

2-6 EXTENSION TABLE

ASSEMBLE MAIN TABLE EXTENSION

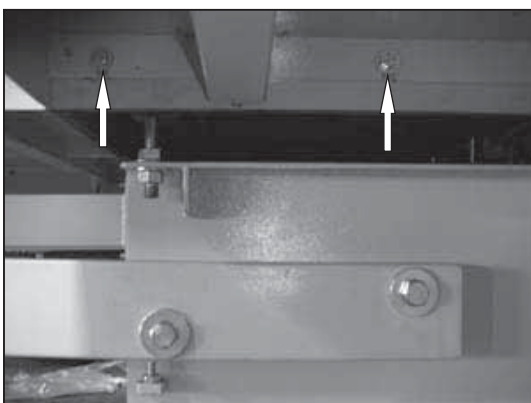

Loosen about 3~5mm of 3 metal sheet fixing screws at the left side of the machine, put extension metal sheet on the fixing screws and slightly tighten the screws.

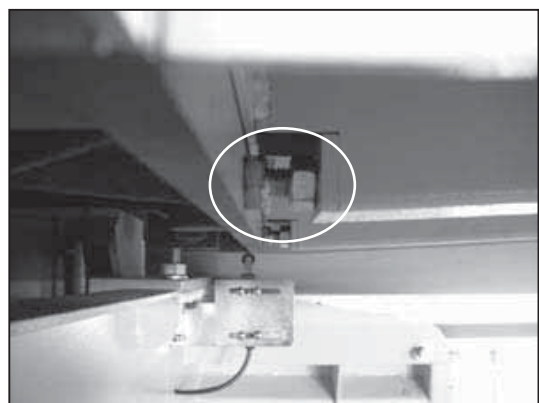

Adjust 2 adjusting bolts of the extension metal sheet to make the metal sheet and the main working table become a plane.

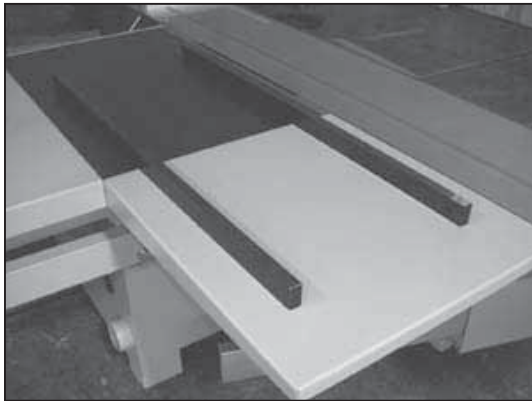

Measure if the main table extension and the main table become a plane.

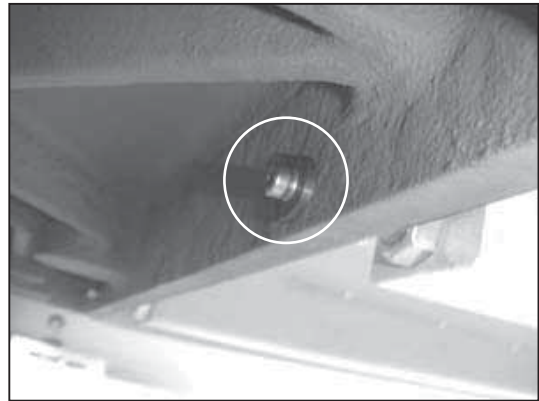

Adjust and fasten 2 adjusting bolts and 3 metal sheet fixing screws.

ASSEMBLE WIDTH EXTENSION TABLE

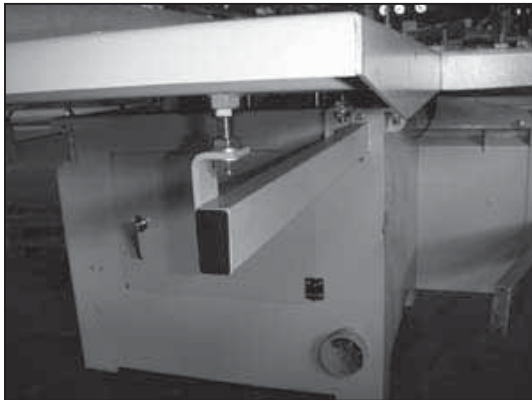

Lock the support into the back of the machine.

Note : The opening of the support must be outwards as shown in above drawing.

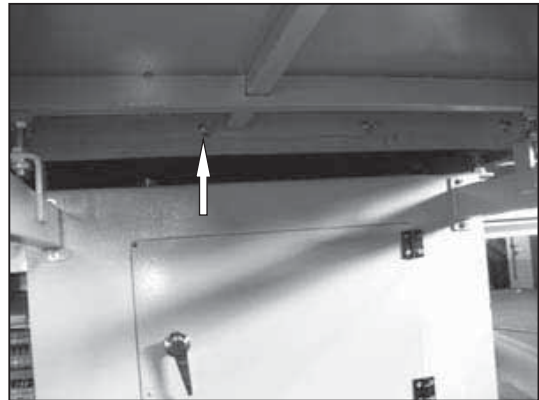

Loosen 3~5mm of 4 metal sheet fixing screws at the left side of the machine, put width extension table on the fixing screws, slightly tighten the screws.

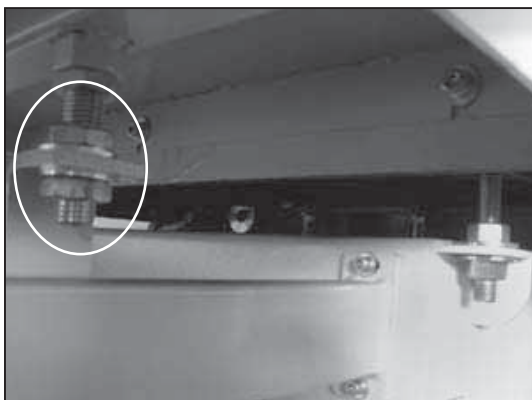

Put the adjusting bolt on the metal sheet onto the support and adjust the nut to make width extension table and main table become a plane.

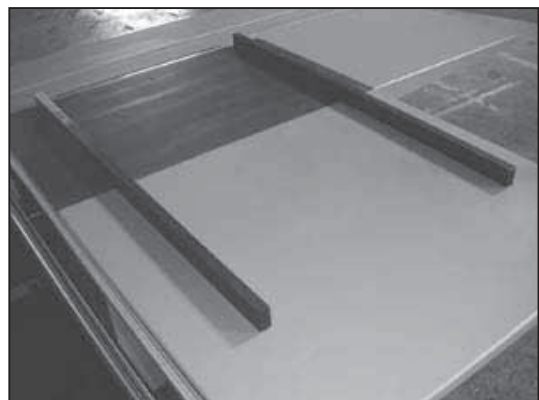

Measure if the width extension table and the main table become a plane.

2-7 DUST GUARD UNIT

SIMPLE TYPE SAW GUARD

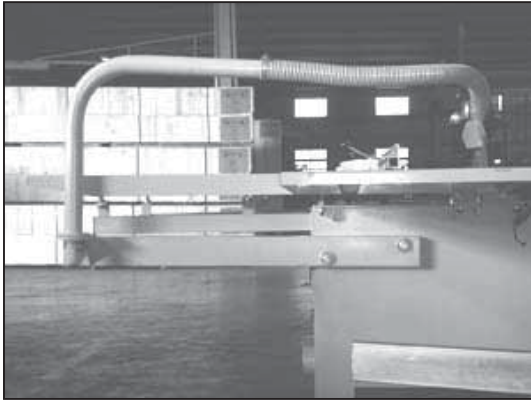

Install the dust collection fixing rack and the dust collection pipe onto the left side of the machine as shown in above drawing.

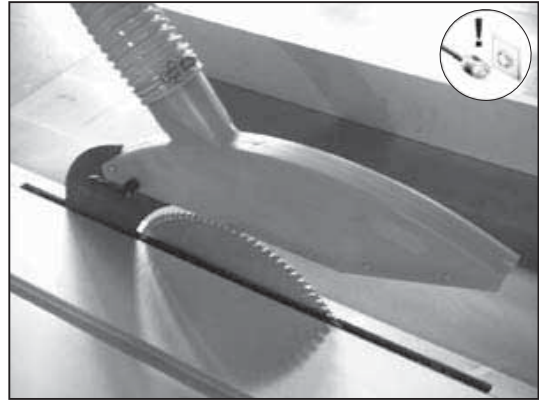

Install the dust collecting hood on the ribbing knife, connect dust collection hose, use clamp to fix the hose as shown in above drawing.

Diameter of dust collection hose is ϕ 60mm.



Put the dust collection hose into the dust collection hole under the fixing rack.

Diameter of the fixing rack's hose is ϕ 60mm.

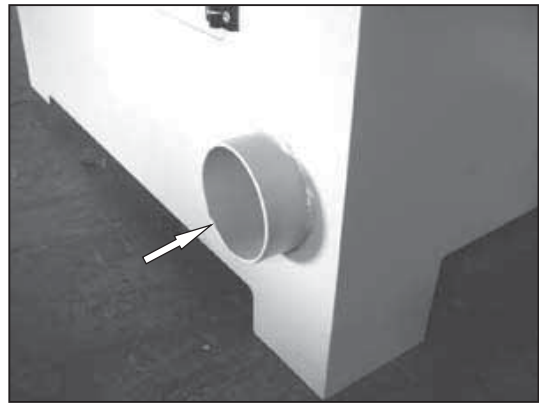

Put the dust collection hose into the dust collection hole at the back of the machine.

Diameter of hose at the back of machine is 4".

WARNING

Before the machine is used to cut workpiece, Please make sure the dust collector work normally.

Note : The required air speed at the end of flexible tube is 30~34m/sec. The required air volume of the machine is 1220~1390 m³/hr. (43,000~49,000 cuft/hr)

LUX SAW GUARD

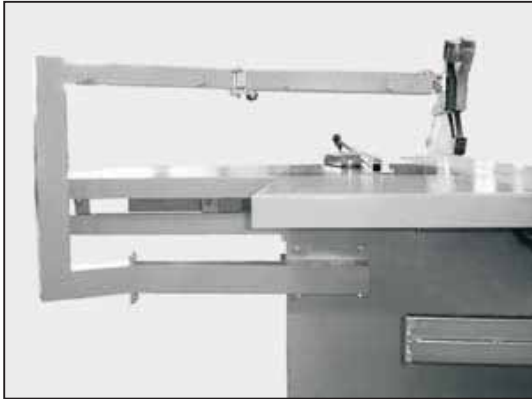

Install the dust collection fixing rack onto the left side of the machine as shown in above drawing.

⚠ WARNING

Before you install the safety guard, please lower the saw under the table.

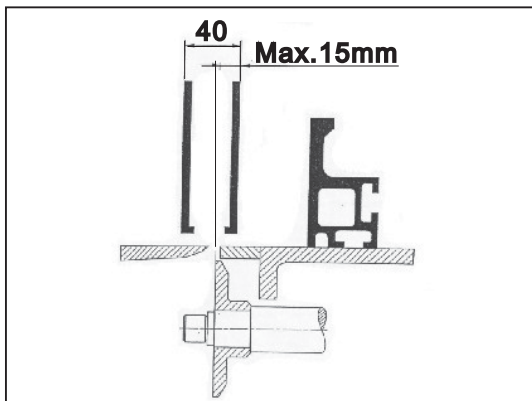

Please keep safe distance between the safety guard and the saw as shown in above drawing.

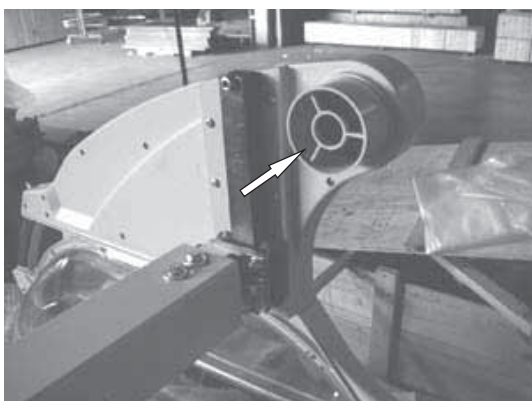

Put the dust collection hose into the dust collection hole at the back of the guard.
Diameter of hose at the back of machine is 3".

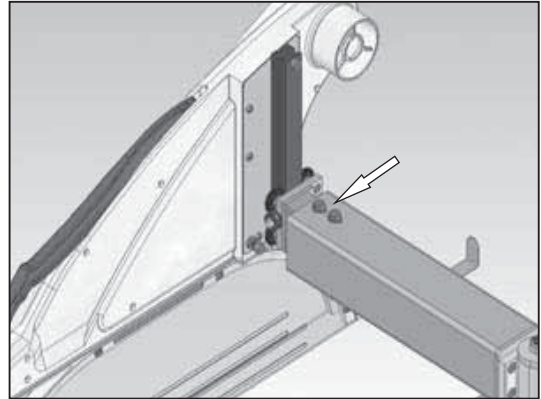

Adjust the guard parallel with the saw and tighten the screw as shown in above drawing.

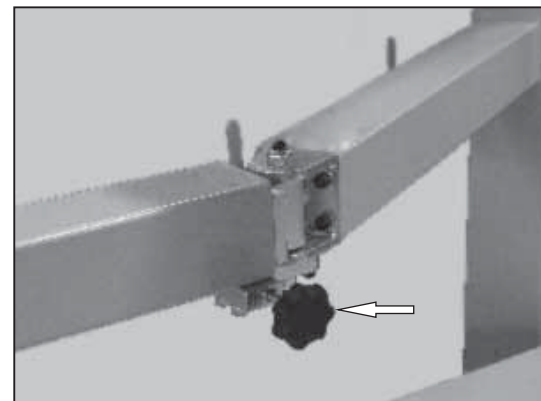

Tighten the knob to fix the guard. Loosen the knob, the guard can be moved as shown in above drawing.

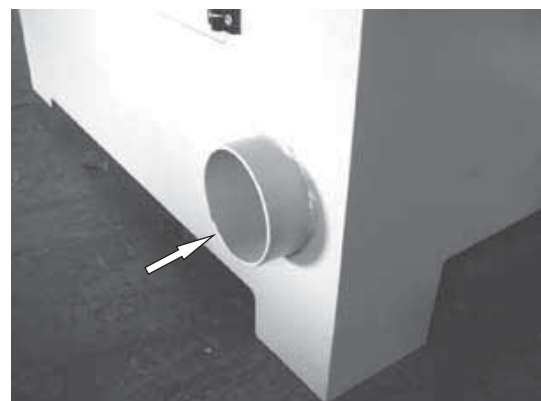

Put the dust collection hose into the dust collection hole at the back of the machine.
Diameter of hose at the back of machine is 4".

⚠ WARNING

Before the machine is used to cut workpiece, Please make sure the dust collector work normally.

Note : The required air speed at the end of flexible tube is 30~34m/sec. The required air volume of the machine is 1220~1390 m³/hr. (43,000~49,000 cuft/hr)

PUSHING STICK INSTALLING

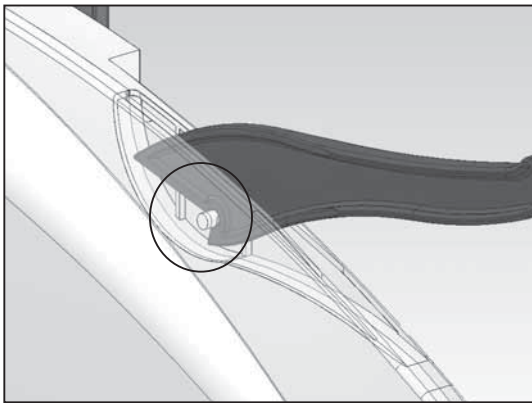

Install the pushing stick on the holder by degree 45.

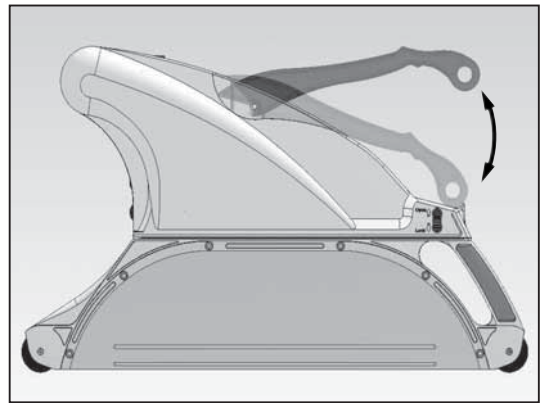

Lightly put down the pushing stick, then the pushing stick can be fixed.

ADJUST SAFETY GUARD

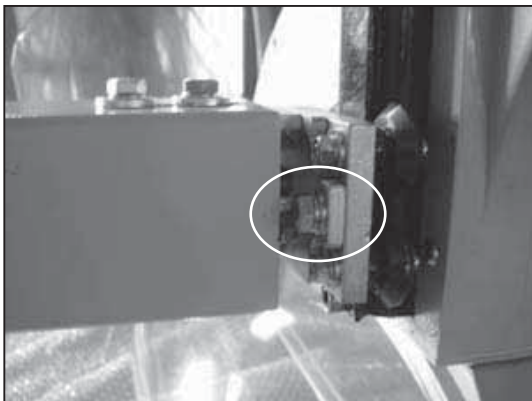

- Use hand to slightly move the saw guard up or down.
- The screw shown in left drawing is to adjust the tightness/looseness of up / down movement of the saw guard.
- The safety guard can be moved up to any place but must be firmly tightened at that place to avoid it moving down. After it's used for a long time, the part will be worn. So, please adjust its tightness again.

CHANGE SAFETY GUARD

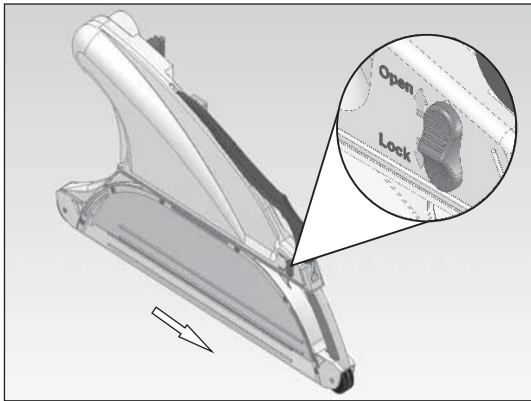

Push up the lock button on the saw guard loosen the saw blade shield to outward can be replacement.

WARNING

- In order to prevent the saw blade touch the saw shield during the replacement, kindly downward the saw blade to the bottom and move the saw guard unit to the upward.

- While cutting workpiece :

- At 90° cutting, 90° special safety guard must be used as Fig. 1.

- At angular cutting, special angular safety guard must be used as Fig. 2.

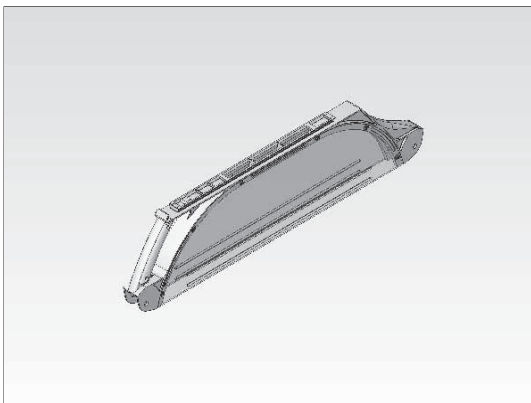

Fig.1

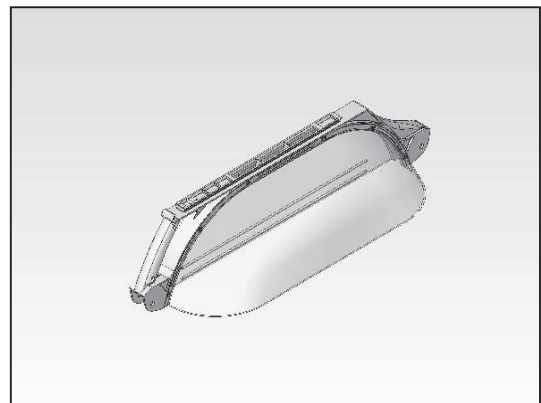
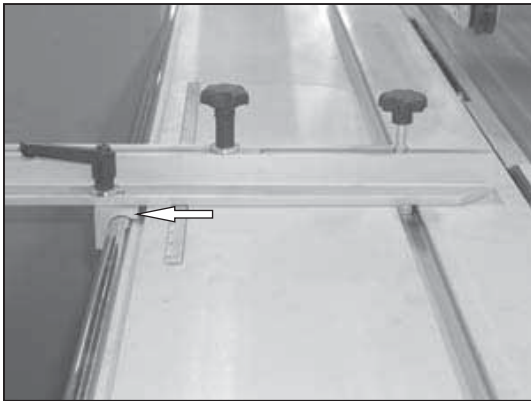

Fig.2

2-8 MITER FENCE UNIT

ASSEMBLE



Put the slide block on the bevel cutting fence into the round rod of the sliding table.

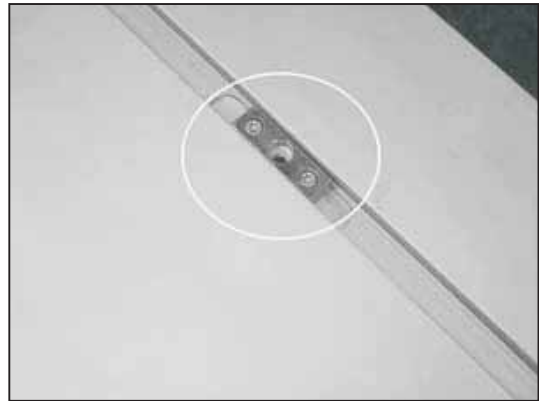

Lock the fixing block on the sliding table.

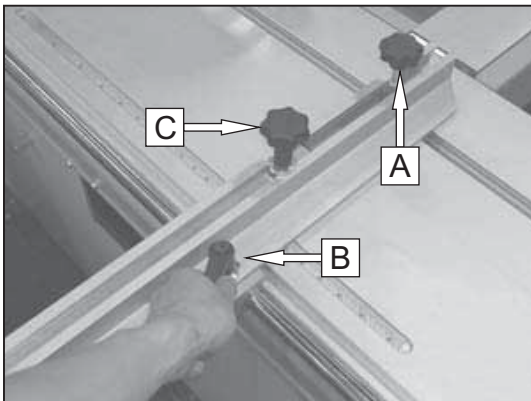

- Tighten knob A to fasten the center point of bevel cutting fence.
- Tighten handle B to fasten the bevel cutting fence. Loosen it to make the bevel cutting fence become an arc movement.
- Loosen knob C and push outwards to extend the bevel cutting fence.

2-9 RIVING KNIFE UNIT

ADJUST

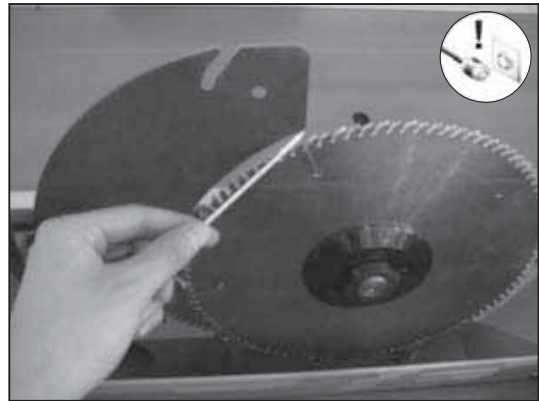
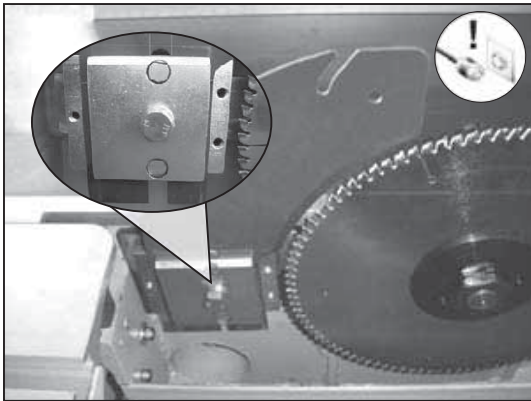

- Loosen the fixing screw on the riving knife base.
- Adjust the 3 adjusting screws at the two sides of the fixing screws as the projected place shown in the above drawing.

Note : Before adjusting the riving knife, please first open the saw blade guard. Please refer to 2-10 for detailed operation.

Measure the relative size of the riving knife and saw blade.

⚠ WARNING

After adjustment of the riving knife is completed, please make sure to tighten the fixing screw on the riving knife base.

RELATIVE SIZE OF THE RIVING KNIFE AND MAIN SAW BLADE

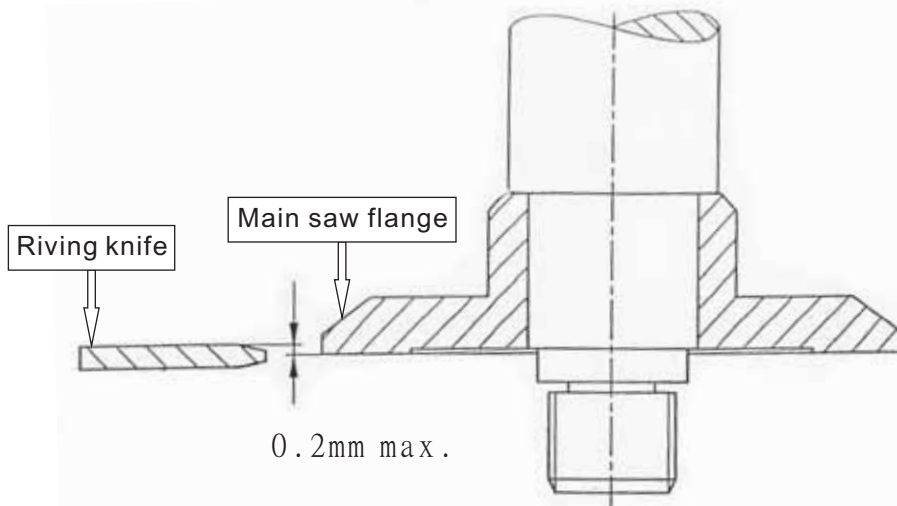
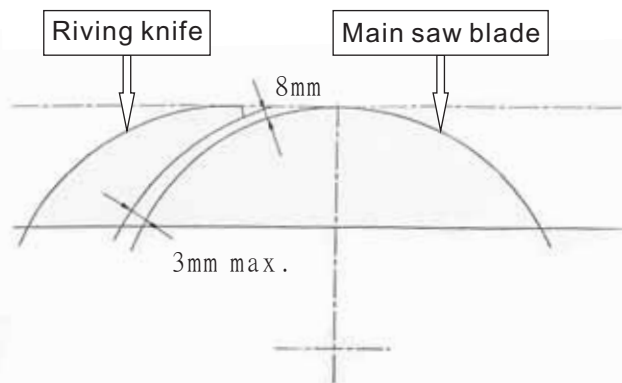
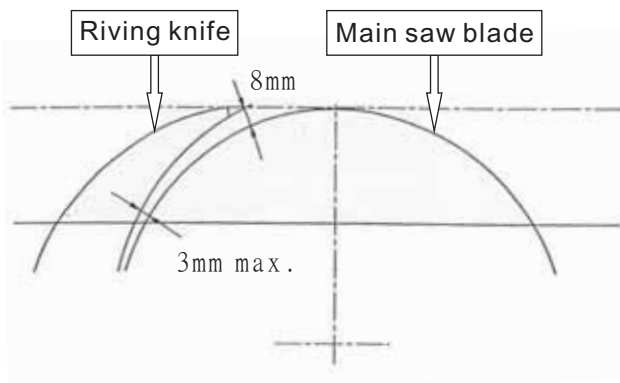

2-10 MAIN SAW UNIT

CHANGE MAIN SAW BLADE

⚠ DANGER

- Before changing saw blade, please confirm if power is closed.
- At changing saw blade, please put on the protective film to avoid any damage during changing.

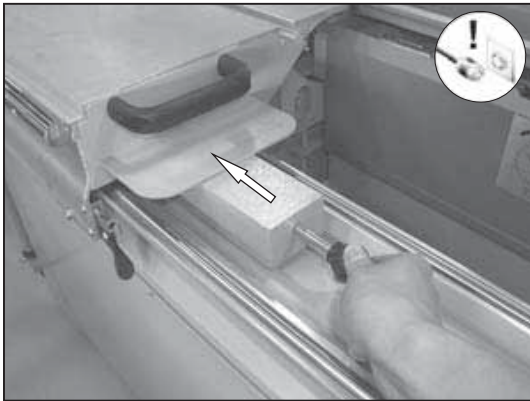

Push the sliding table towards the bottom. When the pusher rod is seen, push the ball on the pusher rod inwards to push the sliding table to the bottom.

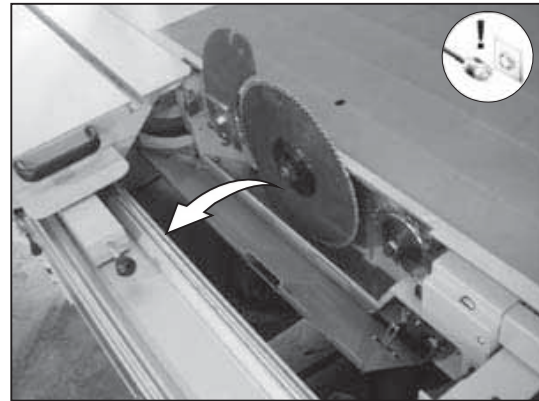

Open the saw blade guard.



Raise the main saw blade to the highest position. Turn the saw blade until the fixing pin is inserted into the spindle fixing hole.

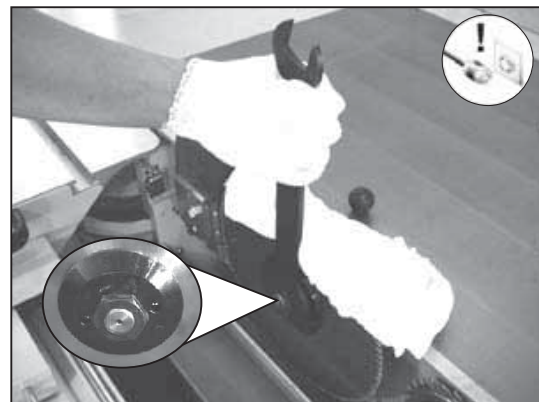

Use wrench to clockwise loosen the nut, clean the flange and new saw blade and then install them back to the spindle.

⚠ DANGER

The flange fixing nut of main saw blade must be tightened by torque 300kg/cm.

CHANGE SPINDLE'S ROTATING SPEED

DANGER

Change spindle's rotating speed, please confirm if power is closed.



Turn the saw blade's lifting hand wheel to lower main saw blade to the bottom.

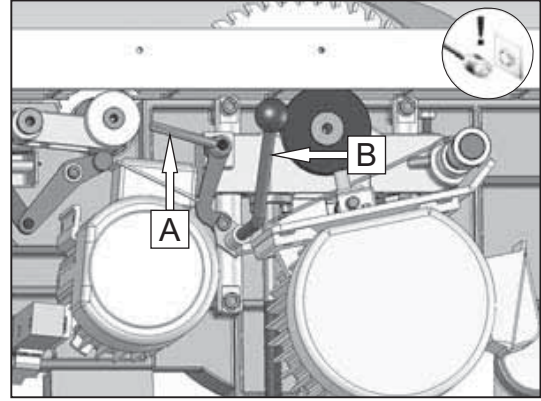

Open the service door at the back of the machine, loosen the adjust handle (Part A), press down the handle (Part B) to raise the motor.

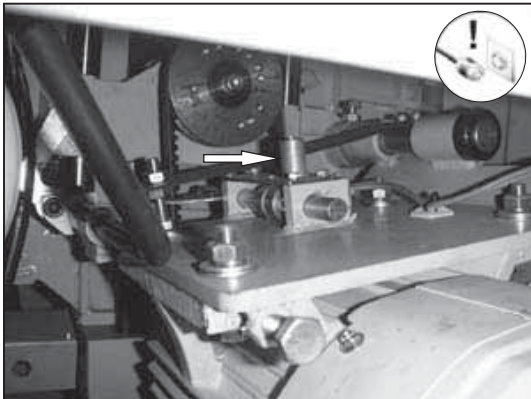

Pull the rotating speed knob upwards as shown in above drawing. Change the rotating speed knob and belt as per the motor's rotating speed list. After that, push the handle upwards to make belt produce tension. Tighten adjust handle. The change of rotating speed is completed.

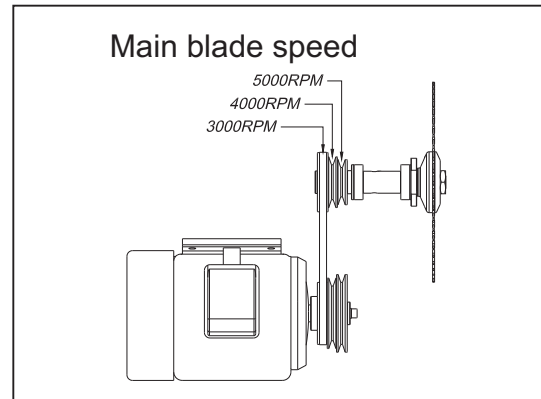

Above drawing is motor's rotating speed list. Speed in order of main blade to motor is 5000rpm、4000rpm、3000rpm.

ADJUSTMENT FOR MAIN SAW HEIGHT AND TILTING.

Hand wheel operation

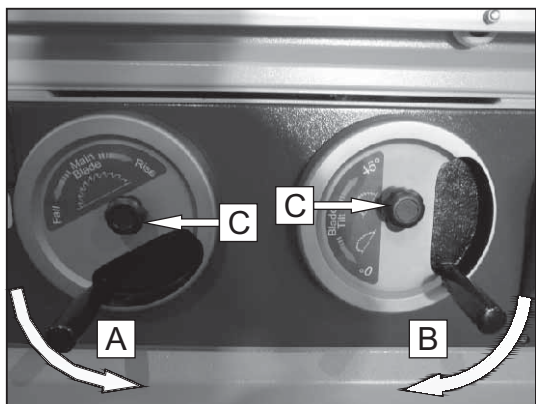

- A. Hand wheel for main saw blade height adjustment. (As displaying in the diagram, the arrow direction is downward, on the contrary, upward.)
- B. Hand wheel for main saw blade tilting adjustment. (As displaying in the diagram, the arrow direction is tilting angle increasing, on the contrary, tilting angle decreasing.)
- C. After adjusting the hand wheel, please lock up the knob as the C part in the diagram for fixing the hand wheel.

Mechanical display

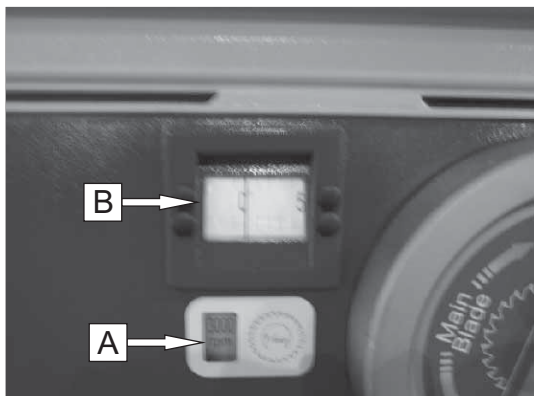

- A : Speed display for main shaft.
- B : Tilting angle display for main saw blade.

Digital display

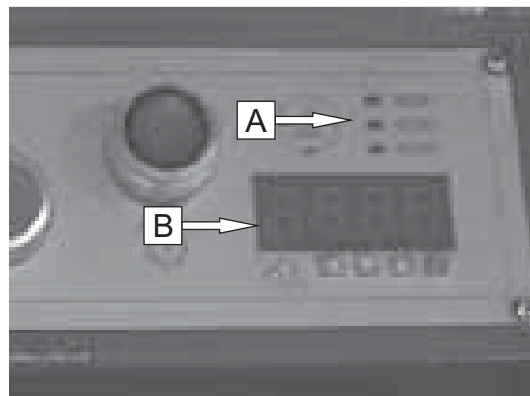

- A : Speed display for main shaft.
- B : Tilting angle display for main saw blade.

Adjustment for tilting angle display:

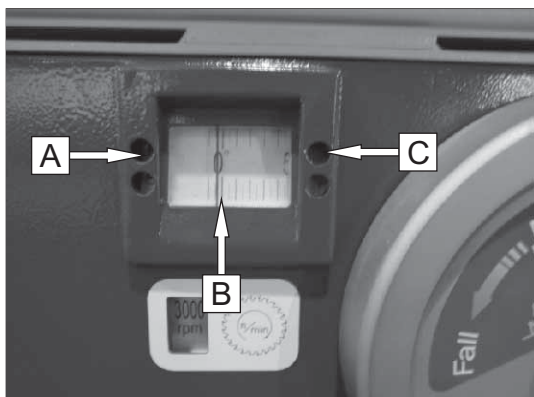

- #### Mechanical display
1. First, take off the black little circle cover. (as in diagram A)
 2. Turn the indicator to 0° with hand wheel, then loose these two screws at A position in diagram.
 3. Turn the indicator to 45°, then loose these two screws at C position in diagram.
 4. Lock up all the screws after adjustment.

Please refer to chapter 3-3 for digital display adjustment.

2-11 SCORING SAW UNIT

OPERATE

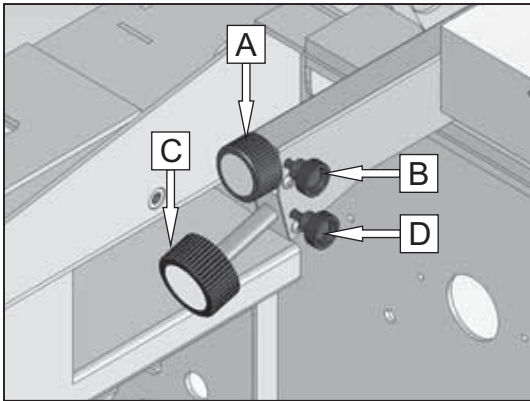

A : Forward/backward adjusting knob.

B : Forward/backward fixing knob.

C : Lifting displacement knob.

D : Lifting fixing knob.

CHANGE

⚠ DANGER

- Before changing the saw, please make sure if the power is closed to void danger.
- Before changing the saw, please install the protective film to protect the saw and avoid danger while change.

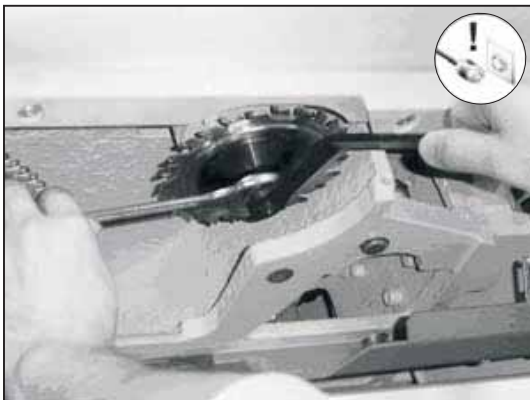

Push the sliding table to the bottom, open the saw blade guard (refer to 2-8 for detailed operation), use the handle to remove the flange fixing nut, clean the flange and new saw blade and then install them back to the scoring saw's arbor.

⚠ DANGER

The flange fixing nut of the scoring saw must be tightened by torque 250kg/cm.

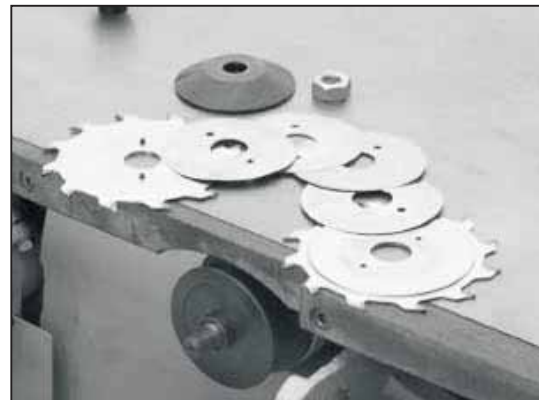

- The cushion in above drawing is used to adjust the cutting width of the scoring saw being bigger than the cutting width of the main saw blade to make the cutting workpiece look nicer.
- Thickness of the attached scoring saw is 2.8mm but it can be adjusted to 4.3mm.
- Cushion's size & quantity :
 - 0.1mm → 1pcs.
 - 0.2mm → 1pcs.
 - 0.3mm → 4pcs.

3-1 POWER CONNECTION

⚠ DANGER

- Power connection must be done by the qualified electronic engineer.
- The machine must have an earth wire to prevent electric leakage from happening electric shock and even death.

Connect the wiring step :

1. Make sure the voltage of the machine conforms to your company's power.
2. Use the specific tool to open the power controlling box to connect power.
3. Connect three power wires to terminal L1(R), L2(S), L3(T) as shown in the Fig.1 and Fig.3. Connect the earth wire (green-yellow) to PE terminal.
4. Start motor to check if the rotating direction of the main saw blade and the scoring saw is the same direction as indicated in chapter 1-4.
5. If the saw blade rotates in reverse direction, please stop rotating and shut power off, exchange terminal L1 position for L2 position and check again.

POWER DISTRIBUTION UNIT



Fig.1

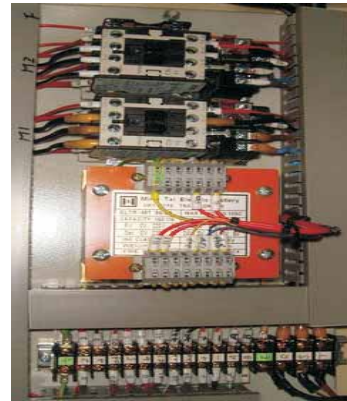

Fig.2

POWER DISTRIBUTION UNIT 【CE TYPE】



Fig.3

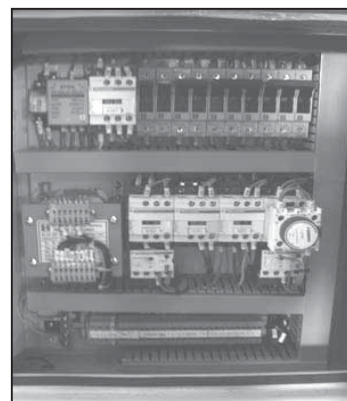

Fig.4

OPEN POWER CONTROLLING BOX



Use the specific tools enclosed in the tooling box.

⚠ DANGER

Please make sure the power is turned off before opening the electric cabinet door.

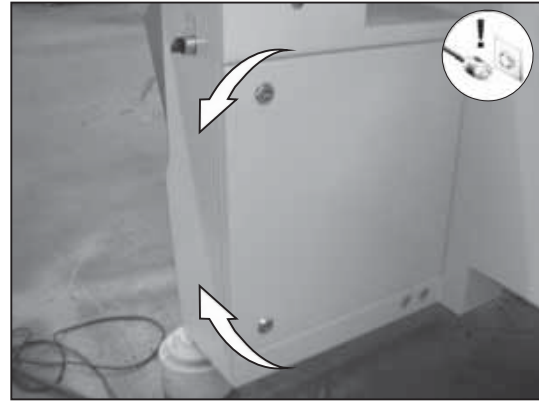

According to the Fig marked direction can be open the electric cabinet door.

Notes for wiring :

1. Power input : AC5V and AC12V / 50~60HZ.
2. Signal input : Standard proximity sensor or encoder A, B phase signal (DC12V)
3. Unit of measurement : Degrees.
4. Don't connect the shielded cable of the induction unit to circuit 0volt or GND.
5. Sensor shielded cable please direct connection to the controller.
6. For reducing controller interference. Please separate signal wire and power wire.
7. The programmable controller is intended of use in Zone B typical industrial environment.

⚠ DANGER

- The fuse in above NO.6 can't exceed over 3A. Please choose proper fuse by yourself.
- Electrical technician and operator must obey above-mentioned items. If they are freely changed and hence causing controller burnt out or abnormally mechanical damage, the consequence will be borne by yourselves.

3-2 OPERATION OF CONTROL PANEL

EXPLANATION OF MAIN KEYS

Digital display

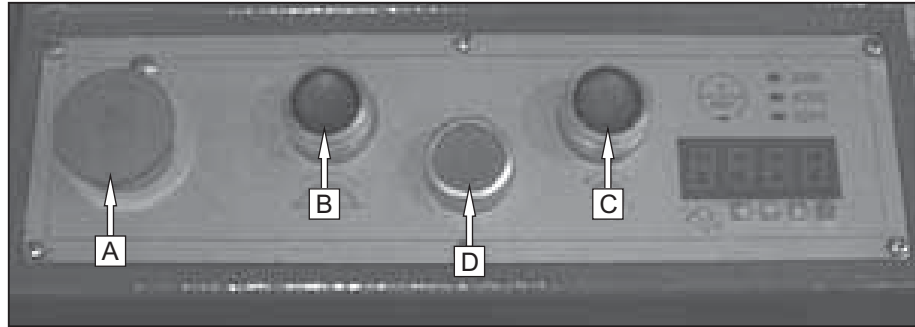

Mechanical display

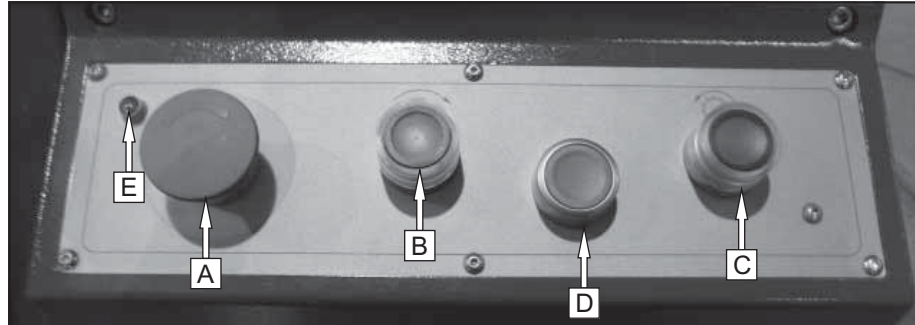

- A. Emergency stop button----- Urgently shut down the machine's power.
- B. Main saw start button----- Start main saw.
- C. Scoring saw start button----- Start scoring saw.
- D. Saw blade stop button----- Stop the main saw and scoring saw.
- E. Power light----- Power light.

EXPLANATION OF ANGLE MACHINE'S KEYS

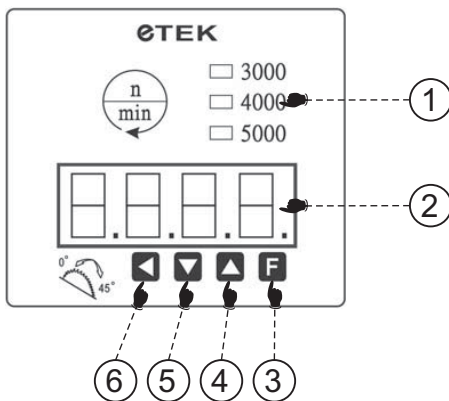

Functions :

1. R.P.M display 3000、 4000、 5000.
2. 4 Digits display, one decimal point.
3. Set button.
4. Set button.
6. Set button.

Notes for angle screen :

- The angle screen of the machine adopts micro-computer single chip controller, so it's stable and safe under long-term use. Please refer to chapter 3-3 for detailed operation.
- When power is closed, the angle screen doesn't have any display. After power is started, the angle that the angle screen shows is the angle when power was closed last time. After power is closed, please don't adjust the angle and tighten the fixing knob on the hand wheel.
- If the angle is adjusted accidentally while power is closed, please first return angle to zero to avoid the cutting angle and the actual angle being not the same after power is started. Please refer to chapter 3-3 for operation of returning zero.

3-3 OPERATING INSTRUCTION FOR CORRECTING CURRENT DIMENSION

Current figure show on the display is 21.5

To correct in 35.1, the steps to operate are as the following diagrams demonstrated.

DIAGRAM 3:

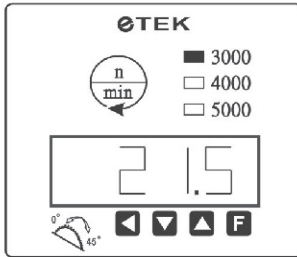

The display shows 21.5

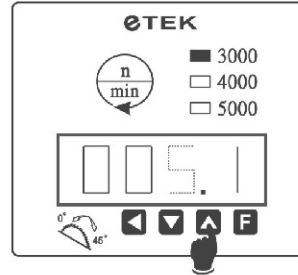

Step 4:
Press button once and press button 5 times. The display shows 005.1 and 3th digital (5) flash.

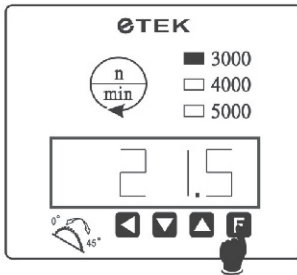

Step 1:
Press button 5 seconds, unrelease button.

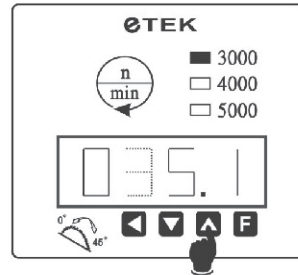

Step 5:
Press button once and press button 3 times. The display shows 035.1 and 2th digital (3) flash.

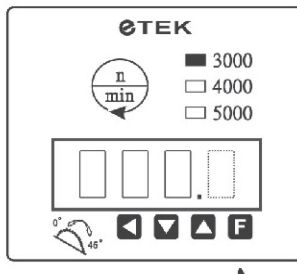

Step 2:
Release button the display shows 000.0 and 4th digital flash.

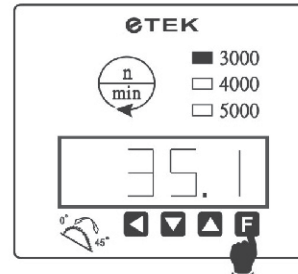

Step 6:
Press button 5 seconds the display shows 35.1, and stop to flash.

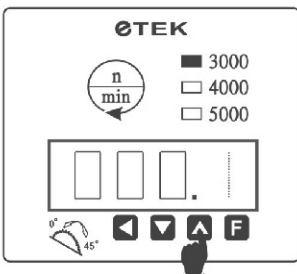

Step 3:
Press button once the display shows 000.1 and 4th is flash.

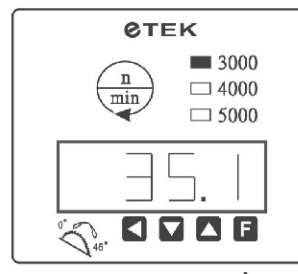

Step 7:
Correcting completed.

3-4 DESCRIPTION OF PARAMETER SETTING

Current parameter is 3000

To correct in 4255, the steps to operate are as following diagrams demonstrated.



1. The operators have to pay their attention not to make any change. Otherwise, the controller is possible to be unusual and damaged the machine, please caution.
2. Unless by authorized technicians, do not make any alteration or modification in operating the machinery, so as to avoid machinery operation in incorrect dimensions and to prevent any hazard.

DIAGRAM 4:

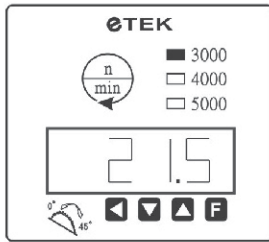

The display shows 21.5

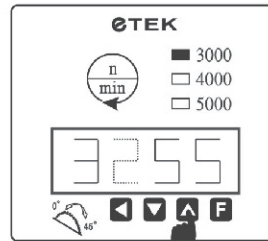

Step 5:
Press button once and press button 2 times. The display shows 3255 and 2th digital (2) flash.

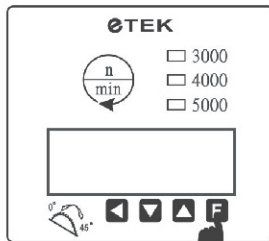

STEP 1:
Turn off the power. Press button (unrelease button) then turn on the power.

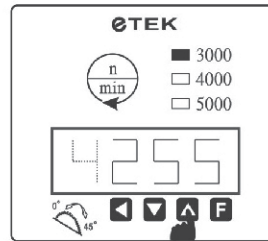

Step 6:
Press button once and press button once. The display shows 4255 and first digital flash.

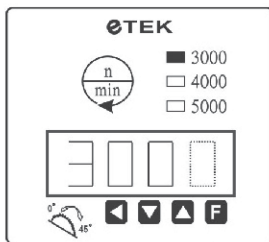

Step 2:
Release button the display shows 3000 and 4th digital is flashing.

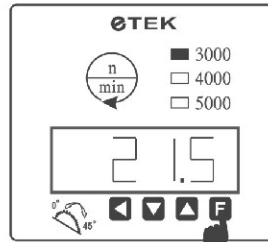

Step 7:
Press button 5 seconds the display shows 21.5, and stop to flash.

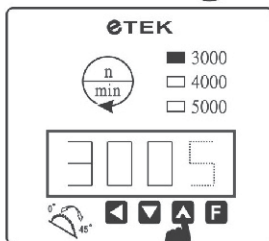

Step 3:
Press button five times the display shows 3005 and 4th digital is flashing.

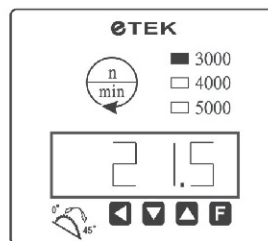

Step 8:
Setting completed.

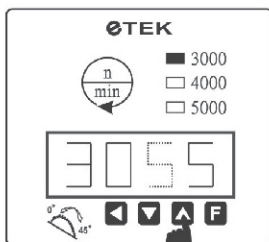

Step 4:
Press button once and press button 5 times. The display shows 3055 and 3th digital (5) flash.

4-1 MAINTENANCE OF THE SLIDING TABLE

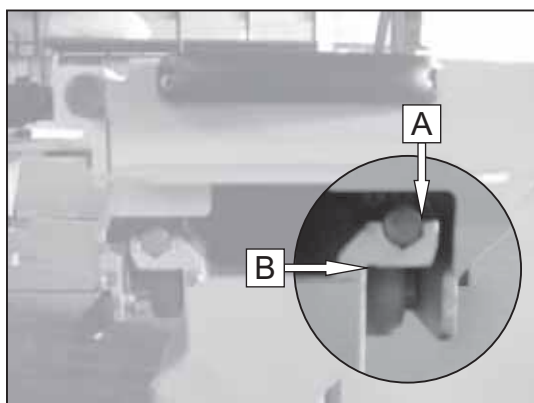

- Clean the contact surface (Surface A) of upper slide base and lower slide base.
- Clean the contact surface (Surface B) of lower slide base and the roller.
- Periodically clean above contact surfaces to keep long-term accuracy of machine.

4-2 MAINTENANCE OF ANGLE SLIDE RAIL

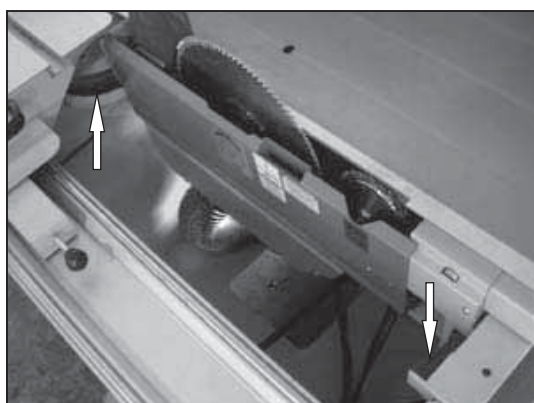

- Clean dust or wood chips on slide rail.
- After cleaning, apply the lubricating oil. Please refer to the following list to choose the lubricating oil.
- Periodically maintain above contact surfaces to keep long-term accuracy of machine.

ISO DIS-3498	LUBRICATING CYCLE	LUBRICATING WAY
XM2	6 months	Lubricate on the machine
BRAND		
MOBIL	ESSO	SHELL
MOBILUX 2	BEACON 2	ALVANIA R2

List 1

4-3 SAFETY CHECK 【CE】

WARNING

Do safety check at least twice every week to secure emergency switch's normal function.

CHECK OF EMERGENCY STOP SWITCH

Steps of check :

1. Connect to power, start the main saw blade and the scoring saw to make the machine run.
2. Push each emergency stop of machine and check if the saw blade and the scoring saw completely stop within 7 seconds.
3. When the emergency stop starts, operate the machine to see if it works.
Remarks : When the emergency stop starts, the machine doesn't have any action.
4. If the emergency stop is out of order, please immediately stop operation and respond to the supplier.

CHECK OF SAFETY CONNECTION SWITCH

Steps of check :

1. Connect to power, open safety door (i.e. saw blade's guard and service door at the back of the machine).
2. Operate the machine. At this time, the machine doesn't have any action.
3. Close the safety door and operate the machine again.
4. If machine works normally, that means the safety connection switch is normal.
5. If machine doesn't have any action when the safety door is closed, please stop operation immediately and respond to the supplier.

CHECK OF BRAKE

Steps of check :

1. While the saw blade and the scoring saw are running, push the saw stop switch or the emergency stop switch.
2. At this time, the saw blade and the scoring saw should completely stop within 7 seconds.
3. If the brake time exceeds 5 seconds, please immediately stop operating machine and respond to the supplier.

5.TROUBLE SHOOTING GUIDE ▶▶▶

TROUBLE	CHECK CAUSE	ACTION
1. LED no any display	1. Check if power AC 5V and AC 12V are normal.	Input correct voltage.
	2. If voltage is normal, that means controller is damaged.	Respond to supplier for repairing.
LED's shown 2. value isn't the actual value	1. Check if the shown size is correct.	Correct controller's size as per actual size. Please refer to chapter 3-3 for detailed correction.
	2. Check if parameter is correct.	Respond to supplier to get correct parameter. Please refer to chapter 3-4 for detailed parameter.
LED displays normally but LED 3. value does not react when angle moves.	1. Check if spindle connecting device between encoder and machine comes off or is damaged.	If the spindle connecting device is damaged, please change the encoder.
	2. Use voltmeter to measure if A,B phase have DC 12V and OV reaction.	If A,B phase don't have any reaction, please change encoder.

MACHINE BODY

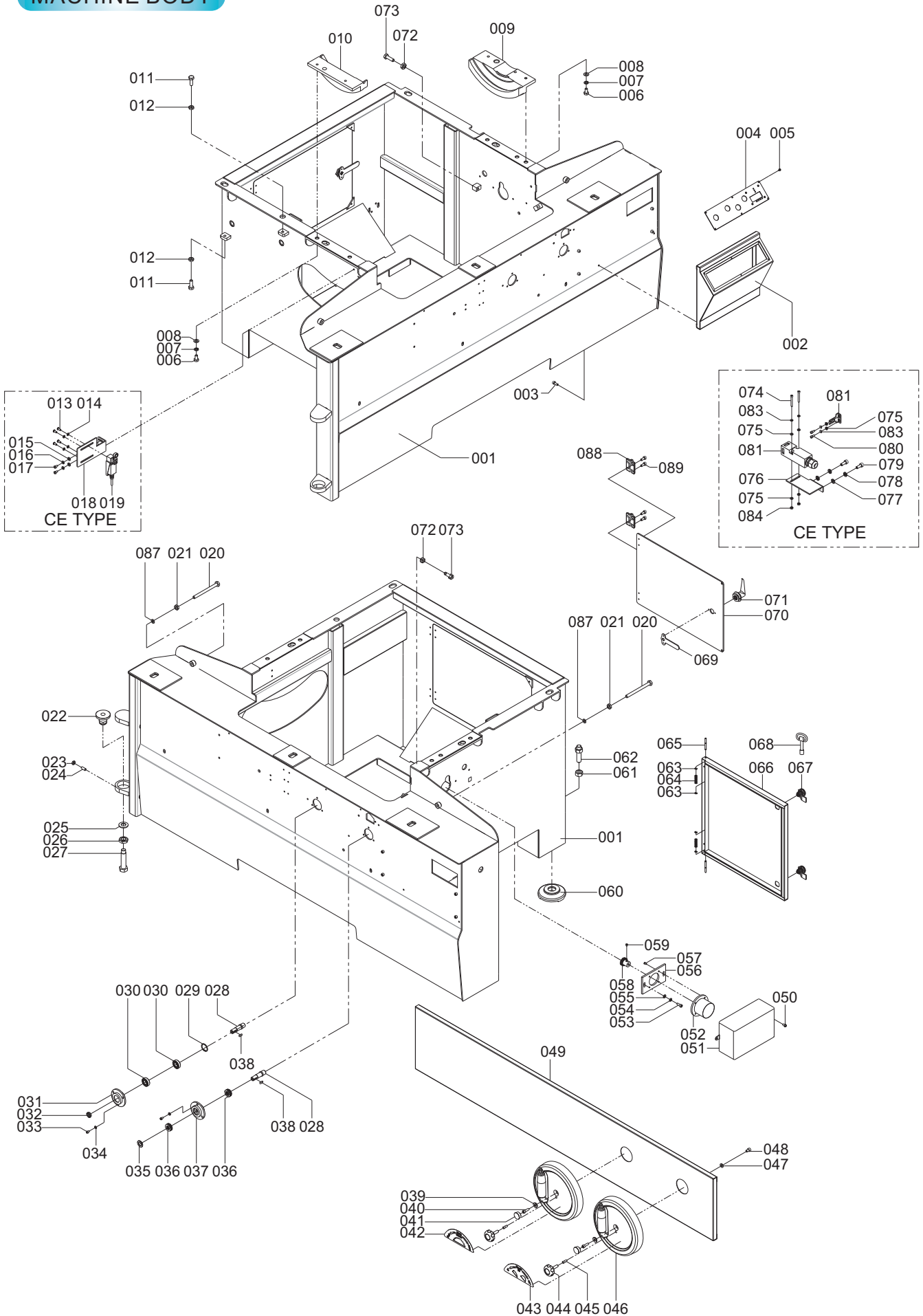

NO.	FIG. NO.	DESCRIPTION	NO.	FIG. NO.	DESCRIPTION
001	LST-A001	Body	045	NST-427-0-0	Stop Pillar
002	LST-A004	Electron Part Box	046	NST-403-1-0	Handle Wheel
003	401022053	Cap Screw M6x16	047	401140004	Washer $\phi 8$
004	LST-A005	Control Faceplate	048	401022076	Cap Screw M8x16
005	401032008	Button Head Screw M4x8	049	LST-A006	Cover
006	401022105	Cap Screw M10x30	050	401032029	Button Head Screw M6x10
007	401150005	Lock Washer $\phi 10$	051	ST-C001A	Cover
008	RH-2040	Washer	052	415071102	Encoder HSK-200-2
009	LST-A002A	Sliding Base	053	401022053	Cap Screw M6x16
010	LST-A003	Sliding Base	054	401150003	Lock Washer $\phi 6$
011	401010038	Hex Head Bolt M10x35	055	401140003	Washer $\phi 6$
012	401101006	Hex Nut M10	056	ST-405-105	Fixed Board
013	401042107	Phillips Head Screw M5x8	057	401042012	Phillips Head Screw M4x8
014	401140002	Washer $\phi 5$	058	ST-405-104	Gear
015	401140003	Washer $\phi 6$	059	401072033	Setscrew M6x6
016	401150003	Lock Washer $\phi 6$	060	401260004	Adjust Base BD-100
017	401032029	Button Head Screw M6x10	061	401101012	Hex Nut M16
018	LST-A013	Fixed Board CE	062	LST-A017	Foundation Bolt
019	416040005	Switch ME-8104(CE)	063	401253009	Retain Ring 4
020	401010047	Hex Head Bolt	064	LST-A015	Spring
021	401101006	Hex Nut	065	LST-A012	Fixed Shaft
022	ST-J025	Adjust Base	066	LST-A007	Door
023	401101006	Hex Nut	067	402170002	Lock MS-705-3-25
024	401072069	Setscrew	068	402170003	Key MS-705-3-25
025	401151007	Washer $\phi 20$	069	402010005	Handle B45
026	401102002	Hex Nut M20	070	LST-A001	Body
027	ST-J013	Position Shaft	071	402010005	Handle B45
028	NST-433-0-0	Driving Shaft	072	401101006	Hex Nut M10
029	401251024	Retain Ring RTW-32	073	401011014	Hex Head Bolt M10x35
030	403017102	Ball Bearing 6002 LLB	074	401042015	Phillips Head Screw M4x35
031	NST-009-0-0	Fixed Base	075	401140001	Washer $\phi 4$
032	NST-437-0-0	Washer	076	ST-A009	Fixed Base
033	401022053	Cap Screw M6x16	077	401140003	Washer $\phi 6$
034	401150003	Lock Washer $\phi 6$	078	401150003	Lock Washer $\phi 6$
035	NST-434-0-0	Washer	079	401022053	Cap Screw M6x16
036	403060003	Thrust Bearing 51102	080	401022013	Cap Screw M4x10
037	NST-011-0-0	Bearing Base	081	416140002	Safety Switch EK-1-15-R
038	401230007	Key 5x5x15	083	401150001	Lock Washer $\phi 4$
039	NST-432-0-0	Washer	084	401101002	Hex Nut M4
040	401022053	Cap Screw M6x16	087	401140005	Washer $\phi 10$
041	414080001	Plug HP-22	088	402090002	Hinger CL-208
042	NST-429-0-0	Mark	089	401022028	Cap Screw M5x12
043	NST-430-0-0	Mark			
044	402070007	Knob HS40M823			

SUPPORTING ROCKER ARM

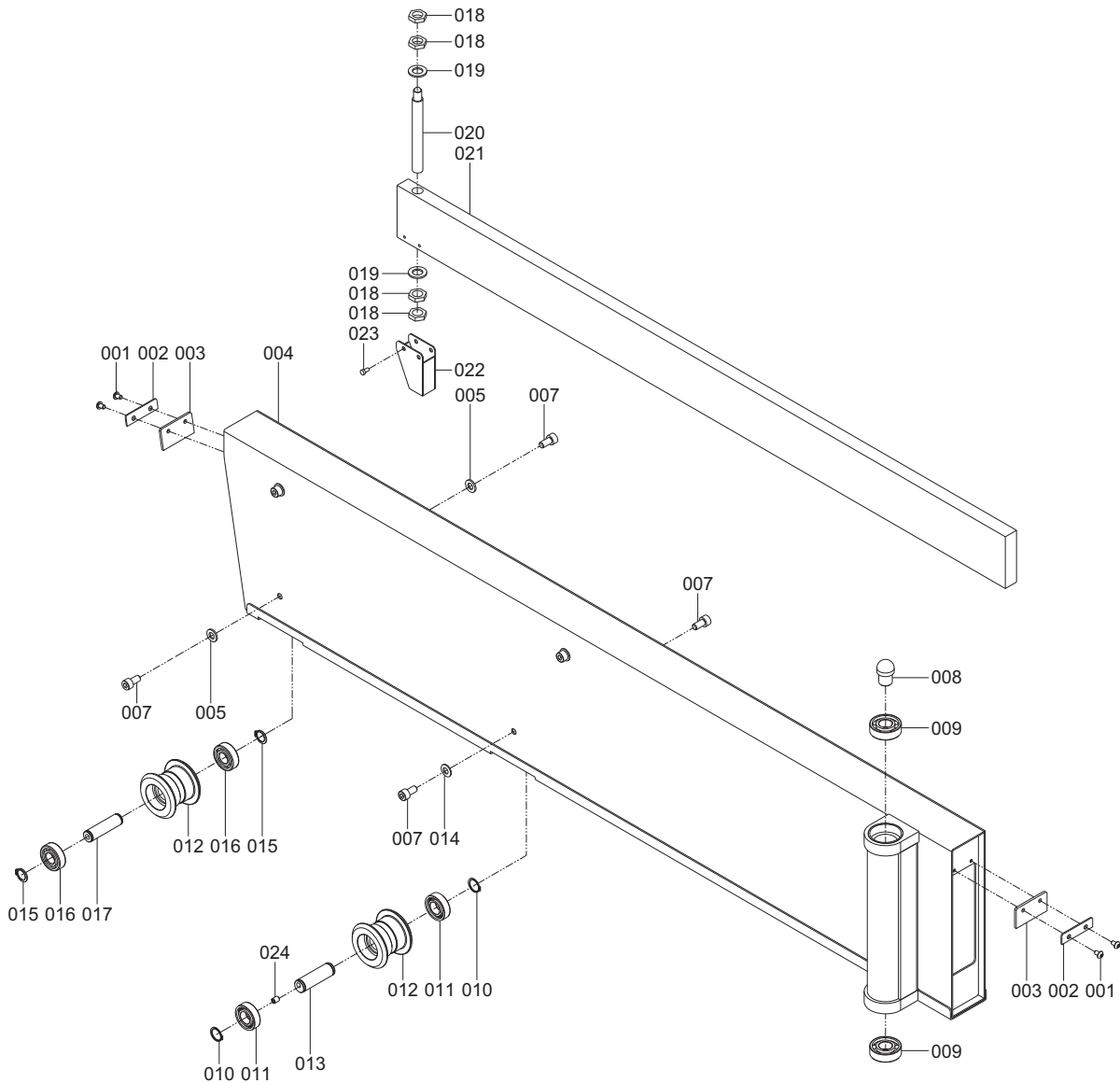

NO.	FIG. NO.	DESCRIPTION	NO.	FIG. NO.	DESCRIPTION
001	401032016	Button Head Screw M5x8	014	401151002	Washer M8
002	LST-G002	Fixed Board	015	401252010	Retain Ring STW-15
003	LST-G003	Clean Sheet	016	403013132	Ball Bearing 6202 ZZ
004	LST-G001	Arm 2.6m, 3.2m	017	ST-J015	Sliding Shaft
	LST-G001A	Arm 1.9m	018	401102002	Hex Nut M20
005	401151002	Washer M8	019	401140008	Washer ϕ 20
007	401022222	Cap Screw M8x16	020	LST-G008	Screw
008	ST-J024	Position Shaft	021	LST-G009	Extending Arm 1.9m
009	403015133	Ball Bearing 6203 LLU		LST-G009A	Extending Arm 2.6m
010	401252012	Retain Ring STW-17		LST-G009B	Extending Arm 3.2m
011	403013103	Ball Bearing 6003 ZZ	022	ST-J023B	Cover
012	ST-J014C	Sliding Wheel	023	401032029	Button Head Screw M6x10
013	LST-G004	Adjust Shaft	024	401072049	Setscrew M8x10

ROTARY BASE

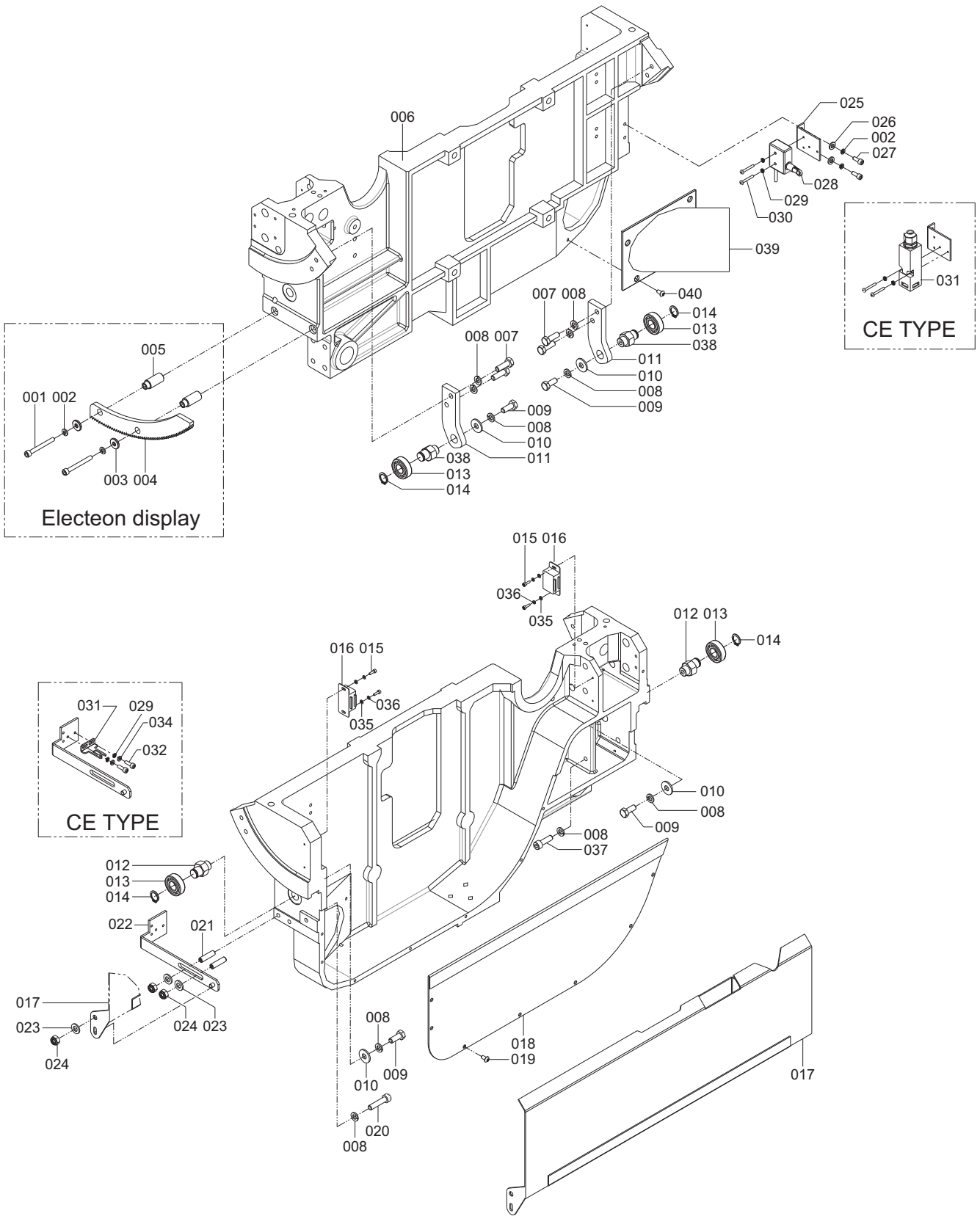

NO.	FIG. NO.	DESCRIP TION	NO.	FIG. NO.	DESCRIP TION
001	401022062	Cap Screw M6x55	021	401072055	Setscrew M8x25
002	401150003	Lock Washer $\phi 6$	022	LST-B013A	Joint Bar
003	NST-432-0-0	Washer	023	401140004	Washer $\phi 8$
004	LST-B006	Rack	024	401103001	Lock Nut M8
005	LST-B005	Fixed Pole	025	LST-B014A	Fixed Rack
006	LST-B001	Rotary Base	026	401140010	Washer $\phi 6$
007	401022080	Cap Screw M8x30	027	401022053	Cap Screw M6x16
008	401150004	Lock Washer $\phi 8$	028	416040001	Sensor TZ-7311
009	401010020	Hex Head Bolt M8x25	029	401140001	Washer $\phi 4$
010	401140016	Washer $\phi 8 \times \phi 23$	030	401042002	Phillips Head Screw M4x30
011	LST-B004	Fixed Block	031	416140002	Safety Switch EK-1-15-R
012	LST-B002	Adjust Shaft	032	401022014	Cap Screw M4x12
013	403015132	Ball Bearing 6202 2NSL	034	401150001	Lock Washer $\phi 4$
014	401252010	Retain Ring STW-15	035	401140015	Washer $\phi 3$
015	401022002	Cap Screw M3x8	036	401150010	Lock Washer $\phi 3$
016	402120004	Magnets H-22-C	037	401022079	Cap Screw M8x25
017	LST-B009	Cover	038	LST-B002A	Adjust Shaft
018	LST-B011	Coover	039	LST-B015	Collection Hole
019	401042008	Phillips Head Screw M5x8	040	401042101	Phillips Head Screw M6x12
020	401022081	Cap Screw M8x35			

6-2 SAW BLADE UNIT

MAIN SAW

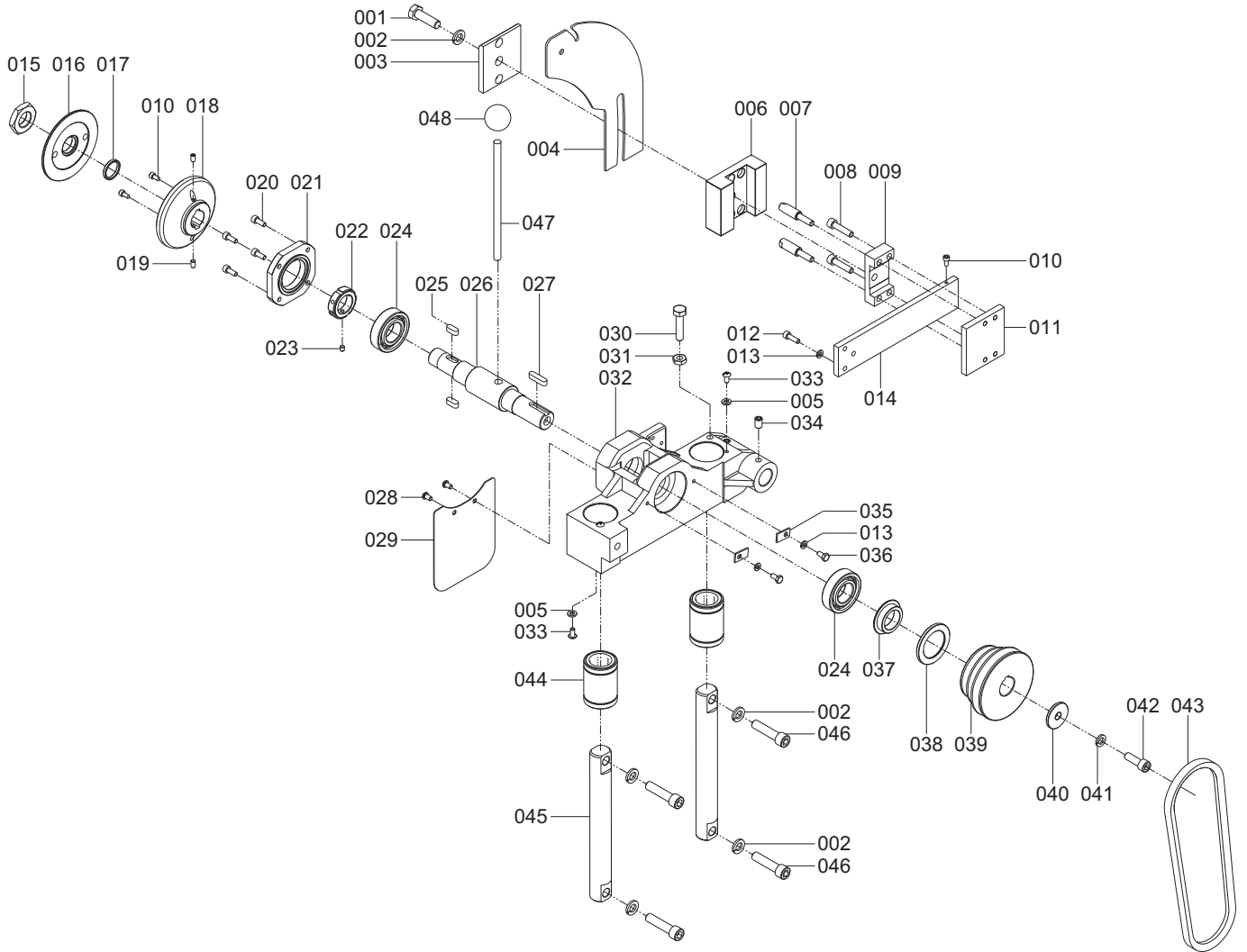

NO.	FIG. NO.	DESCRIPTION	NO.	FIG. NO.	DESCRIPTION
001	401010054	Hex Head Bolt M12x40	043	405010022	Belt 11M-750
002	401150006	Lock Washer ϕ 12		405010024	Belt 11M-800
003	ST-H086	Fixed Block	044	404020003	Line Bearing UBM-30AWW
004	LST-C029	Riving Knife(Simple) 12",14"	045	LST-B003	Sliding Rail
	ST-405-202	Riving Knife(Lux) 12",14"	046	401022131	Cap Screw M12x50
005	401140010	Washer ϕ 6x ϕ 13	047	ST-H089	Fixed Bar
006	LST-C013A	Adjust Block	048	402060002	Ball Knob 3/8"
007	ST-H087	Pin			
008	401022081	Cap Screw M8x35			
009	LST-C011	Fixed Block			
010	401022030	Cap Screw M5x16			
011	LST-C012	Fixed Block			
012	401022055	Cap Screw M6x20			
013	401150003	Lock Washer ϕ 6			
014	LST-C010	Sliding Rail 237L			
015	ST-H060A	Lock Nut			
016	ST-H064A	Shaft Cover			
017	ST-H065	Ring			
018	LST-C008	Flange ϕ 25.4			
	LST-C008A	Flange ϕ 30			
019	401072035	Setscrew M6x10			
020	401022053	Cap Screw M6x16			
021	LST-C003	Bearing Cover			
022	401110007	Exact Nut M30xP1.5-L			
023	401071033	Setscrew M6x6			
024	403010307	Ball Bearing 6206-VV-CM			
025	401230016	Key 8x7x20			
026	LST-C002	Spindle			
027	401230005	Key 8x7x32			
028	401032029	Button Head Screw M6x10			
029	LST-C009	Cover			
030	401010039	Hex Head Bolt M10x40			
031	401101006	Hex Nut M10			
032	LST-C001	Spindle Base			
033	401032030	Button Head Screw M6x12			
034	401072065	Setscrew M10x16			
035	ST-H070	Fixed Sheet			
036	401011004	Hex Head Bolt M6x12			
037	LST-C004	Bearing Cover			
038	LST-C005	Bearing Cover			
039	LST-C006A	Pulley			
040	LST-C007	Fixed Ring			
041	401150005	Lock Washer ϕ 10			
042	401022105	Cap Screw M10x30			

MAIN SAW ELEVATOR AND TILT

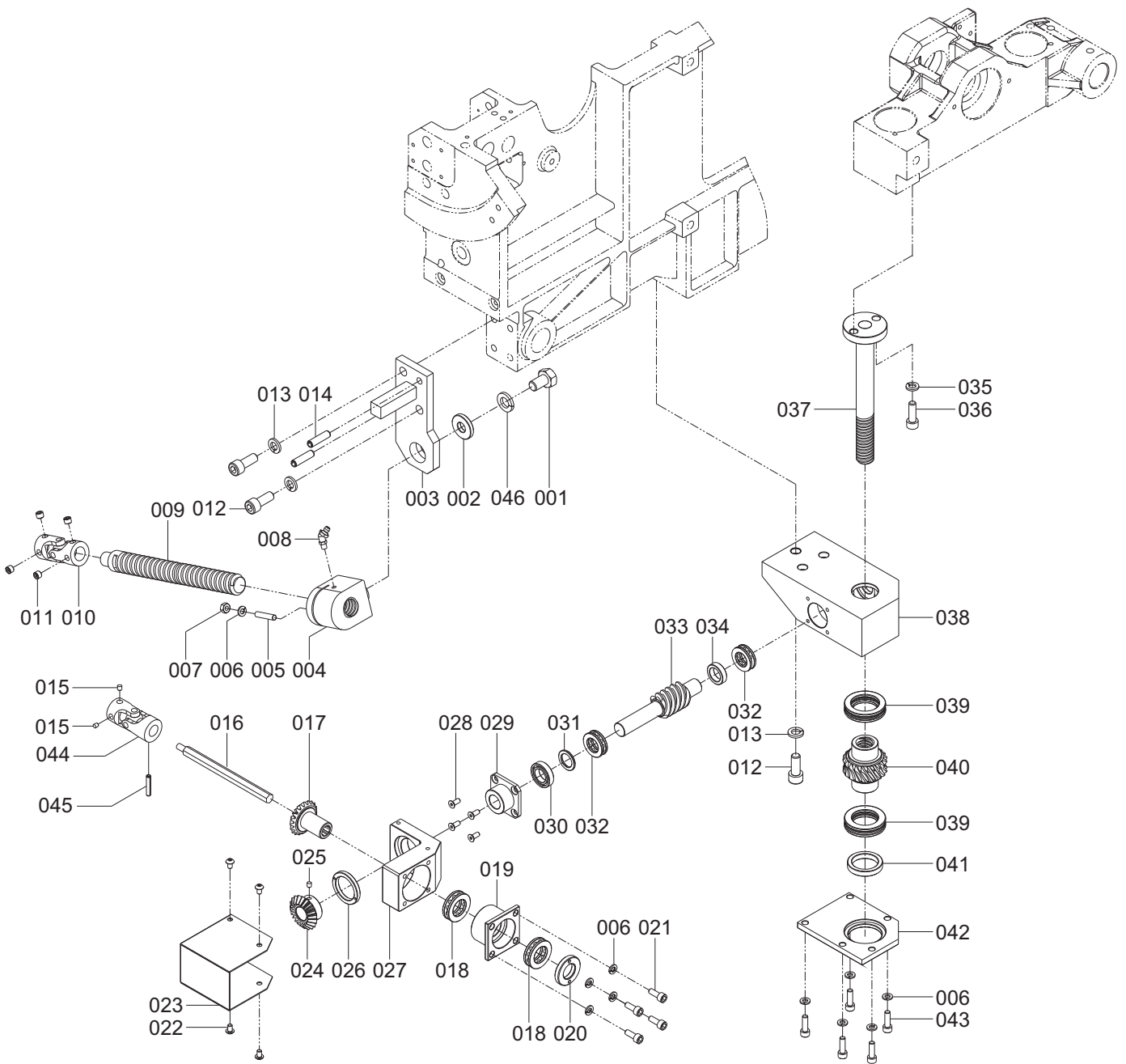

NO.	FIG. NO.	DESCRIPTION	NO.	FIG. NO.	DESCRIPTION
001	401011019	Hex Head Bolt M12x20	045	401200006	Spring Pin $\phi 6 \times 32$
002	RS-3021	Washer	046	401150006	Lock Washer $\phi 12$
003	LST-E015	Join Block			
004	NST-406-1-0	Driving Nut			
005	401072042	Setscrew M6x30			
006	401150003	Lock Washer $\phi 6$			
007	401101004	Hex Nut M6			
008	410030002	Lubricant Plug 45"-M6x10			
009	NST-401-0-0	Driving Nut			
010	NST-404-0-0	Join Shaft			
011	401072047	Setscrew M8x6			
012	401022104	Cap Screw M10x25			
013	401150005	Lock Washer $\phi 10$			
014	401200015	Spring Pin $\phi 8 \times 20$			
015	401072047	Setscrew M8x6			
016	LST-E001A	Driving Join Shaft			
017	LST-E012A	Gear			
018	403060001	Thrust Bearing 51104			
019	LST-E016	Bearing Base			
020	LST-E017	Nut			
021	401022053	Cap Screw M6x16			
022	401042008	Phillips Head screw M5x8			
023	LST-E013A	Cover			
024	LST-E011	Gear			
025	401072033	Setscrew M6x6			
026	LST-E010	Nut			
027	LST-E009A	Fixed Base			
028	401052118	Countersink Head Screw M5x12			
029	LST-E008	Fixed Base			
030	403017235	Ball Bearing 6903 LLB			
031	LST-E007	Washer			
032	403060002	Thrust Bearing 51103			
033	LST-E006	Worm			
034	NST-414-0-0	Spacer			
035	401150004	Lock Washer $\phi 8$			
036	401022079	Cap Screw M8x25			
037	LST-E014	Worm			
038	LST-E002	Gear Base			
039	403060009	Thrust Bearing 51106			
040	LST-E003	Worm Wheel			
041	LST-E005	Adjust Nut			
042	LST-E004	Cover			
043	401022055	Cap Screw M6x20			
044	LST-E018	Join Shaft			

SCORING SAW

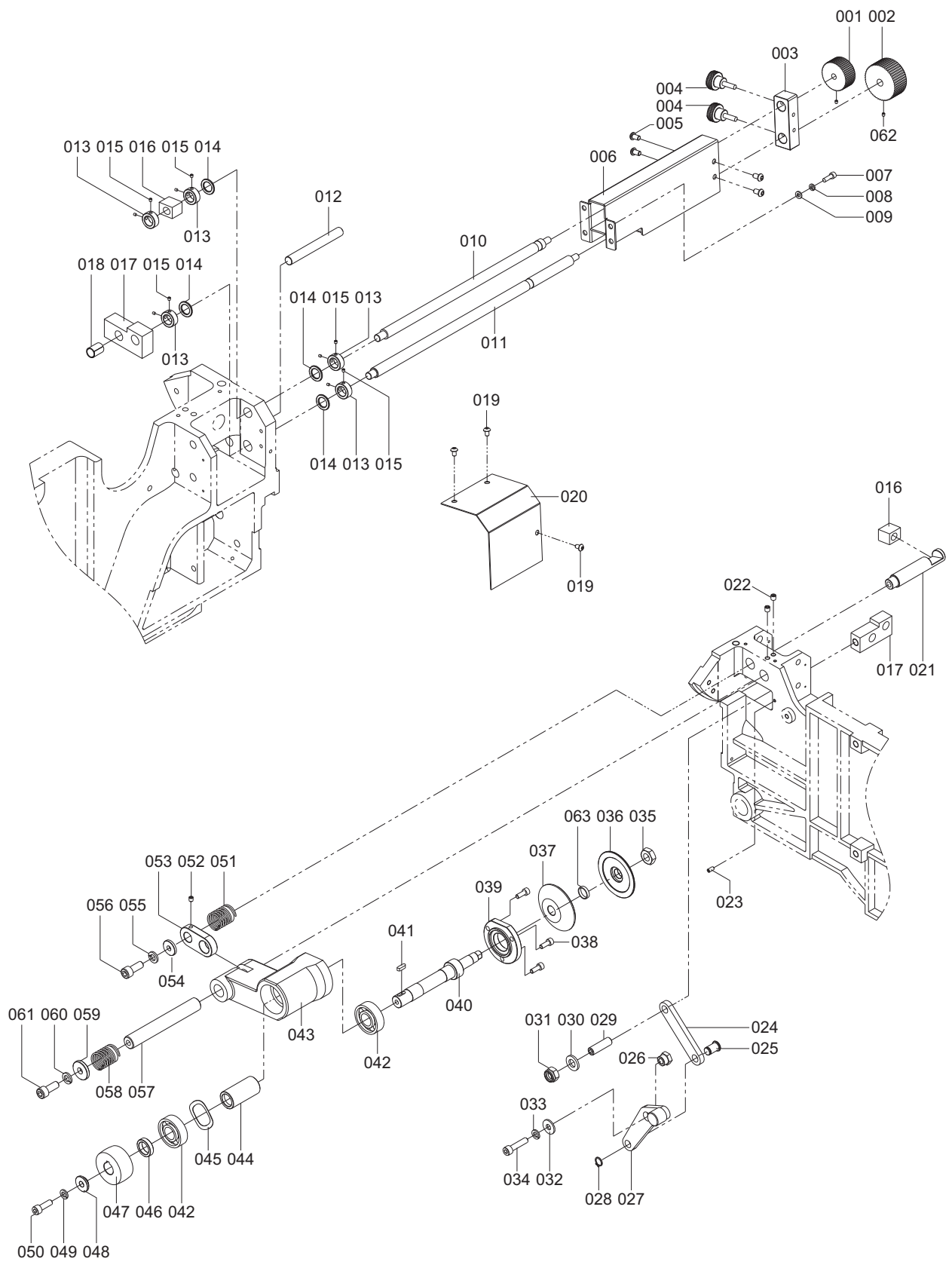

NO.	FIG. NO.	DESCRIPTION		NO.	FIG. NO.	DESCRIPTION	
1	402080007	Control Knob	7051-42-B8	42	403010305	Ball Bearing	6204-LLB-CM
2	402080008	Control Knob	7051-52-B8	43	LST-D001	Spindle Base	
3	LST-D020A	Fixed Block		44	LST-D003	Spacer	
4	402100004	Emboss Screw	8010-25-M6-20	45	411050001	Waves Spring	
5	401032029	Button Head Screw	M6x10	46	ST-I082	Spacer	
6	LST-D019A	Fixed Rack		47	ST-I048A	Pulley	
7	401022030	Cap Screw	M5x16	48	ST-I039A	Fixed Ring	
8	401150002	Lock Washer	φ5	49	401150004	Lock Washer	φ8
9	401140023	Washer	φ5	50	ST-I038A	Cap Screw	
10	LST-D008A	Adjust Shaft		51	LST-D024	Lock Washer	
11	LST-D010A	Adjust Shaft		52	401072033	Setscrew	M6x6
12	LST-D023	Sliding Rail		53	LST-B008	Driving Block	
13	LST-D014	Fixed Ring		54	LST-D006	Washer	
14	LST-D017A	Washer		55	401150005	Lock Washer	φ10
15	401072136	Setscrew	M5x4	56	401022104	Cap Screw	M10x25
16	LST-D009	Sliding Block		57	LST-D004	Pivot Axis	
17	LST-D022A	Sliding Block		58	LST-D034	Spring	
18	403090016	Bush	MB1220	59	RH-2040	Washer	
19	401032016	Button Head Screw	M5x8	60	401150005	Lock Washer	φ10
20	LST-B010	Cover		61	401022104	Cap Screw	M10x25
21	LST-B007	Driving Shaft		62	401072033	Setscrew	M5x10
22	401072054	Setscrew	M8x20	63	ST-I049	Spacer	φ19.5x13t
23	401072025	Setscrew	M5x10		ST-I049A	Spacer	φ20x13t, φ20x15t
24	NST-314-0-0	Join Arm					
25	NST-315-0-0	Pivot Axis					
26	NST-317-0-0	Pivot Axis					
27	LST-D018	Elbow					
28	401252007	Retain Ring	STW-12				
29	401072083	Setscrew	M12x40				
30	401140014	Washer	φ12				
31	401103003	Lock Nut	M12				
32	401140016	Washer	φ8x23				
33	401150004	Lock Washer	φ8				
34	401022080	Cap Screw	M8x30				
35	401102008	Hex Nut	M14xP1.5				
36	ST-I047	Cover					
37	ST-I046	Cover	φ22x13t				
	ST-I046A	Cover	φ19.5x13t				
	ST-I046B	Cover	φ20x15t				
	ST-I046C	Cover	φ20x13t				
38	401022053	Cap Screw	M6x16				
39	NST-321-0-0	Cover					
40	LST-D002	Spindle					
41	401230008	Key	6x6x15				

6-3 MOTOR UNIT

MAIN SAW MOTOR

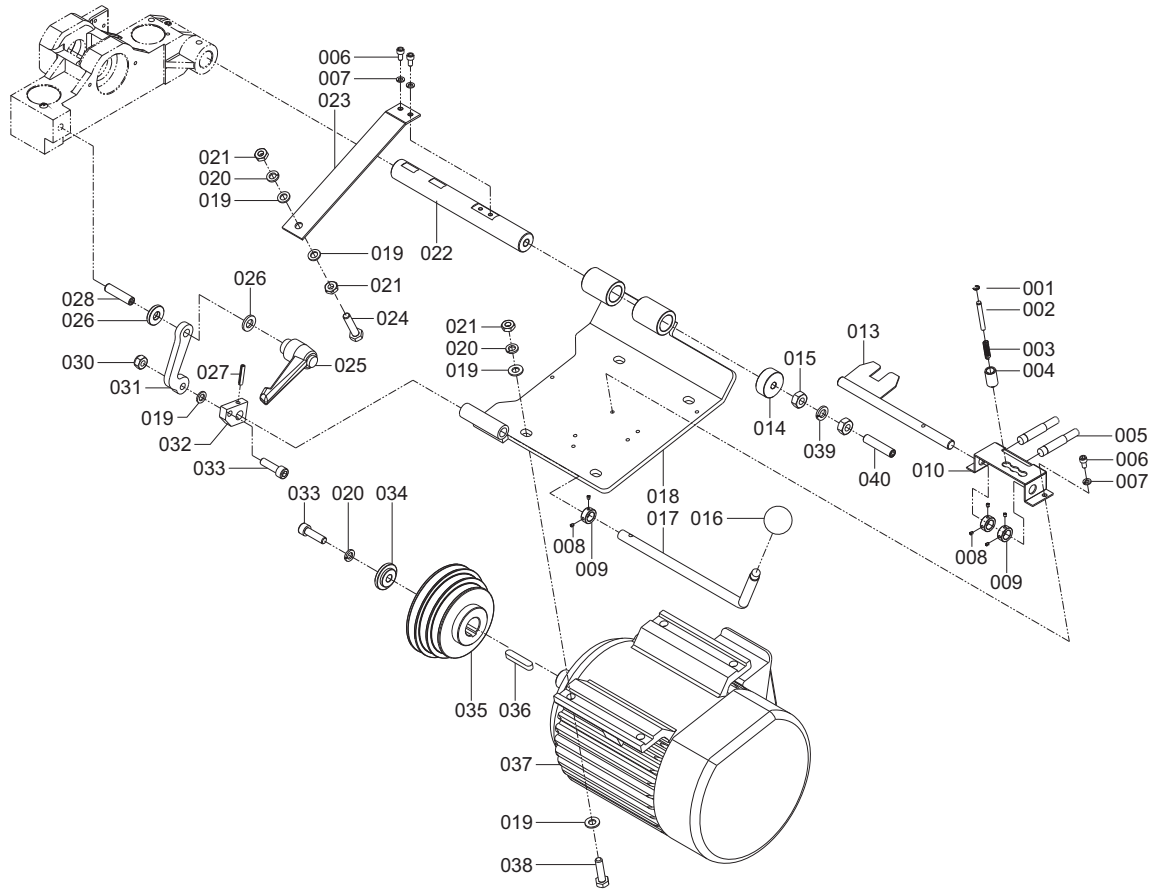

NO.	FIG. NO.	DESCRIPTION	NO.	FIG. NO.	DESCRIPTION
001	401253009	Retain Ring $\phi 4$	021	401101006	Hex Nut M10
002	LST-C024	Position Shaft	022	LST-C015A	Pivot Axis
003	LST-C028	Spring	023	LST-C026	Spring Sheet
004	LST-C025	Bush	024	401010039	Hex Head Bolt M10x40
005	416031002	Sensor PM08-02N-3m	025	402040006	Adjust Handle 95KA-M12-0
006	401022051	Cap Screw M6x12	026	401140014	Washer $\phi 12$
007	401150003	Lock Washer $\phi 6$	027	401200006	Spring Pin $\phi 6 \times 32$
008	401072033	Setscrew M6x6	028	401072085	Setscrew M12x50
009	LST-D014	Position Ring	030	401103002	Lock Nut M10
010	LST-C027	Fixed Base	031	LST-C018	Elbow
011	LST-C023	Position Board	032	LST-C019	Rotary Block
012	401032016	Button Head Screw M5x8	033	401022016	Cap Screw M10x35
013	LST-C022	Cahang Shaft	034	ST-G060	Fixed Ring
014	401072048	Setscrew M8x8	035	LST-C017	Pulley
015	401101007	Hex Nut M12	036	401230002	Key 10x8x50
016	402060006	Ball Knob 1/2"	037		Motor
017	LST-C020	Adjust Handle	038	401040039	Hex Head Bolt M10x40
018	LST-C016A	Motor Board	039	401150006	Lock Washer $\phi 12$
019	401140005	Washer $\phi 10$	040	401072085	Setscrew M12x50
020	401150005	Lock Washer $\phi 10$			

SCORING SAW MOTOR

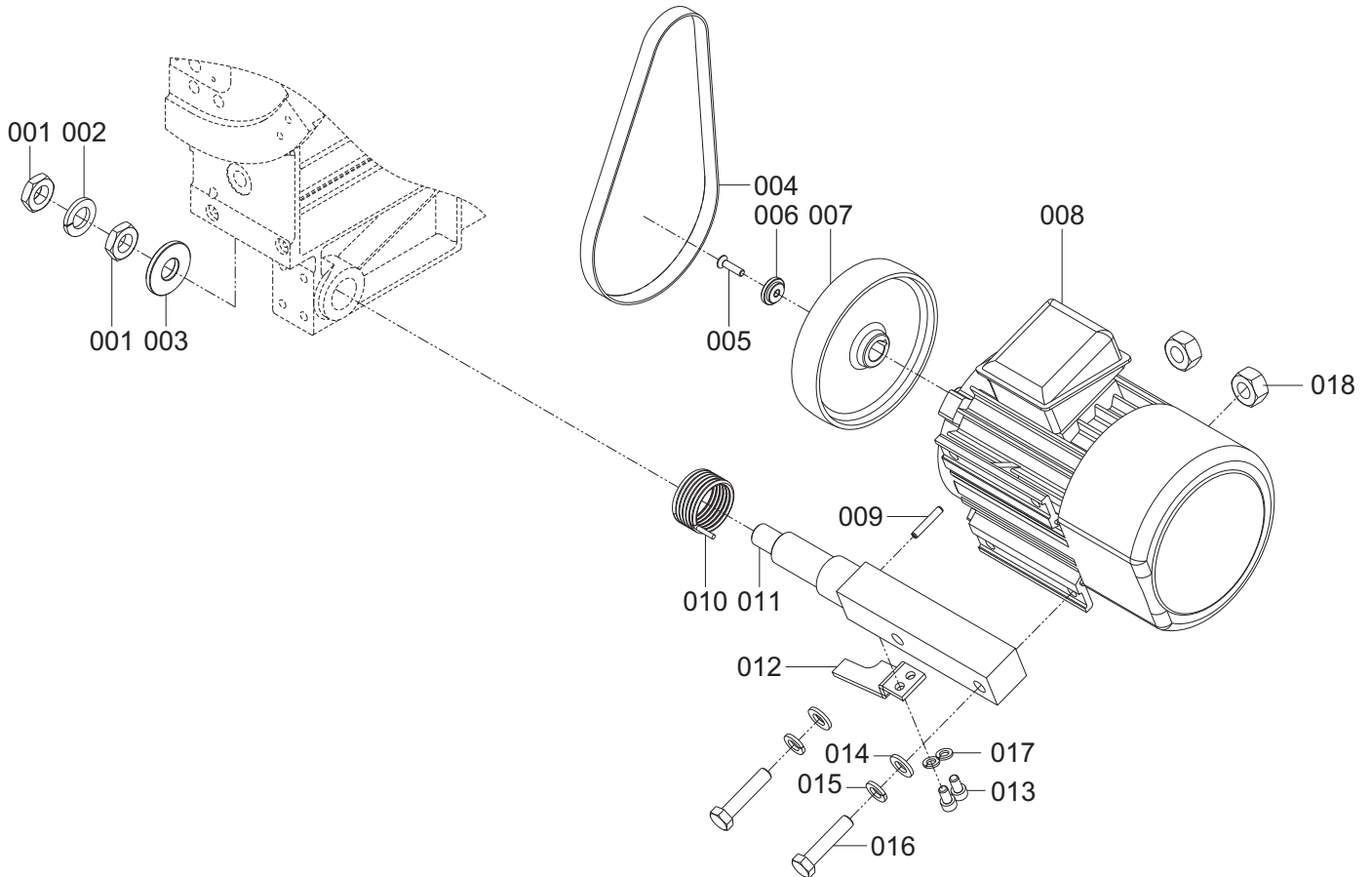

NO.	FIG. NO.	DESCRIPTION	NO.	FIG. NO.	DESCRIPTION
001	401101010	Hex Nut M20	010	NST-104-0-0	Spring
002	401150009	Lock Washer $\phi 20$	011	LST-D005	Pivot Axis
003	LST-D007	Washer	012	LST-D025	Stop Board
004	405040003	Belt 15x690x1.8t	013	401022076	Cap Screw M8x16
005	401052131	Countersink Head Screw M6x16	014	401140014	Washer $\phi 12$
006	ST-I040	Fixed Ring	015	401150006	Lock Washer $\phi 12$
007	ST-I032	Pulley	016	401011023	Hex Head Bolt M12x55
008		Motor	017	401150004	Lock Washer $\phi 8$
009	401200006	Spring Pin $\phi 6 \times 32$	018	401101007	Hex Nut M12

6-4 TABLE UNIT

MAIN TABLE

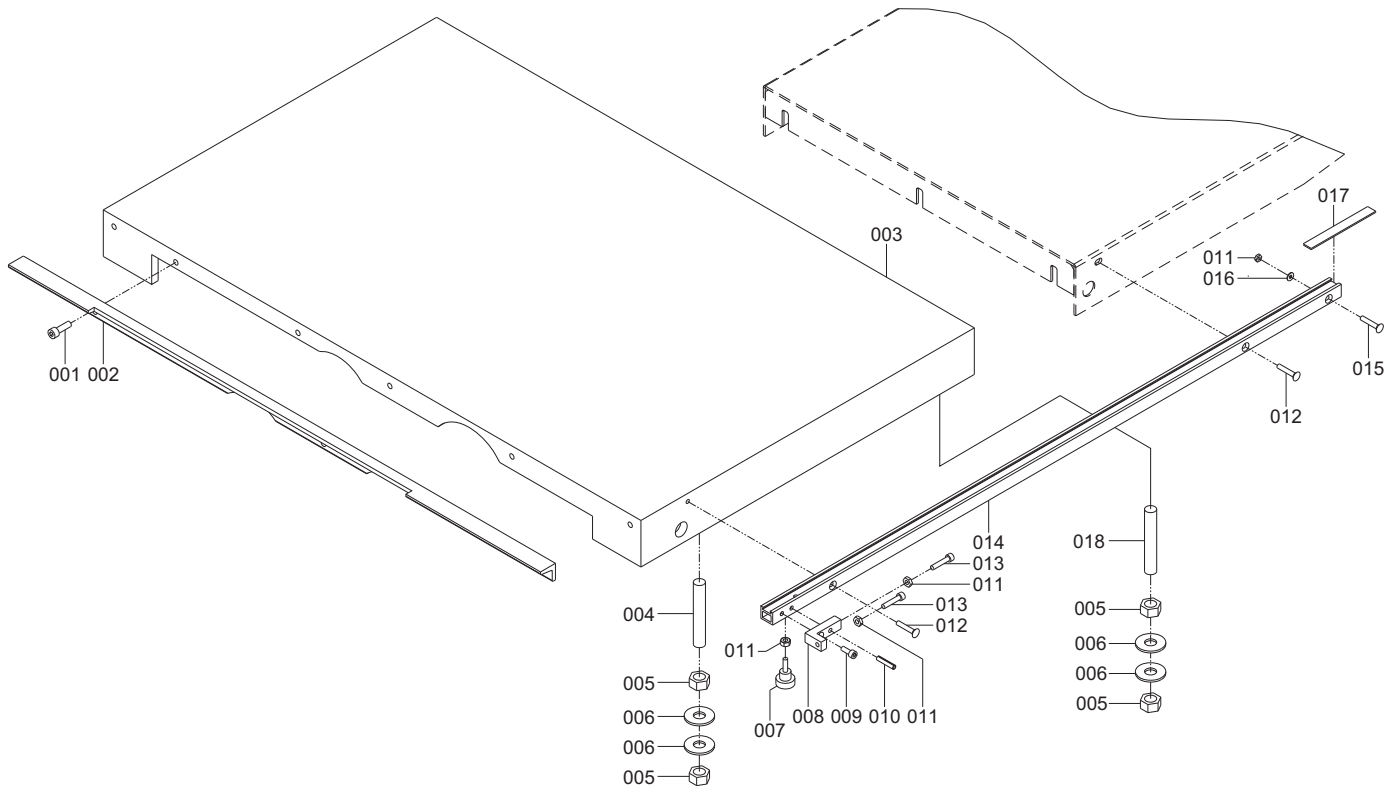

NO.	FIG. NO.	DESCRIPTION	NO.	FIG. NO.	DESCRIPTION
001	401022078	Cap Screw M8x20	013	401022057	Cap Screw M6x30
002	LST-F003	Protac Bar	014	ST-O016	Scale Base 1m
003	LST-F001	Main Table		ST-O016A	Scale Base 1.3m
004	401072130	Setscrew M16x120		ST-O016B	Scale Base 1.5m
005	401101012	Hex Nut M16	015	401052135	Countersink Head Screw M6x35
006	401140020	Washer M16	016	401140003	Washer M6
007	402100001	Emboss Screw	017	ST-N028B	Scale 1m
008	ST-O026	Fixed Block		ST-N028A	Scale 1.3m, 1.5m
009	401022053	Cap Screw M6x16		ST-N063A	Scale 1.3m, 1.5m
010	401200006	Spring Pin $\phi 6 \times 32$		ST-N063B	Scale 1m
011	401101004	Hex Nut M6	018	401072131	Setscrew M16x150
012	401052134	Countersink Head Screw M6x30			

SLIDING TABLE

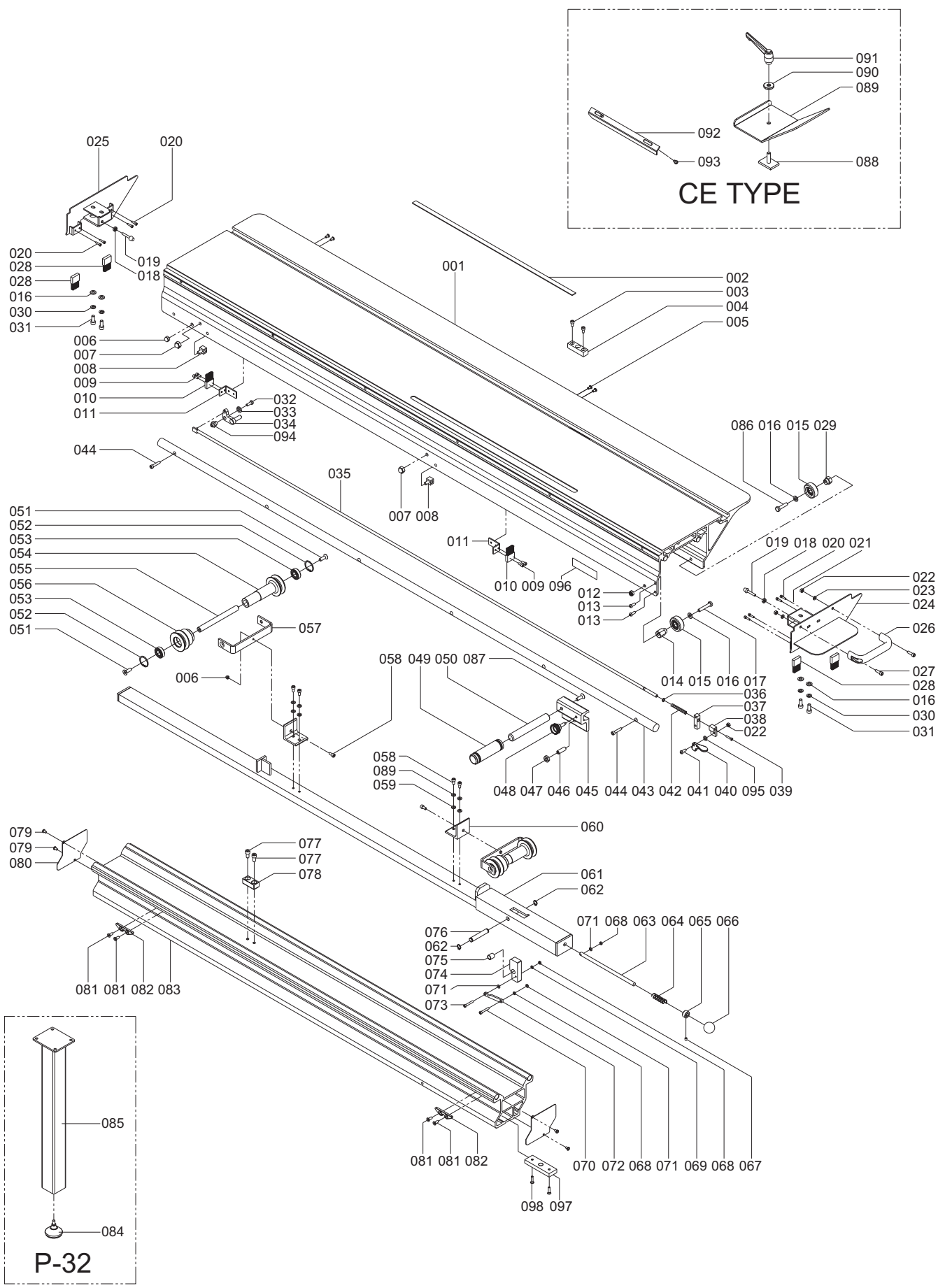

NO.	FIG. NO.	DESCRIPTION	NO.	FIG. NO.	DESCRIPTION
001	ST-K301E	Sliding Table 1.9m	042	ST-K317	Spring
	ST-K301D	Sliding Table 2.6m	043	ST-K204C	Slide Rail 1.9m
	ST-K301B	Sliding Table 3.2m		ST-K204B	Slide Rail 2.6m
002	ST-K010	Scale		ST-K204	Slide Rail 3.2m
003	401022053	Cap Screw M6x16	044	401022057	Cap Screw M6x30
004	ST-L007	Position Block	045	ST-K003A	Fixed Block
005	401032030	Button Head Screw M6x12	046	RS-4025	Screw
006	401103005	Lock Nut M6	047	401101006	Hex Nut M10
007	401104003	Cap Nut M8	048	402100002	Emboss Screw 8010-30-M8-20
008	ST-K311	Fixed Pillar	049	402010011	Handle Sleeve
009	401022028	Cap Screw M5x12	050	ST-K004	Handle
010	ST-K031B	Bristle Brush	051	401052129	Counersink Head Screw M6x12
011	ST-K034	Bristle Brush Base	052	401251024	Retain Ring RTW-32
012	401103001	Lock Nut M8	053	403017102	Ball Bearing 6002 LLB
013	401032032	Button Head Screw M6x16	054	ST-K094	Slide Wheel
014	ST-K044A	Adjust Block	055	ST-K096	Slide Wheel Shaft
015	ST-K043A	Sliding Wheel	056	ST-K095	Slide Wheel
016	401140004	Washer $\phi 8$	057	ST-K097A	Slide Wheel Base
017	401010025	Hex Head Bolt M8x45	058	401010009	Hex Head Bolt M5x20
018	401101005	Hex Nut M8	059	401140003	Washer $\phi 6$
019	402160002	Stop Screw SSP-FC-806312	060	ST-K098A	Fixed Base
020	401022013	Cap Screw M4x10	061	ST-K203C	Slide Bar 1.9m
022	401101004	Hex Nut M6		ST-K203B	Slide Bar 2.6m
023	401150003	Lock Washer $\phi 6$		ST-K203	Slide Bar 3.2m
024	ST-K305	Cover	062	401252007	Retain Ring STW-12
025	ST-K306	Cover	063	ST-K080	Pull Bar
026	402020001	Handle	064	ST-K082	Spring
027	401022055	Cap Screw M6x20	065	ST-K083	Fixed Ring
028	ST-K031	Bristle Brish	066	402060005	Knob
029	ST-K044	Adjust Block	067	401072033	Setscrew M6x6
030	401151002	Washer	068	401101003	Hex Nut M5
031	401022078	Cap Screw M8x20	069	401150002	Lock Washer $\phi 5$
032	401022057	Cap Screw M6x30	070	401022034	Cap Screw M5x30
033	401140003	Washer $\phi 6$	071	401140002	Washer $\phi 5$
034	ST-K313A	Connect Block	072	ST-K073	Join Sheet
035	ST-K323D	Connect Bar 1.9m	073	401022034	Cap Screw M5x30
	ST-K323C	Connect Bar 2.6m	074	ST-K069A	Stop Block
	ST-K323A	Connect Bar 3.2m	075	403090001	Bush MB1215
036	401253012	Retain Ring $\phi 6$	076	ST-K071	Fixed Shaft
037	ST-K309A	Fixed Block	077	401022076	Cap Screw M8x16
038	ST-K308A	Stop Block	078	ST-K041A	Stop Block
039	401022013	Cap Screw M4x10	079	401042008	Phillips Head Screw M5x8
040	ST-K307A	Handle	080	ST-K320	Cover
041	401032033	Button Head Screw M6x20	081	401052129	Counersink Head Screw M6x12

NO.	FIG. NO.	DESCRIPTION	
082	ST-K316	Position Block	
083	ST-K302E	Support Base	1.9m
	ST-K302D	Support Base	2.6m
	ST-K302B	Support Base	3.2m
084	401260003	Pedestal	
085	ST-K207	Support Scaffold	
086	401010022	Hex Head Bolt	M8x35
087	401052143	Countersink Head Screw	M8x25
088	ST-L011	T-Shape Block	CE
089	ST-L029	Stop Board	CE
090	RH-2040	Washer	
091	402040008	Adjust Handle	DA7012-A10x95-B
092	ST-K318	Touch Block	CE
093	401032030	Button Head Screw	M6x12
094	ST-K312	Pivot Axis	
095	ST-K322	Washer	
096	ST-K321	Mark	
097	ST-K002	Lock Block	
098	401052131	Countersink Head Screw	M6x16
099	401010008	Hex Head Bolt	M6x16

CROSSCUT TABLE

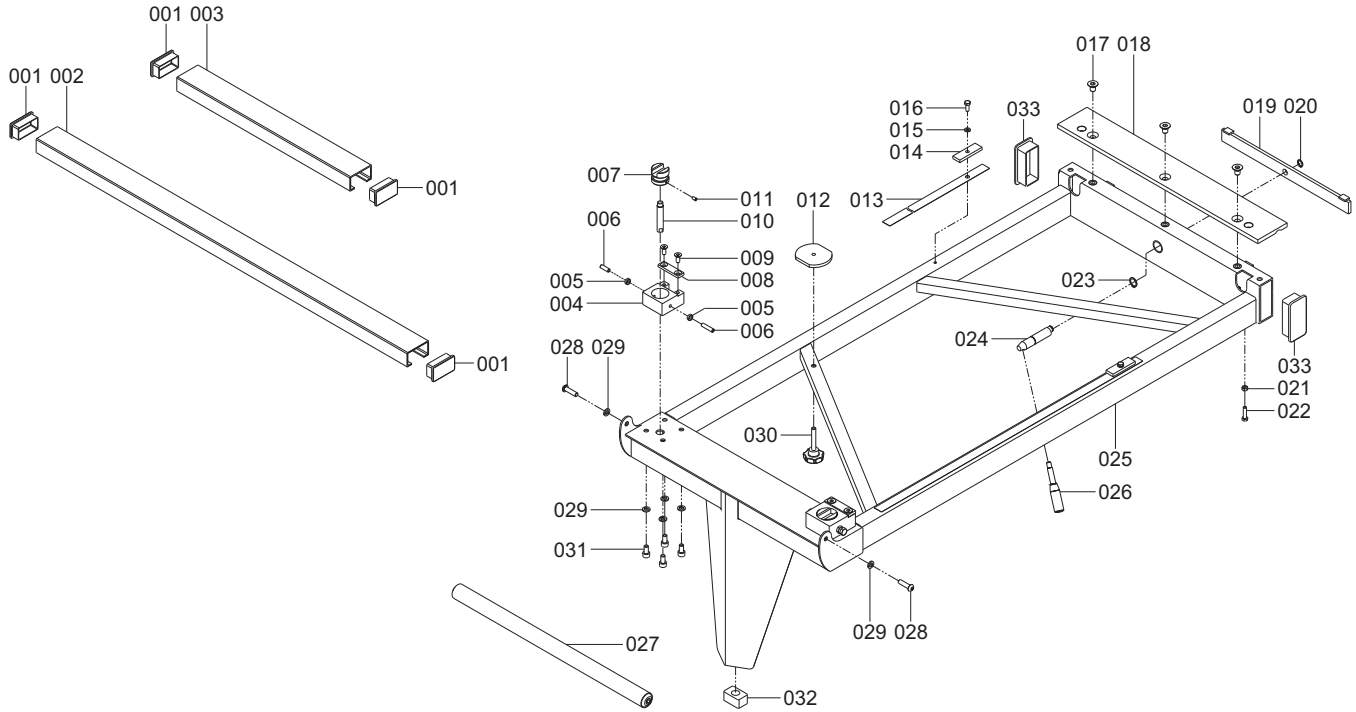

NO.	FIG. NO.	DESCRIPTION	NO.	FIG. NO.	DESCRIPTION
001	ST-M017	Rectangle Insert	018	ST-M002A	Fixed Board
002	ST-M019	Short	019	ST-M006	Lock Bar
003	ST-M018	Short	020	401252009	Retain Ring STW-14
004	ST-M022B	Fixed Base	021	401101004	Hex Nut M6
005	401101005	Hex Nut M8	022	401072038	Setscrew M6x16
006	401072057	Setscrew M8x35	023	401252015	Retain Ring STW-20
007	ST-M028A	Adjust Block	024	ST-M005	Fixed Shaft
008	ST-M023	Clamp Element	025	LST-G005	Crosscut Table 2.6m, 3.2m
009	401052139	Countersink Head Screw M8x12		LST-G005A	Crosscut Table 1.9m
010	ST-M029	Screw	026	402010002	Handle
011	401072035	Setscrew M6x10	027	403140001	Roller M8x15
012	ST-M020	Fixed Sheet	028	401032043	Button Head Screw M8x16
013	ST-N095	Avert Friction Sheet 2.6m, 3.2m	029	401150004	Lock Washer φ8
	ST-N095A	Avert Friction Sheet 1.9m	030	402070005	Knob Bolt 3/8"-16
014	ST-M016	Fixed Board	031	401022076	Cap Screw M8x16
015	401150003	Lock Washer φ6	032	NST-713-0-0	Fixed Block
016	401010008	Hex Head Bolt M6x16	033	ST-M037	Retain Insert
017	401052152	Countersink Head Screw M10x25			

EXTENSION TABLE

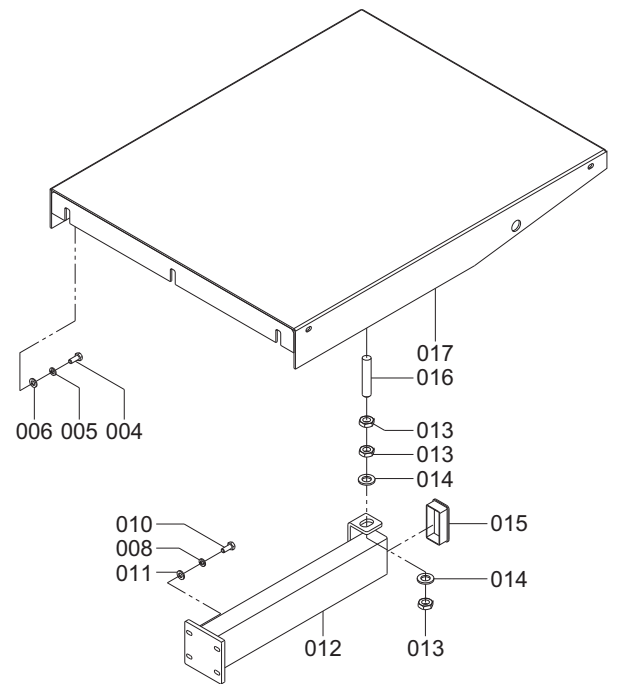
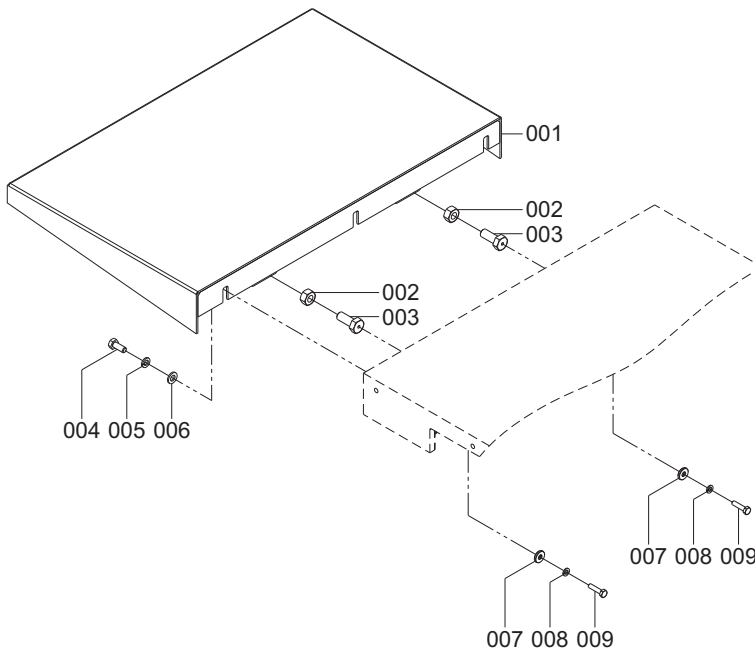

NO.	FIG. NO.	DESCRIPTION		NO.	FIG. NO.	DESCRIPTION	
001	LST-F011A	Table Extension	Normal	011	401140010	Washer	φ6
	LST-F011	Table Extension	CE	012	LST-F015	Support Rack	1m
002	401101007	Hex Nut	M12		LST-F015A	Support Rack	1.3、1.5m
003	ST405-505	Hex Head Bolt		013	401102001	Hex Nut	M16
004	401010019	Hex Head Bolt	M8x20	014	401140022	Washer	φ12
005	401151002	Washer	φ8	015	402130001	Square Pipe Plug	40x80x3t
006	401140004	Washer	φ8	016	401072110	Setscrew	M16x35
007	NST-432-0-0	Washer		017	LST-F014A	Width Extension	1m
008	401150002	Lock Washer	φ5		LST-F014B	Width Extension	1.3m
009	401022033	Cap Screw	M5x25		LST-F014C	Width Extension	1.5m
010	401010009	Hex Head Bolt	M6x20				

6-5 FENCE UNIT

RIP FENCE

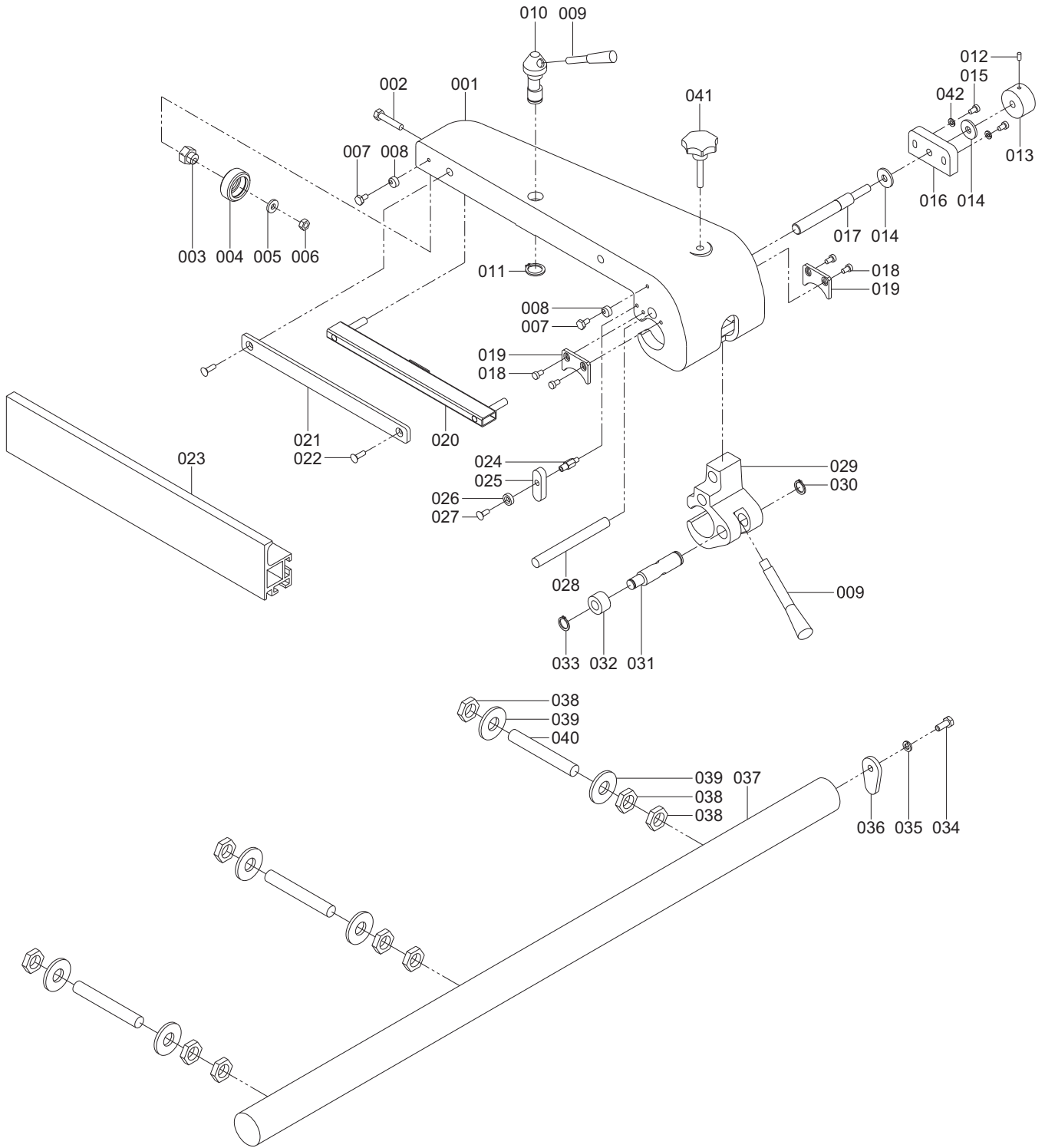

NO.	FIG. NO.	DESCRIPTION	NO.	FIG. NO.	DESCRIPTION
001	LST-F004	Fixed Base	023	ST-Q014	Rip Fence
002	401010023	Hex Head Bolt M8x40	024	ST-Q035	Screw
003	ST-K044	Adjust Block	025	LST-F009	Guide Key
004	ST-K043A	Slide Wheel	026	ST-Q033	Fixed Ring
005	401140004	Washer $\phi 8$	027	401052118	Countersink Head Screw M5x12
006	401103001	Lock Washer M8	028	LST-F007	Slide Rail
007	401010008	Hex Head Bolt M6x16	029	LST-F005	Slide base
008	ST-Q002	Guide Wheel	030	401252013	Retain Ring STW-18
009	402010003	Handle 1162-M12-125	031	LST-F010	Fixed Shaft
010	ST-Q011A	Fixed Shaft	032	ST-Q038	Lockring
011	401252015	Retain Ring STW-20	033	401252009	Retain Ring STW-14
012	401072025	Setscrew M5x10	034	401010019	Hex Head Bolt M8x20
013	402080003	Control Knob 7021-40-B12	035	401150004	Lock Washer $\phi 8$
014	ST-Q027	Washer	036	ST-Q077	Stop Block
015	401022055	Cap Screw M6x20	037	LST-F002	Slide Rail 1m
016	LST-F006	Fixed Base		LST-F002A	Slide Rail 1.3m
017	ST-Q026	Adjust Shaft		LST-F002B	Slide Rail 1.5m
018	401032029	Button Head Screw M6x10	038	401102001	Hex Nut M16
019	LST-F008	Dust Scraper	039	401140020	Washer $\phi 16$
020	ST-Q010	Lashing Bar	040	401072135	Setscrew M16x130
021	ST-Q005	Lashing Plate	041	402070006	Knob HS50AM103C
022	401052129	Countersink Head Screw M6x12	042	401150002	Lock Washer $\phi 6$

RIP FENCE DIGITAL DISPLAY

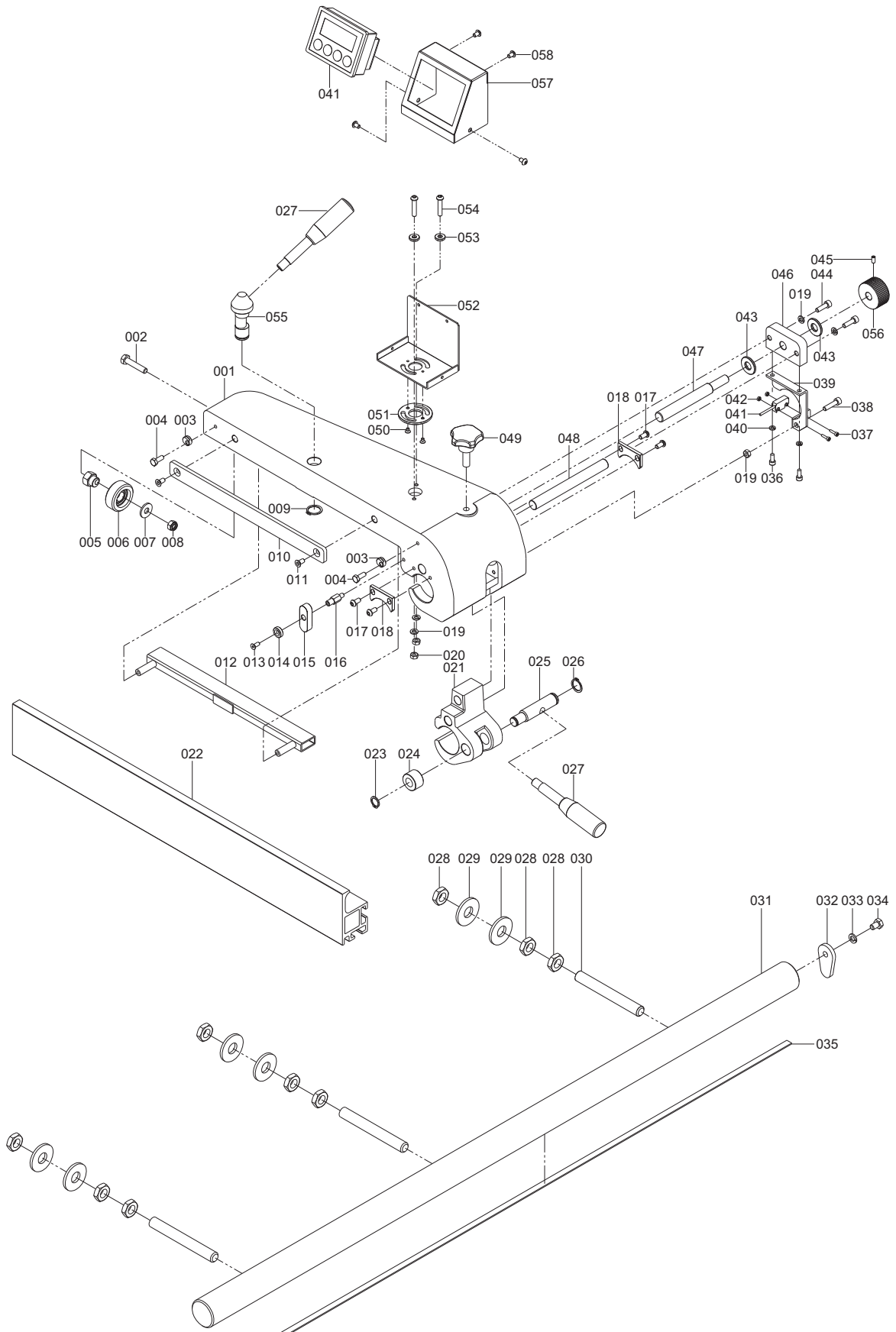

NO.	FIG. NO.	DESCRIPTION	NO.	FIG. NO.	DESCRIPTION
001	LST-F004	Fixed Base	041	415020001	Digital Display 50cm
002	401010023	Hex Head Bolt M6x40	042	401101001	Hex Nut M3
003	ST-Q002	Guide Wheel	043	ST-Q027	Washer
004	401010008	Hex Head Bolt M6x16	044	401022055	Cap Screw M6x20
005	ST-K044	Adjust Block	045	401072025	Setscrew M5x10
006	ST-K043A	Slide Wheel	046	LST-F006	Fixed Stand
007	401140028	Washer $\phi 8 \times \phi 23 \times 3t$	047	ST-Q026	Adjust Shaft
008	401103001	Lock Washer M8	048	LST-F007	Slide Rail
009	401252015	Retain Ring STW-20	049	402070006	Knob HS50AM1030
010	ST-Q005	Lashing Plate	050	401052103	Countersink Head Screw M4x6
011	401052129	Countersink Head Screw M6x12	051	LST-F017	Washer
012	ST-Q010	Lashing Plate	052	LST-F021	Cover Base
013	401052118	Countersink Head Screw M5x12	053	LST-F019	Washer
014	ST-Q033	Fixed Ring	054	401022057	Cap Screw M6x30
015	LST-F009	Guide Wheel	055	ST-Q011A	Fixed Shaft
016	ST-Q035	Hex Head Bolt	056	402080003	Control Knob 7021-42-B12
017	401032029	Button Head Screw M6x10	057	LST-F020	Cover
018	LST-F008	Dust Scraper	058	401042008	Phillips Head Screw M5x8
019	401150003	Lock Washer $\phi 6$			
020	401101004	Hex Nut M6			
021	LST-F005	Slide Base			
022	ST-Q014	Rip Fence			
023	401252009	Retain Ring STW-14			
024	ST-Q038	Lock Ring			
025	LST-F010	Fixed Shaft			
026	401252013	Retain Ring STW-18			
027	402010003	Knob 1162-M12-125			
028	401102001	Hex Nut M16			
029	401140020	Washer $\phi 16$			
030	401072135	Setscrew M16x130			
031	LST-F002C	Slide Rail 1m			
	LST-F002D	Slide Rail 1.3m			
	LST-F003E	Slide Rail 1.5m			
032	ST-Q077	Stop Block			
033	401150004	Lock Washer $\phi 8$			
034	401011015	Hex Head Bolt M8x12			
035	415020004	Magnetic Ruler 1050mm			
		Magnetic Ruler 1350mm			
		Magnetic Ruler 1550mm			
036	401022028	Cap Screw M5x12			
037	401022005	Cap Screw M3x14			
038	401022057	Cap Screw M6x30			
039	LST-F018	Fixed Stand			
040	401150002	Lock Washer $\phi 5$			

CROSSCUT FENCE

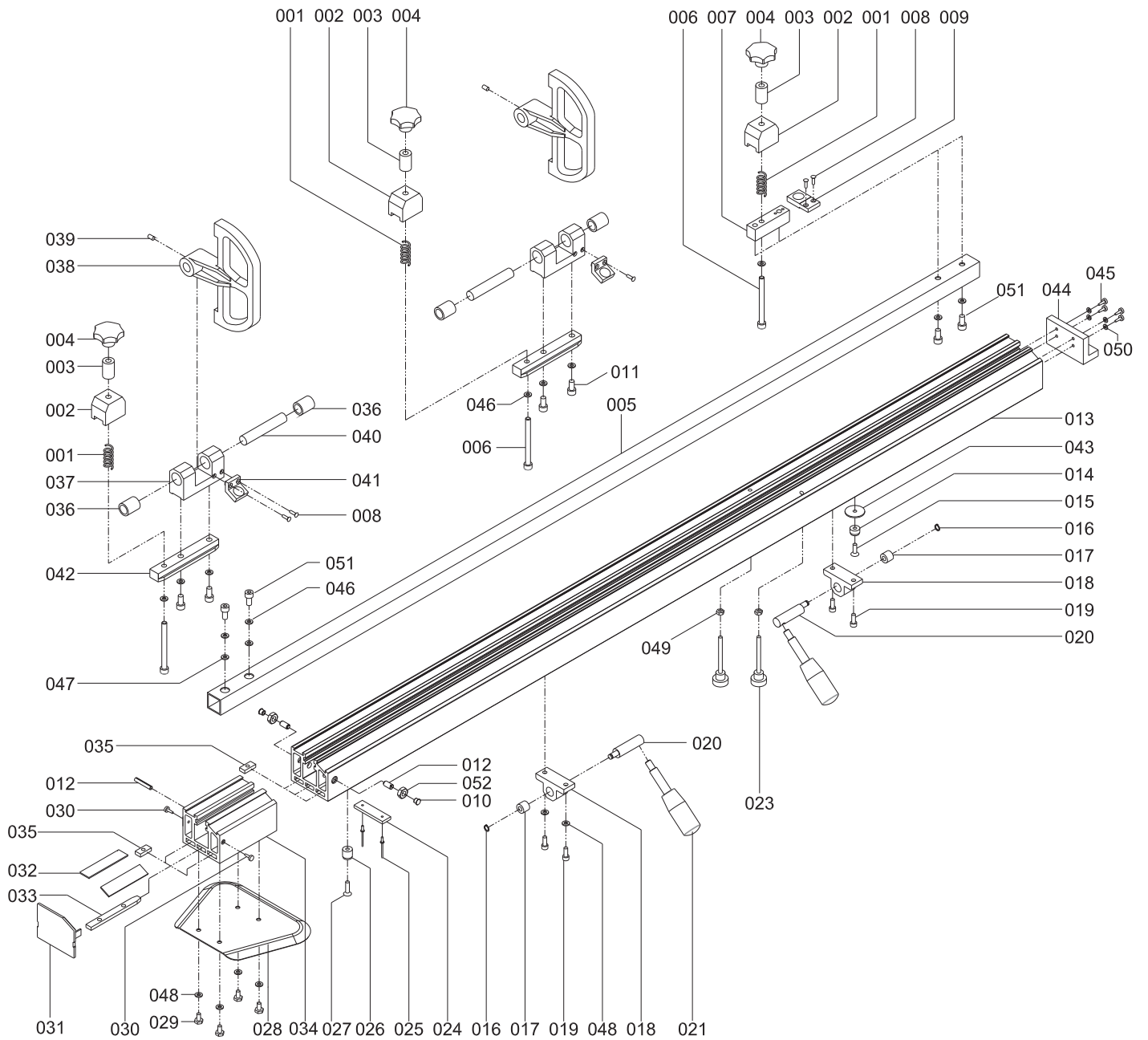

NO.	FIG. NO.	DESCRIPTION	NO.	FIG. NO.	DESCRIPTION
001	ST-N022	Spring	037	ST-N007	Adjust Block
002	ST-N013	Locking Slide Block	038	ST-N008	Positioning Plate
003	ST-N014	Locking Bush	039	401072033	Setscrew M6x6
004	402070002	Str- Shaped Knob HS50AM8	040	ST-N011	Rotary Shaft
005	ST-N006	Positioning Pipe 2.6m, 3.2m	041	ST-N053	Magnifier
	ST-N006C	Positioning Pipe 1.9m	042	ST-N027	Locking Base
006	401022092	Cap Screw M8x90	043	ST-N005	Washer
007	ST-N018	Locking Block	044	ST-N052	Lengthening Scale Block
008	401052111	Countersink Head Screw M4x4	045	401060001	Screw 1/8"x3/4"L
009	ST-N015	Magnifier	046	401150004	Lock Washer φ8
010	414080008	Hole Plug HP-09	047	401140004	Washer φ8
011	401022076	Cap Screw M8x16	048	401150003	Lock Washer φ6
012	ST-N107	Setscrew	049	401101004	Hex Nut M6
013	ST-N058	Fence Scale Base 2.6m, 3.2m	050	401140001	Washer φ4
	ST-N058C	Fence Scale Base 1.9m	051	401022078	Cap Screw M8x20
014	ST-N004	Front Positioning Pin	052	401101005	Hex Nut M8
015	401022053	Cap Screw M6x16			
016	401252003	Retainer For Shaft STW-8			
017	ST-N036	Tightening Ring			
018	ST-N035	Tightening Base			
019	401022053	Cap Screw M6x16			
020	ST-N031	Rotary Fastening Base			
021	402010002	Handle 7108-M10-100			
023	ST-N023	Embossing Screw			
024	ST-N062	Packing-Up Block			
025	401290001	Draw Nail 4-2			
026	ST-N003	Rear Positioning Pin			
027	401022055	Cap Screw M6x20			
028	ST-N054A	Butterly-Shaped Plate			
029	401010008	Hex Head Bolt M6x12			
030	401060004	Wooden Screw 1/8"x3/8"L			
031	ST-N060	Left Cover Plate			
032	ST-N028	Scale 2.6,3.2m(inch)			
	ST-N028C	Scale 2.6,3.2m(inch)			
	ST-N028D	Scale 1.9m(inch)			
	ST-N028E	Scale 1.9m(inch)			
	ST-N063	Scale 2.6,3.2m(mm)			
	ST-N063C	Scale 2.6,3.2m(mm)			
	ST-N063D	Scale 1.9m(mm)			
	ST-N063E	Scale 1.9m(mm)			
033	ST-N055	Positioning Pin			
034	ST-N061	Scale Base			
035	ST-N059	Fixing Sheet			
036	403090028	Bush MB1625			

CROSSCUT FENCE TWO DIGITAL DISPLAY

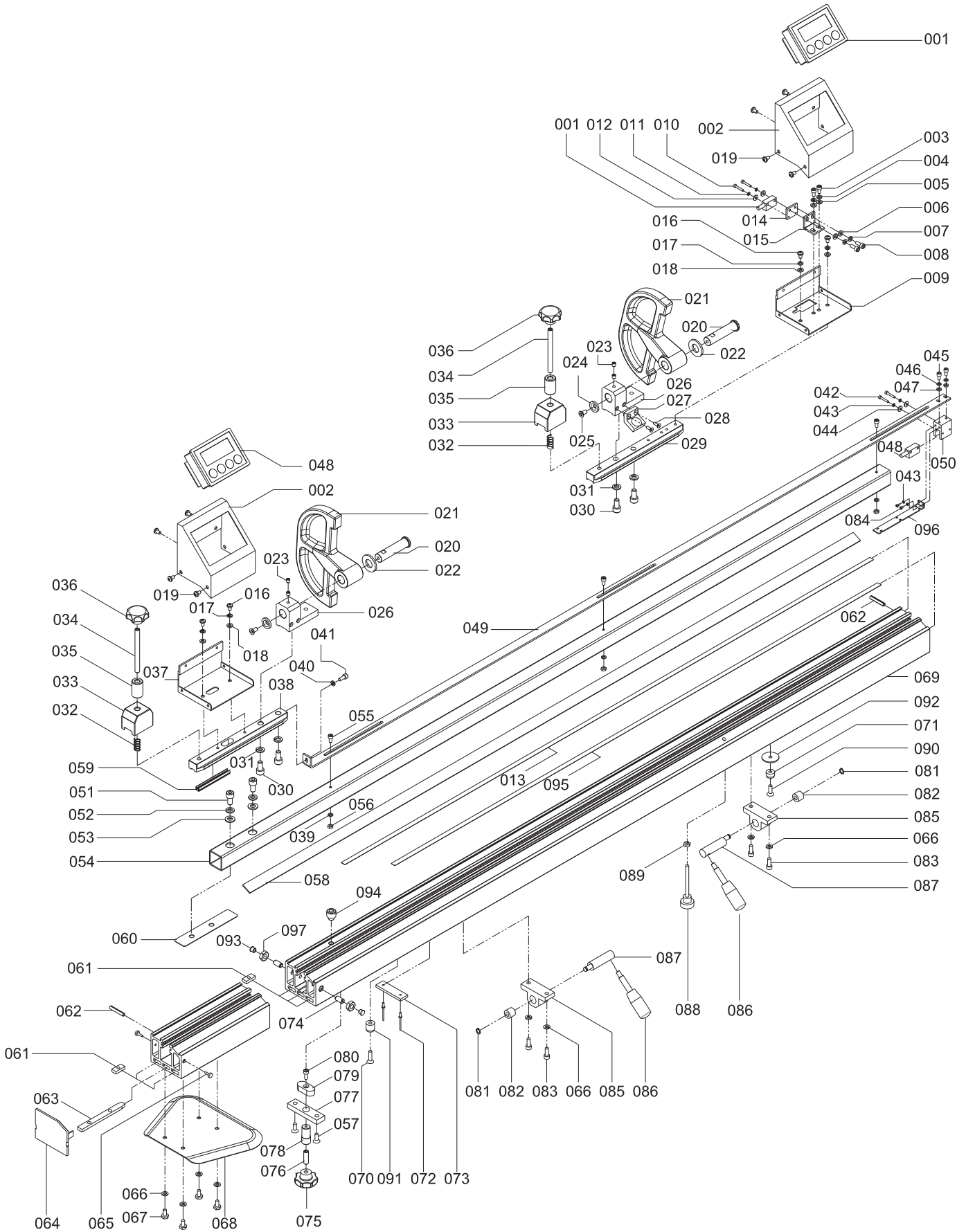

NO.	FIG. NO.	DESCRIPTION	NO.	FIG. NO.	DESCRIPTION
001	415020001	Digital Display 50cm	045	401022013	Cap Screw M4x10
002	ST-N064	Cover	046	401150001	Lock Washer $\phi 4$
003	401022028	Cap Screw M5x12	047	401140001	Washer $\phi 4$
004	401150002	Lock Washer $\phi 5$	048	415020012	Digital Display 3m
005	401140002	Washer $\phi 5$	049	ST-N102	Join Bar 2.6m, 3.2m
006	401140002	Washer $\phi 5$		ST-N102A	Join Bar 1.9m
007	401150002	Lock Washer $\phi 5$	050	ST-N103	Fixed Block
008	401022026	Cap Screw M5x8	051	401022076	Cap Screw M8x16
009	ST-N065	Cover Base	052	401150004	Lock Washer $\phi 8$
010	401022003	Cap Screw M3x10	053	401140004	Washer $\phi 8$
011	401150010	Lock Washer $\phi 3$	054	ST-N006D	Position Pipe 2.6m, 3.2m
012	401140015	Washer $\phi 3$		ST-N006E	Position Pipe 1.9m
013	415020014	Magnetic Ruler	055	401022223	Cap Screw M5x10
014	ST-N068	Fixed Board	056	401101003	Hex Nut M5
015	ST-N067	Fixed Rack	057	401052132	Countersink Head Screw M6x20
016	401022026	Cap Screw M5x8	058	ST-N028F	Scale 2.6m, 3.2m
017	401150002	Lock Washer $\phi 5$		ST-N028H	Scale 1.9m
018	401140002	Washer $\phi 5$	059	408110003	Slot Cover
019	401042008	Phillips Head Screw M5x8	060	ST-N113	Packing Up Block
020	ST-N099	Pivot Axis	061	ST-N059	Fixed Sheet 6x25x15L
021	ST-N008	Position Plate	062	401200008	Spring Pin $\phi 6 \times 40$
022	ST-N100	Washer	063	ST-N055	Position Pin
023	401072035	Setscrew M6x10	064	ST-N060	Cover
024	ST-N101	Washer	065	401060001	Wooden Screw 1/8"x3/4"L
025	401052129	Countersink Head Screw M6x12	066	401150003	Lock Washer $\phi 6$
026	ST-N073A	Fixed Base	067	401011004	Hex Head Screw M6x12
027	ST-N053	Magnifier	068	ST-N054A	Butterfly-Shaped Plate
028	401052111	Countersink Head Screw M4x14	069	ST-N058E	Fence Scale Base 2.6, 3.2m
029	ST-N066D	Lock Slide Base		ST-N058I	Fence Scale Base 1.9m
030	401022076	Cap Screw M8x16	070	401022055	Cap Screw M6x20
031	401150004	Lock Washer $\phi 8$	071	ST-N003	Position Pin
032	ST-N022	Spring	072	401290002	Draw Nail 4-3
033	ST-N013	Lock Slide Block	073	ST-N062	Packing Up Block
034	401072138	Setscrew M8x90	074	ST-N107	Setscrew
035	ST-N014	Lock Bush	075	402070002	Star-Shaped Knob M8
036	402070002	Star-Shaped Knob M8	076	401072058	Setscrew M8x40
037	ST-N065B	Cover	077	ST-N105	Fixed Block
038	ST-N066E	Lock Slide Base	078	ST-N106	Lock Screw
039	401140002	Lock Washer $\phi 5$	079	ST-N104	Fixed Block
040	401150002	Lock Washer $\phi 5$	080	401022223	Cap Screw M5x10
041	401022026	Cap Screw M5x8	081	401252003	Retain Ring STW-08
042	401022007	Cap Screw M3x18	082	ST-N036	Tighten Ring
043	401150010	Lock Washer $\phi 3$	083	401022053	Cap Screw M6x16
044	401140015	Washer $\phi 3$	084	401022003	Cap Screw M3x10

NO.	FIG. NO.	DESCRIPTION
085	ST-N035	Tightening Base
086	402010002	Handle 7108-M10-100
087	ST-N031	Rotary Fastening Base
088	ST-N023	Embossing Screw
089	401101004	Hex Nut M6
090	401022053	Cap Screw M6x16
091	ST-N004	Pin
092	ST-N005	Washer
093	414080008	Fence Scale Base HP-09
094	ST-N094	Stop Screw
095	415020013	Magnetic Ruler 1450mm
096	ST-N112	Safe Sheet
097	401101005	Hex Nut M8

MITER FENCE

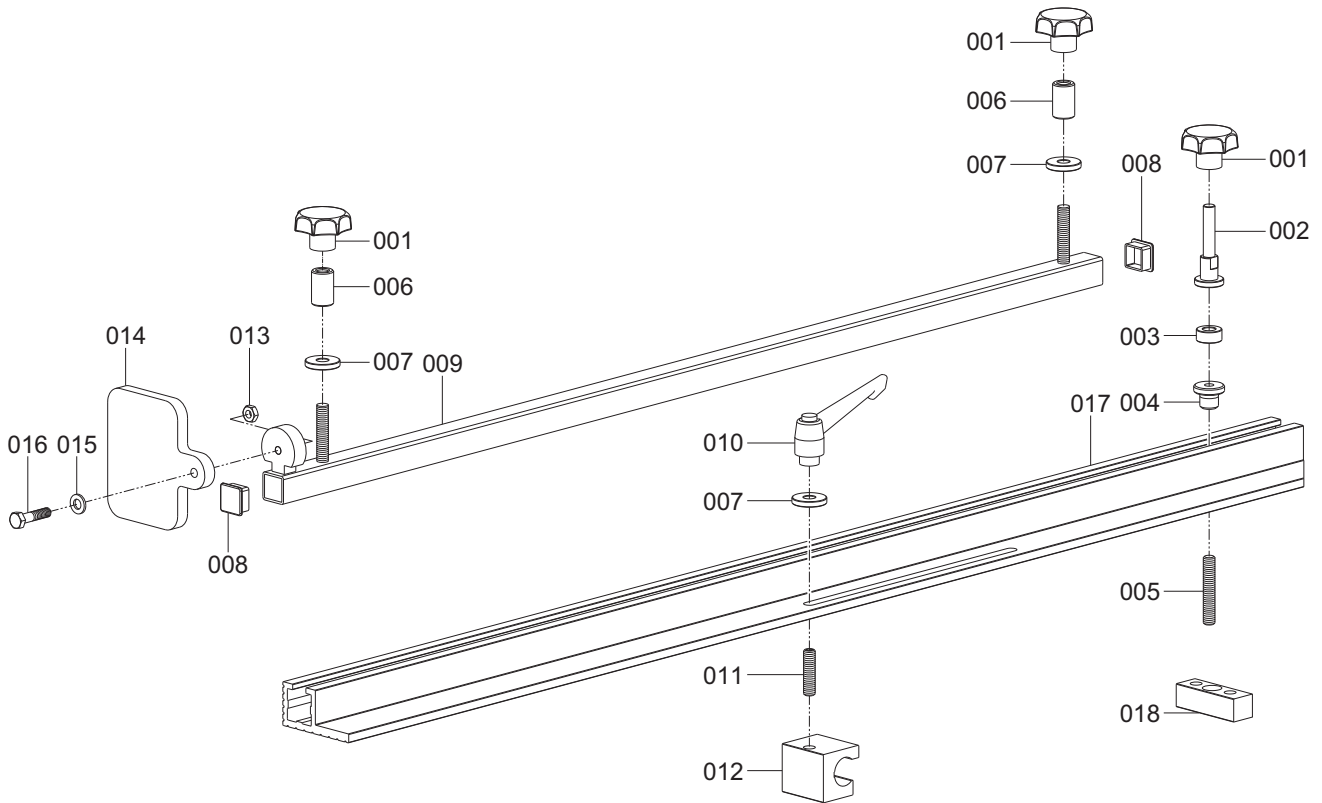

NO.	FIG. NO.	DESCRIPTION
001	402070003	Star-Shaped Knob 1083-810-M10
002	ST-L003	Setscrew
004	ST-L005	Gap Ring
003	ST-L006	Positioning Ring
005	401071075	Setscrew M10x60
006	ST-L015	Locking Bash
007	RH-2040	Washer
008	402130008	Square Insert
009	ST-L013	Displacement Pipe
010	402040001	Adjust Handle DA7012-A10
011	401071071	Setscrew M10x40
012	ST-L031	C-Fastening Block
013	401103001	Lock Nut M8
014	ST-L014	Damper
015	401140004	Washer $\phi 8$
016	401010022	Hex Head Bolt M8x35
017	ST-L001B	45° Fence

6-6 SAFETY GUARD UNIT

SIMPLE TYPE SAW GUARD

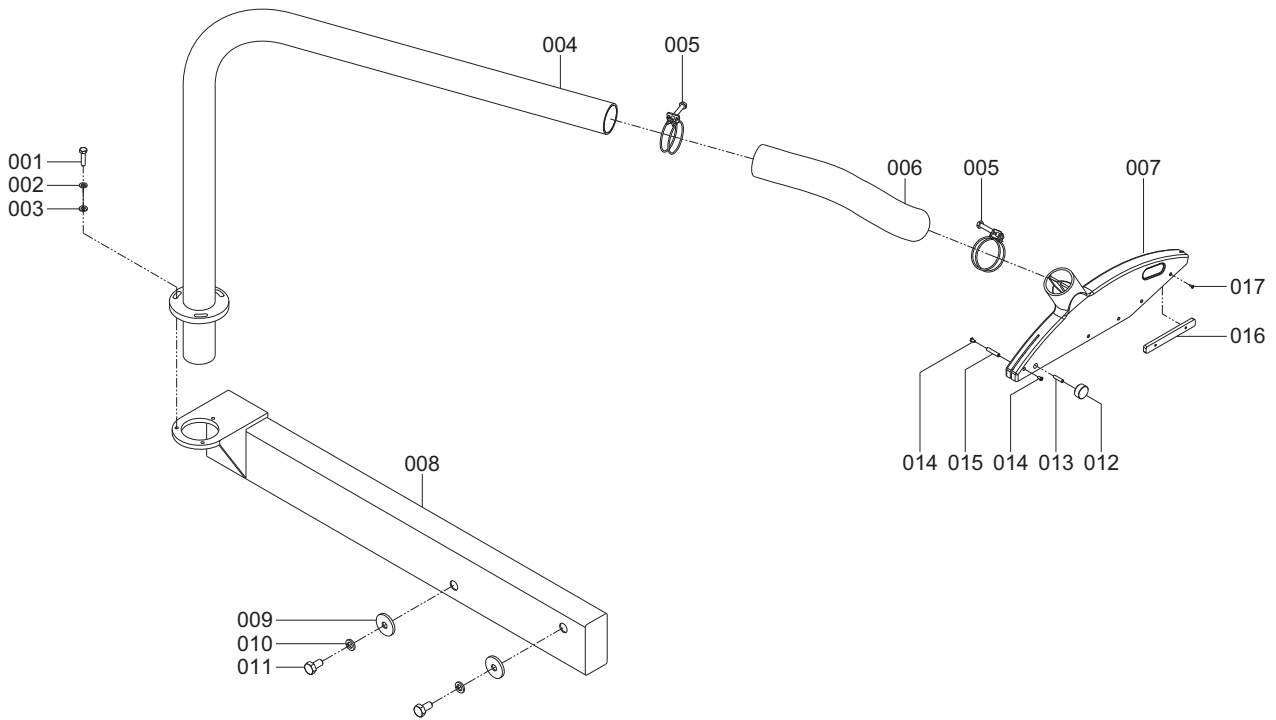

NO.	FIG. NO.	DESCRIPTION	NO.	FIG. NO.	DESCRIPTION
001	401010010	Hex Head Bolt M6x25	009	LST-H003	Washer
002	401150003	Lock Washer $\phi 6$	010	401150008	Lock Washer $\phi 16$
003	401140010	Washer $\phi 6$	011	401010069	Hex Head Bolt M16x70
004	LST-H002	Join Base	012	LST-C035	Shaped Knob
005	410090002	Tube Clip $\phi 63$	013	401072057	Setscrew M8x35
006	410050015	Elastic Tube $\phi 60$	014	401042012	Phillips Head Screw M4x8
007	LST-C032A	Safety Guard	015	LST-C038	Pin
008	LST-H001	Fixed Base 1m	016	LST-C036	Safe Sheet
	LST-H001A	Fixed Base 1.3m	017	401060004	Wooden Screw 1/8"x3/8"L
	LST-H001B	Fixed Base 1.5m			

DUST-COLLECTING FASTENING RACK

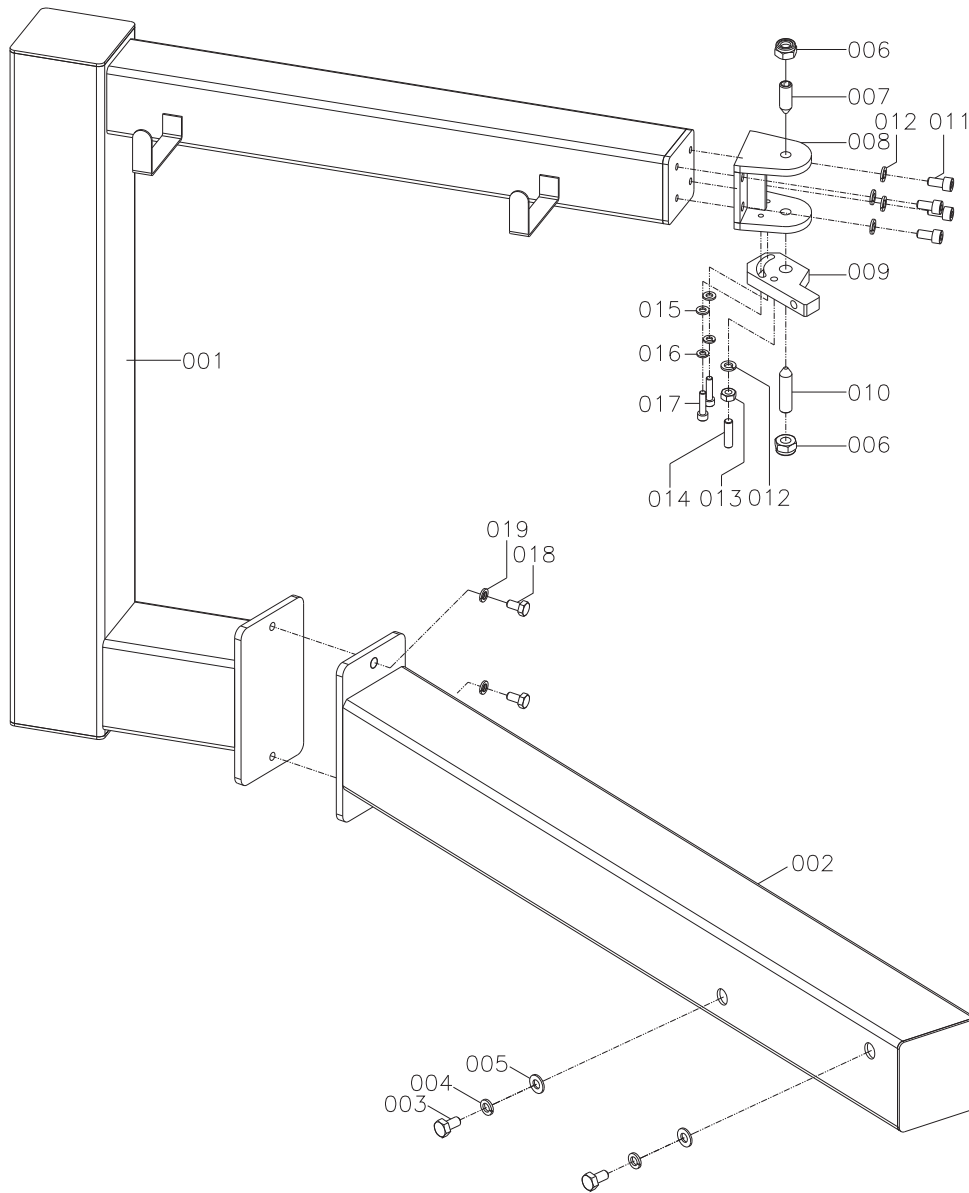

NO.	FIG. NO.	DESCRIPTION	NO.	FIG. NO.	DESCRIPTION		
001	LST-H005	Fixed Stand	008	ST-D525-0-1	Fasten Base		
	LST-H006	Fixed Stand	009	ST-D526-0-0	Adjust Block		
002	LST-H004	Fixed Base	1m	010	ST-D533-0-1	Setscrew	
	LST-H004A	Fixed Base	1.3m	011	401022076	Cap Screw	M8x16
	LST-H004B	Fixed Base	1.5m	012	401150004	Lock Washer	φ8
	LST-H007	Fixed Base	1m	013	401101005	Hex Nut	M8
	LST-H007A	Fixed Base	1.3m	014	401072055	Setscrew	M8x25
	LST-H007B	Fixed Base	1.5m	015	401140003	Washer	φ6
003	401010075	Hex Head Bolt	M16x130	016	401150003	Lock Washer	φ6
004	401150008	Lock Washer	φ16	017	401022056	Cap Screw	M6x25
005	LST-H003	Washer		018	401010036	Cap Screw	M10x25
006	401103003	Lock Nut	M12	019	401150005	Lock Washer	φ10
007	ST-I023	Setscrew					

SAFETY GUARD CONNECTING ARM

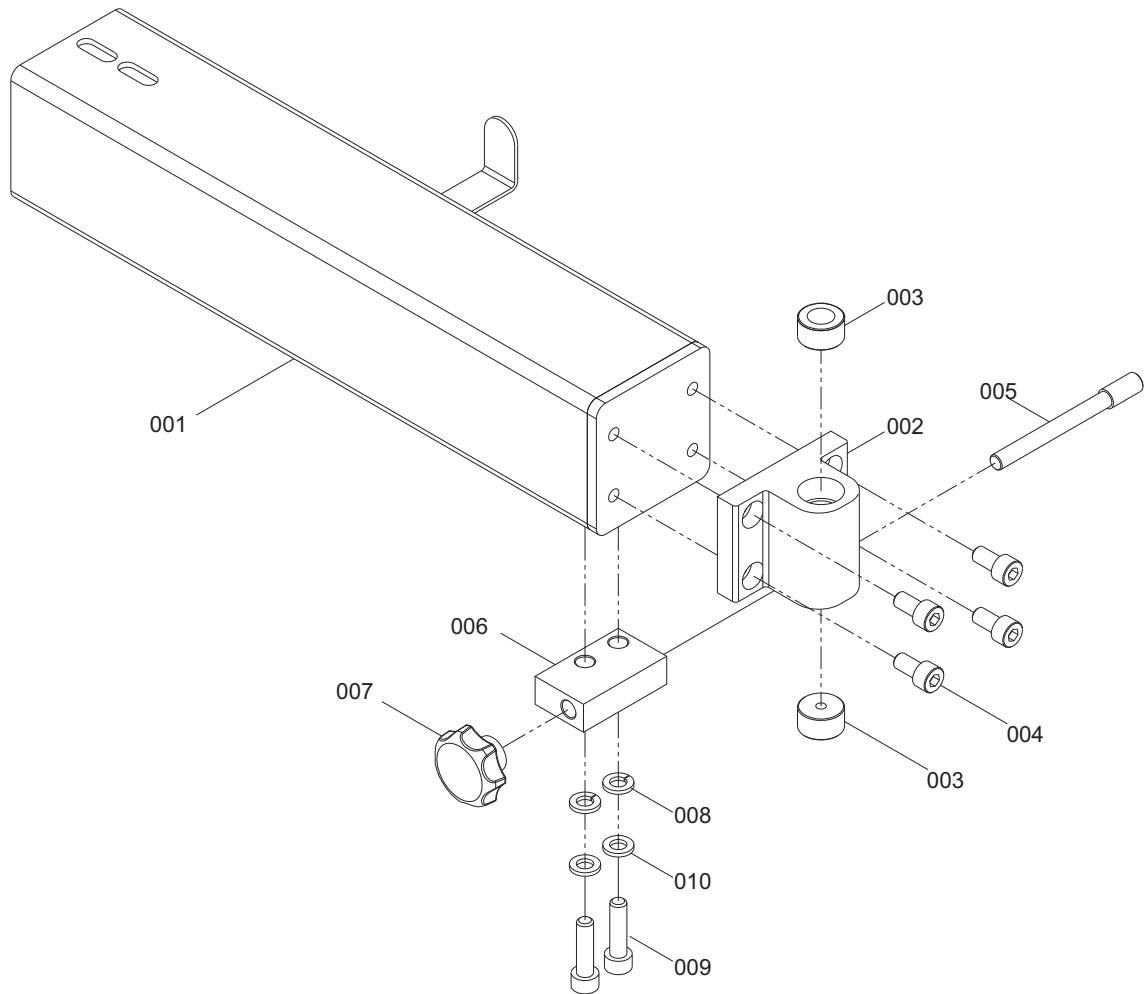

NO.	FIG. NO.	DESCRIPTION	
001	ST-D532-0-0	Rotary Arm	1m
	ST-D532-1-1	Rotary Arm	1.3m
	ST-D532-2-0	Rotary Arm	1.5m
002	ST-D027B	Connect Block	
003	ST-D527-0-0	Bush	
004	401022076	Cap Screw	M8x16
005	ST-D531-0-0	Lock Shaft	
006	ST-D529-0-1	Fixed Block	
007	402070002	Knob	7083.710-M8
008	401150004	Lock Washer	φ8
009	401022080	Cap Screw	M8x30
010	401140004	Washer	φ8

LUX SAW GUARD

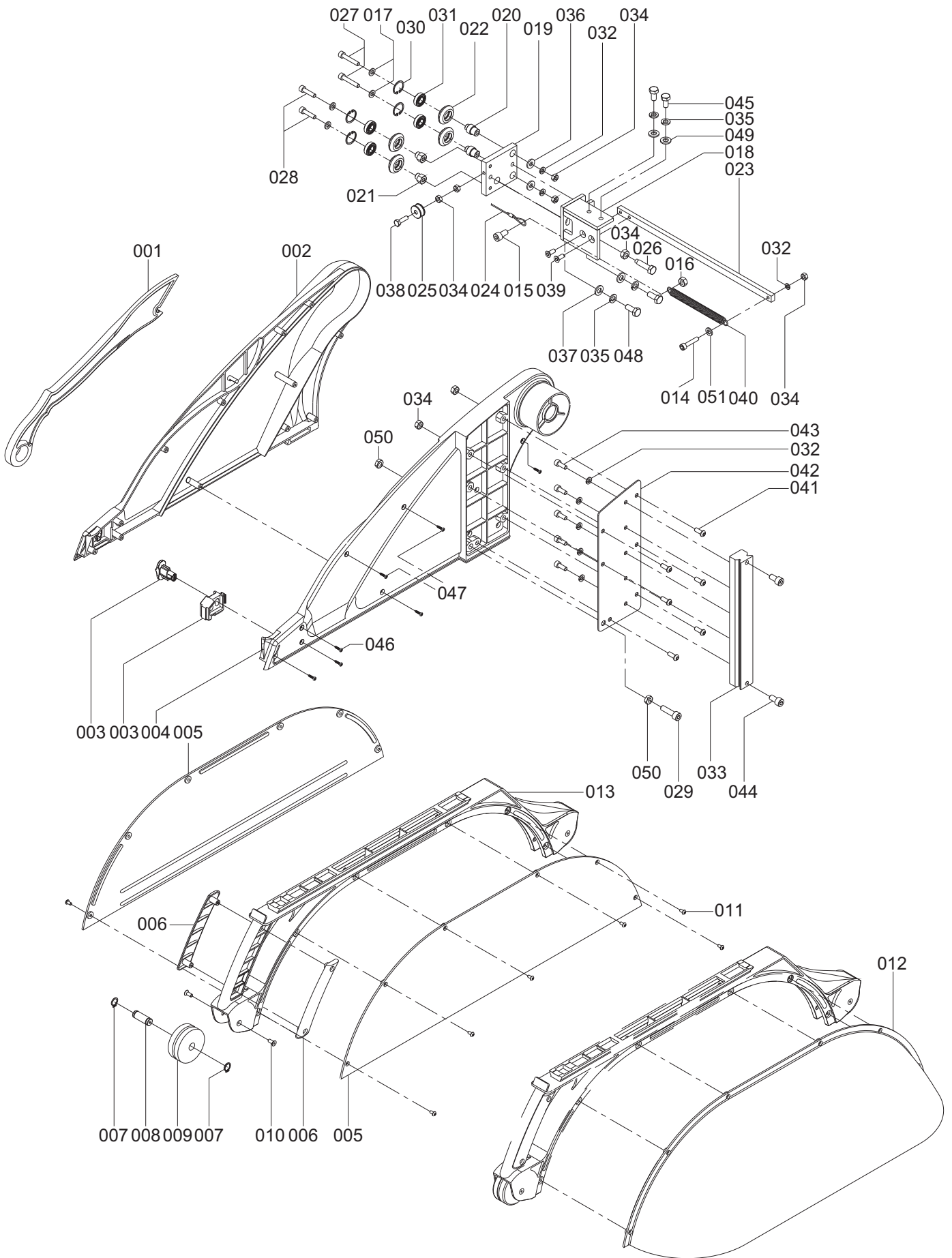

NO.	FIG. NO.	DESCRIPTION	NO.	FIG. NO.	DESCRIPTION
001	ST-Q047B	Push Stick	045	401010019	Hex Head Bolt M8x20
002	ST-D311A	Left Safety Guard	046	401060001	Phillips Head Screw 1/8"x3/4"L
003	ST-D314	Open/Lock Button	047	401060003	Phillips Head Screw 1/8"x5/8"L
004	ST-D311B	Right Safety Guard	048	401010018	Hex Head Bolt M8x16
005	ST-D303A	Chip Guard Cover	049	401140016	Washer $\phi 8 \times \phi 23 \times 3t$
006	ST-D313	Grip Cover	050	401103005	Hex Nut M8
007	401252007	Retain Ring $\phi 12$	051	401140010	Washer $\phi 6 \times \phi 13$
008	ST-D032A	Pin			
009	ST-D033A	Slide Wheel			
010	401052118	Countersink Head Screw M5x12			
011	401032008	Button Head Screw M4x8			
012	ST-D304A	Chip Guard Cover			
013	ST-D312	Grip Cover Base			
014	401022057	Cap Screw M6x30			
015	401022051	Cap Screw M6x12			
016	401103005	Lock Nut M6			
017	ST-D522-0-0	Washer			
018	ST-D512-0-1	Fixed Base			
019	ST-D513-0-1	Fixed Block			
020	ST-D514-0-1	Fixed Shaft			
021	ST-D515-0-1	Adjust Shaft			
022	ST-D516-0-1	Slide Wheel			
023	ST-D519-0-1	Spring Fixed Bar			
024	ST-D521-0-0	Wire Rope			
025	ST-D524-0-0	Slide Wheel			
026	ST-D520-0-1	Setscrwe			
027	401022058	Cap Screw M6x35			
028	401022056	Cap Screw M6x25			
029	401022082	Cap Screw M8x40			
030	401251017	Retain Ring $\phi 22$			
031	403013232	Ball Bearing 6900			
032	401150003	Lock Washer $\phi 6$			
033	ST-D518-1-0	Slide Wheel			
034	401101004	Hex Nut M6			
035	401150004	Lock Washer $\phi 8$			
036	401140003	Washer $\phi 6 \times \phi 16$			
037	401140016	Washer $\phi 8 \times \phi 23$			
038	401032035	Button Head Screw M6x30			
039	401052129	Countersink Head Screw M6x12			
040	ST-D038A	Spring			
041	401032033	Button Head Screw M6x20			
042	ST-D315	Join Block			
043	401022015	Cap Screw M6x12			
044	401022076	Cap Screw M8x16			

6-7 OPTION ACCESSORIES UNIT

RAPID CLAMP BASE

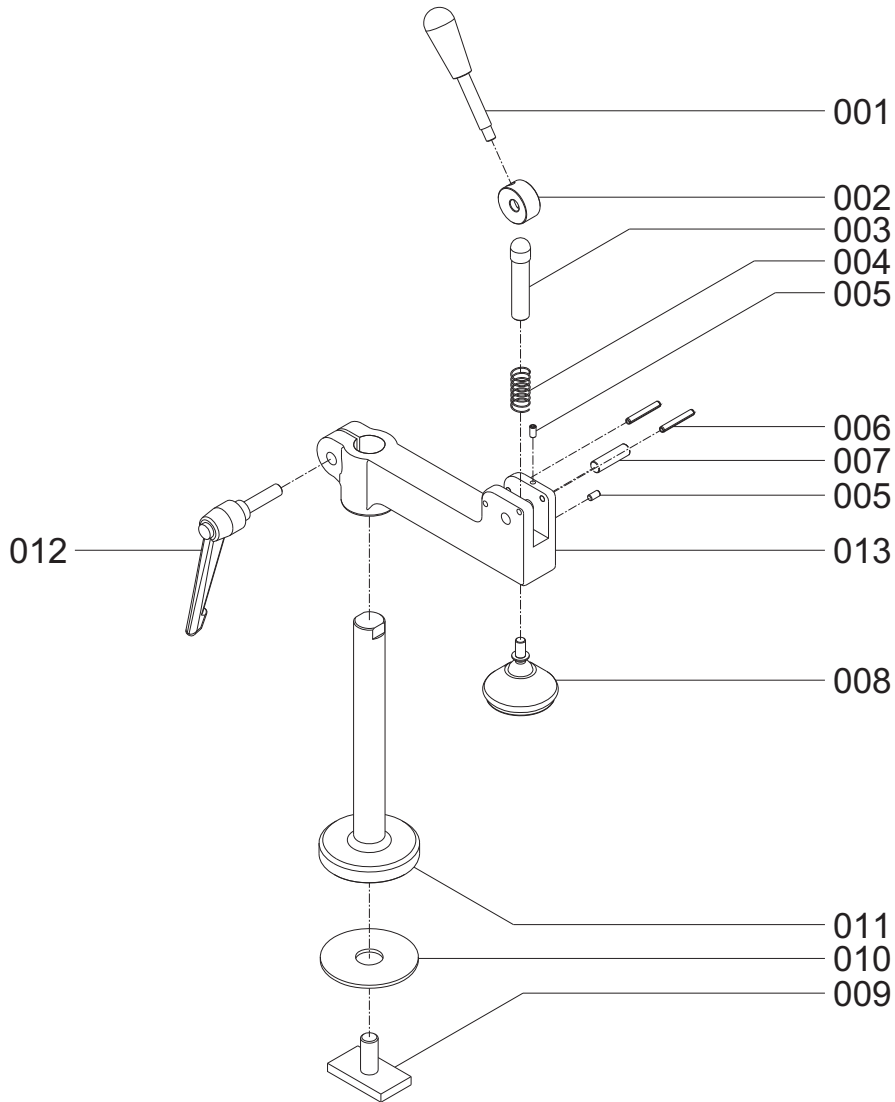

NO.	FIG. NO.	DESCRIPTION	
001	402010006	Ellipse Knob	1162-M8-100
002	ST-L026	Eccentric Wheel	
003	ST-L025	Carry Cylinder	
004	ST-L028	Spring	
005	401072025	Setscrew	M5x10
006	401200003	Spring Pin	φ5x35
007	ST-L027	Spindle	
008	401260002	Adjust Clides	
009	ST-L023	T-Block	
010	ST-L021	Washer	
011	ST-L020	Fixed Mounting	
012	402040003	Adjust Handle	65A-M1040
013	ST-L022A	Adjust Mounting	

AUXILIARY CROSSCUT CARRIAGE

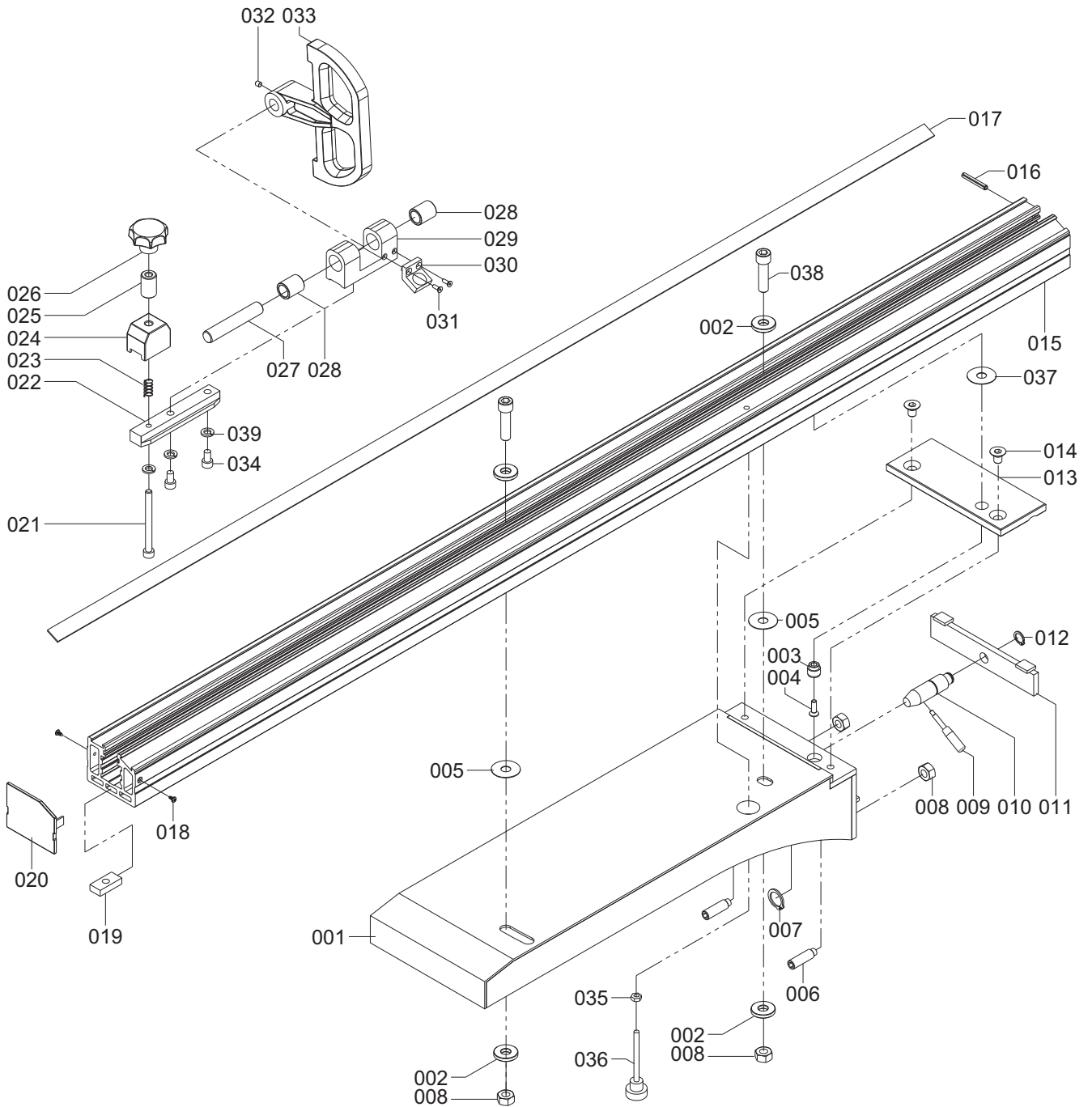

NO.	FIG. NO.	DESCRIP TION	NO.	FIG. NO.	DESCRIP TION
001	ST-N088A	Fastening Base	021	401022092	Cap Screw M8x90
002	RS-3021	Washer	022	ST-N027	Lock Base
003	ST-N004	Positioning Pin	023	ST-N022	Spring
004	401052132	Countersink Head Screw M6x20	024	ST-N013	Lock Block
005	ST-N092	Washer	025	ST-N014	Lock Bush
006	ST-N091A	Setscrew	026	402070002	Star-Shaped Knob M8
007	401252015	Retain Ring STW-20	027	ST-N011	Rotary Shaft
008	401101007	Hex Nut M12	028	ST-N010	Bush
009	402010002	Handle 7108-M10-100	029	ST-N007	Adjust Base
010	ST-N090	Adjust Shaft	030	ST-N053	Magnifier
011	ST-N089	Lock Bar	031	401052111	Countersink Head Screw M4x14
012	401252009	Retain Ring STW-14	032	401072033	Setscrew M6x6
013	ST-N087A	Fixed Board	033	ST-N008	Positioning Board
014	401052150	Countersink Head Screw M10x16	034	401022076	Cap Screw M8x16
015	ST-N058A	Fence Scale Base	035	401101004	Hex Nut M6
016	401200008	Spring Pin $\phi 6 \times 40$	036	ST-N023	Embossing Screw
017	ST-N063	Scale	037	ST-N005	Washer
018	401060004	Wooden Screw 1/8"x3/8"L	038	401022130	Cap Screw M12x45
019	ST-N059	Fixed Sheet	039	401150004	Lock Washer $\phi 8$
020	ST-N060	Cover			

PNEUMATIC CLAMP

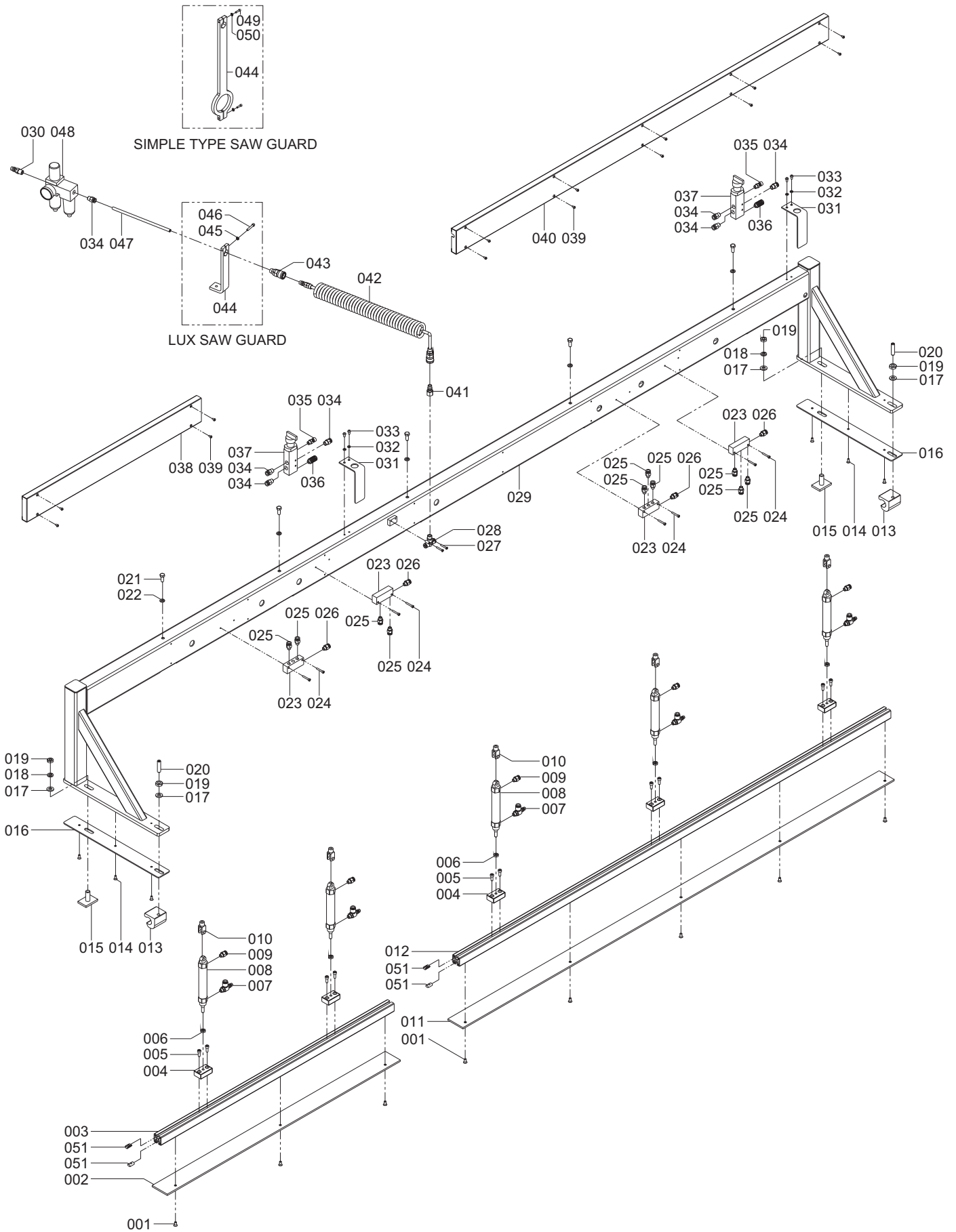

NO.	FIG. NO.	DESCRIPTION	NO.	FIG. NO.	DESCRIPTION
001	401052129	Countersink Head Screw M6x12	039	401032008	Button Head Screw M4x8
002	ST-R029	Clamp Element 2.6m	040	ST-R039	Cover 2.6m
	ST-R006	Clamp Element 3.2m		ST-R012	Cover 3.2m
003	ST-R027	Clamp Bar 2.6m	041	410010007	Quick Joint 1/4"
	ST-R004	Clamp Bar 3.2m	042	410050002	Tube 5x8
004	ST-R007	Join Block	043	410010006	Quick Joint 5x8-
005	401022053	Cap Screw M6x16	044	ST-R013	Fixed Rack LUX
006	401101005	Hex Nut M8		ST-R013A	Fixed Rack SIMPLE
007	410040005	Quick Joint 1/8"-4x6	045	401150002	Lock Washer ϕ 5
008	409010001	Cylinder ϕ 20x80	046	401022034	Cap Screw M5x30
009	410010017	Quick Joint 1/8"-4x6	047		Tube 5x8
010	ST-R008	Y-Shape Connector	048	409040001	F.R.L Connection
011	ST-R028	Clamp Element 2.6m	049	401022056	Cap Screw M6x25
	ST-R005	Clamp Element 3.2m	050	401150003	Lock Washer ϕ 6
012	ST-R026	Clamp Bar 2.6m	051	401130001	Special Nut TSN 306
	ST-R003	Clamp Bar 3.2m			
013	ST-L031A	Fixed Block			
014	401052118	Countersink Head Screw M5x12			
015	ST-L011	T-Block			
016	ST-R002	Clamp Element			
017	401140017	Washer ϕ 10			
018	401150005	Lock Washer ϕ 10			
019	401101006	Hex Nut M10			
020	401072071	Setscrew M10x40			
021	401010018	Hex Head Bolt M8x16			
022	401150004	Lock Washer ϕ 8			
023	ST-R014B	Fork Lump			
024	401042002	Pillips Head Screw M4x30			
025	410010017	Quick Joint 1/8"-4x6			
026	410010009	Quick Joint PC8-01			
027	401042002	Pillips Head Screw M4x30			
028	410010013	Therr Joint 1/4" ϕ 8			
029	ST-R001C	Clamp Base 2.6m			
	ST-R001	Clamp Base 3.2m			
030	410010014	Quick Joint 1/4"			
031	ST-R009	Fixed Rack			
032	401150002	Lock Washer ϕ 5			
033	401032016	Button Head Screw M5x8			
034	410010010	Quick Joint PC8-02			
035	409080009	Throttle Silencer 1/8"			
036	409080008	Plastic Silencer 1/8"			
037	409030001	Control Valve 5/2			
038	ST-R038	Cover 2.6m			
	ST-R011	Cover 3.2m			