



6310

6" x 108" Oscillating Edge Sander

Owner's Manual



I.SAFETY INSTRUCTION

PREFACE

We appreciate your purchase of our machine. This machine is designed and manufactured for efficient, heavy-duty operations. This manual concerns the operation, safety and maintenance of the machine. This manual should be kept readily available to the operator for reference. The operator should read this manual carefully before operation to ensure safe, smooth operation of the machine. Our warranty will not apply if there is any improper operation or maintenance of the machine.

When you receive the machine, please check the model, all accessories listed on the packing list and check if there are any parts damaged during transportation. If any part is missing or parts are found to be damaged, please immediately contact your local distributor or machine manufacturer. Again, we would like to thank you for your purchase.

WARRANTY

If any part is proved to be defective within ONE YEAR from the date of purchase then the manufacturer or distributor shall repair or replace the part provided the defective part is returned immediately to the manufacturer or distributor. The manufacturer or distributor shall have no obligation to repair or replace those parts failing due to operator carelessness, misuse or due to any cause such as parts failing due to poor lubrication, inadequate cleaning, improper operating environment, improper utilities or operator error

I.SAFETY INSTRUCTION

11. SECURE WORK.

Use clamps or a vice to hold work when practical. It is safer than using your hand and frees both hands to operate the machine.

12. DO NOT OVERREACH.

Keep proper footing and balance at all times.

13. MAINTAIN MACHINE IN TOP CONDITION.

Keep machine clean for best and safest performance. Follow instructions for lubricating and changing accessories.

14. DISCONNECT MACHINE FROM POWER SOURCE.

Before servicing and when changing accessories, or when mounting and remounting motor.

15. USE RECOMMENDED ACCESSORIES.

Consult the owner's manual for recommended accessories.

16. NEVER LEAVE MACHINE RUNNING UNATTENDED. TURN POWER OFF.

17. Protective guards and shields must be in place at all times unless that specific part requires servicing.

18. Never clean or remove chips while the machine is running.

19. Do not remove or alter warning labels and replace any that become obscured.

1.1.2. ADDITIONAL SAFETY RULES FOR OSCILLATING BELT EDGE SANDER

1. Never stand directly in line of workpiece sanding; as throw out is a possibility always stands to one side of your machine.
2. Keep guards in place when the sanding belt surface is not use.
3. Do not perform sanding operations until the dust collection system is started.
4. Do not place hands above the sanding unit.
5. Properly ground the machine.
6. Do not open the guards while the machine is running.

3. INSTALLATION

1.1. SAFETY REGULATIONS

2.1.1. GENERAL SAFETY RULES



WARNING

Do not attempt to operate until you have read thoroughly and understand completely all instructions, rules, etc. contained in this manual. Failure to comply can result in accidents involving fire, electric shock, or serious personal injury. Keep owners manual and review frequently for continuous safe operation.

1. KNOW YOUR MACHINE.

For your own safety, read the owner's manual carefully. Learn its application and limitations as well as specific potential hazards pertinent to this machine.

2. KEEP GUARDS IN PLACE AND IN WORKING ORDER.

3. REMOVE ADJUSTING KEYS AND WRENCHES.

For habit of checking to see that keys and adjusting wrenches are remove from the machine before turning it on.

4. KEEP WORK AREA CLEAN.

Cluttered areas and benches invite accidents.

5. DO NOT USE IN DANGEROUS ENVIRONMENTS.

Do not use power tools in damp or we locations, or expose them to rain. Keeps work area well illuminated.

6. KEEP CHILDREN AWAY.

All visitors should be kept at a safe distance from work area.

7. MAKE WORKSHOP CHILDPROOF.

With padlocks, master switches, or by removing starter keys.

8. DO NOT FORCE THE MACHINE.

It will do the job better and be safer at the rate for which it was designed.

9. USE THE RIGHT TOOLS.

Do not force the machine or attachments to do a job for which they were not designed.

10. WEAR PROPER APPAREL.

Avoid loose clothing, gloves, neckties, rings, bracelets, or jewelry, which could be caught in moving parts. Nonslip footwear is recommended. Wear protective hair covering to contain long hair.

11. SECURE WORK.

Use clamps or a vice to hold work when practical. It is safer than using your hand and frees both hands to operate the machine.

12. DO NOT OVERREACH.

3. INSTALLATION

1.2. SPECIFICATIONS

MODEL	15-210M1
Working capacity	300(W) x920mm (L)
Sanding belt size	6"(W) x108"mm (L)
Belt linear speed	(50HZ) 910 m/min (60HZ) 1080 m/min
Belt drive motor	
Oscillating drive motor	-
Caliber of dust collector	4"(Ø100) x1
Machine dimensions (L x W x H)	160x67x100 mm
Net weight	205kg

All specifications, dimensions and design characteristics shown in this manual are subject to change without notice.

1.3. FUNCTION OF THE MACHINE

This oscillating belt edge sander is designed and manufactured for long-term operation, creating superior sanding surface results for wood products. New design of oscillation belt system- combination of main motor with gear device. Allow for sanding on edges, plane surfaces, rims and curved surfaces, providing the right function for specific jobs.

The machine consists of the machine frame, the sanding unit, the working table and the corner table. The sanding unit extremely easy to replace and adjust sanding belt, The working table for versatile vertical oscillating edge sanding and the corner table for curved corner sanding. All tables equipped with tilting and adjustable height devices. So it is variable to meet various types of workpiece requirement.

WARNING

This machine is suited for sanding wood products only. Do not use this machine for sanding metal products.

3.1. SELECTION OF LOCATION

Requirement of operating environment the operating temperature for this machine should be between +5°C and +40°C ,while the relative humidity should not exceed 50% at a maximum temperature of +40°C.

3.2. LIFTING THE MACHINE

1. The machine should be lifted with steel cable or a hydraulic hand pallet truck. There are two lifting rings located at the front and rear of the machine.
2. Make sure the steel cable used is strong enough that it won't break during lifting.
3. Their forks should insert through the machine bottom.
4. Attention should be paid to the balance of the machine while lifting.
5. The weight of the machine is listed below.

Machine weight	Forklift or hydraulic hand pallet truck capacity
205Kg	255Kg

- ☞ When lowering the machine to the floor, it must be done slowly and carefully. Do not let the machine jolt against the floor. And replace the lifting rings (A) with star knobs (B).

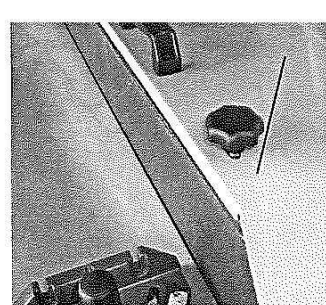
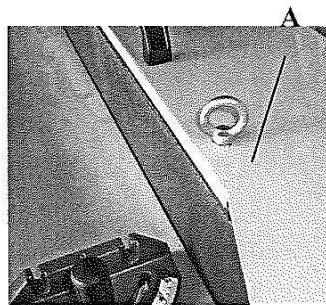

3.3. INSTALLATION AND LEVELLING

Install this machine on a solid and level concrete floor. Leave proper space around the machine for handling the materials to be machined. Four rubber pads are furnished with the machine, which are to be placed under the machine at the Four Corners.

After the machine has been located at a proper work site, proper leveling needs to be made. The following steps should be taken:

3. INSTALLATION

3.1. INSTALLATION AND LEVELLING

Install this machine on a solid and level concrete floor. Leave proper space around the machine for handling the materials to be machined. Four rubber pads are furnished with the machine, which are to be placed under the machine at the Four Corners.

After the machine has been located at a proper work site, proper leveling needs to be made. The following steps should be taken:

1. Screw the rubber pads (A) under the machine.
2. Adjust the leveling screws until proper leveling is obtained.

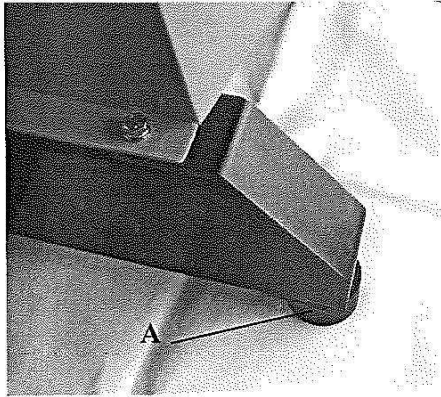

3.2. POWER SUPPLY REQUIREMENT

Insufficient voltage from factory power source may affect the power output of the motor.

It is important to connect this machine to the correct voltage in the factory power source. Use only an independent power source.

3.6. CONNECT POWER SOURCE WIRES

1. Before connecting the power wires make sure the voltage between the machine and your factory power source is the same.
2. Connect the power wires to the breaker.
3. The machine must be properly grounded to prevent possible injury from electrical shock.
4. **Qualified electrical personnel should perform all electrical connections.**

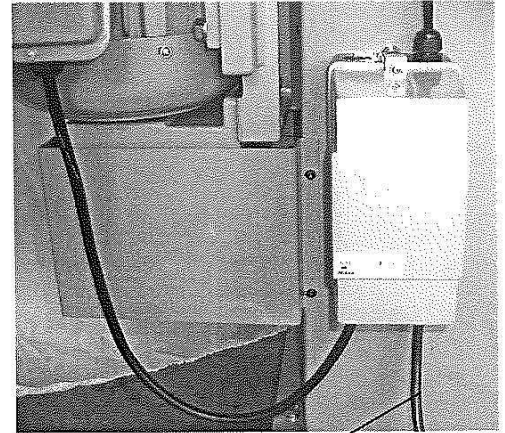

Connect to the Breaker

WARNING

Grounding should be based on the local regulations.

3.7. CHECK POWER WIRES CONNECTION

After the power wires have been connected it is necessary to check if the power wires are connected to the correct connection points.

Press the sanding belt drive motor start switch (A) then the sanding belt should rotate according to the indicant (B) direction. If not, any two of the three power wires "R.S.T." need to be changed.

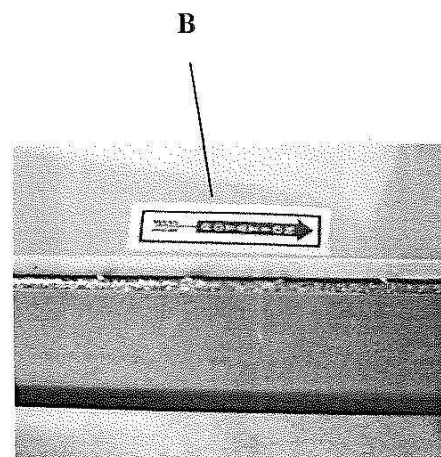

3.8. CONNECT DUST COLLECTION SYSTEM

4.2. REPLACE THE SANDING BELTS

1. Disconnect the machine from power source.
2. Open the guard on the sanding unit.
3. Shift the sanding belt lever (A) to release the sanding belt tension according to the indicant direction.
4. Take out the old sanding belt.
5. Replace the new sanding belt.
6. Shift the sanding belt lever (A) to tighten the sanding belt tension according to the indicant direction.
7. Make the sanding belt adjustment. (See instructions show on adjust the sanding belt procedures. 4.3)
8. Close the guards.

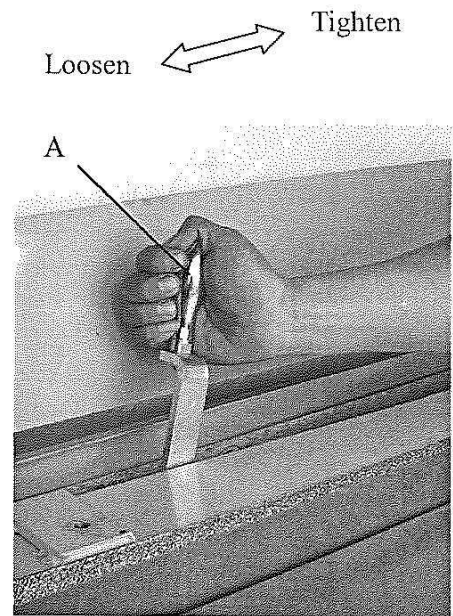

1.3. ADJUST THE SANDING BELT

After the sanding belt has been replaced it is the necessary to check the sanding belt the middle of the drive roller. If not, must the sanding belt adjustment.

1. Loosen the fix nut (A).
2. Turn the adjustment knob (B) counter-clockwise then the sanding belt should move upward.
3. Turn the adjustment knob (B) clockwise then the sanding belt should move downward.
4. After adjustment tighten fix nut (A).

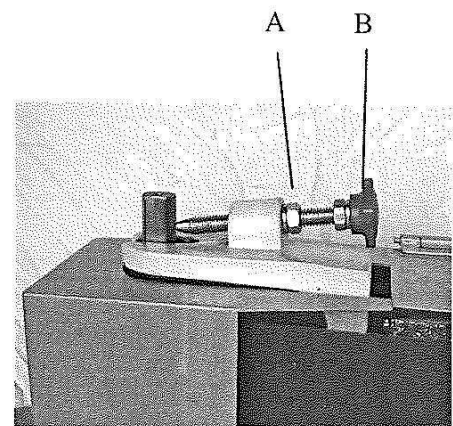

4.4 WORKING TABLE POSITION ADJUSTMENT

The table can be adjusted position according to different workpiece thickness and sanding belt sharp conditions.

Because the table is designed a special balance mount, so we can be easily adjusted simply be hand to push or pull.

Adjusted as follows:

1. Loosen the adjustable hand lever (A).
2. Move the table (B) into the desired position by hand.
3. Tighten the adjustable hand lever (A). After the table position is desired.

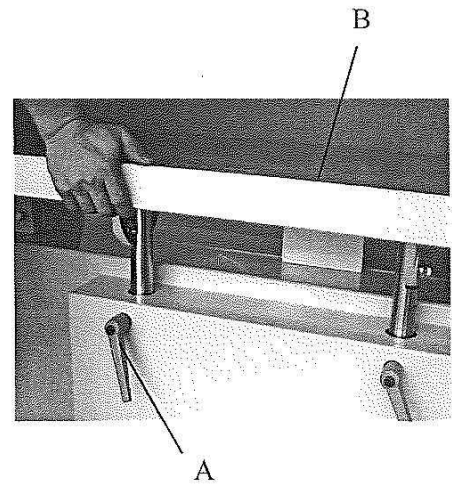

1.1. WORKING TABLE TILTING TO SLANT ANGLE ADJUSTMENT

The working table angle can be adjusted tilting angle according to different workpiece angle adjust as follows:

1. Put the workpiece on the working table.
2. Loosen the hand levers (A) on the both sides.
3. Swivel the table into the desired position with the workpiece or by reading the indicator scale (B).
4. Tighten the hand levers (A). After the table slant angle is desired.
5. The working table can be adjusted clearance with sanding belt. If it is required, loosen the fix screw (C) then move the working table to desire position. After adjustment, re-tighten the fix screw.

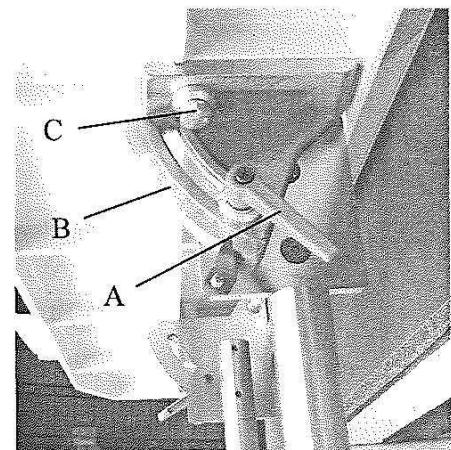

4. OPERATION

1.4. ADJUST THE MITER GAUGE ON THE WORKING TABLE

The table can be adjusted the miter gauge (A) angle according to different workpiece tilting angle.

The miter gauge with easy-to-read graduation is precisely set on the working table for the convenience of sanding.

Adjusted as follows:

1. Loosen the lock handle (B).
2. Rotate the miter gauge into the desired position by reading the indicator scale (C).
3. Tighten the lock handle (B). After the miter gauge position is desired.

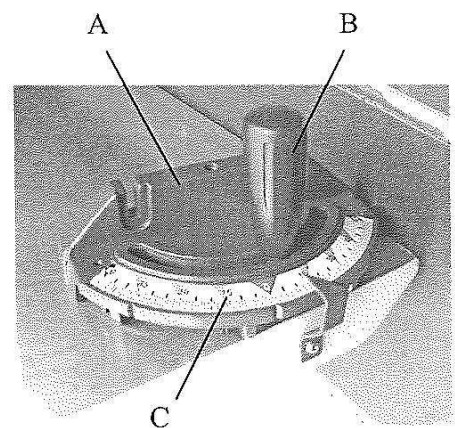

1.1. CURVED SANDING

This machine provided with corner sanding table for curved sanding. When use this function must be rotate the rear dust hood (A) to convenience position by loosen the hand lever (B).

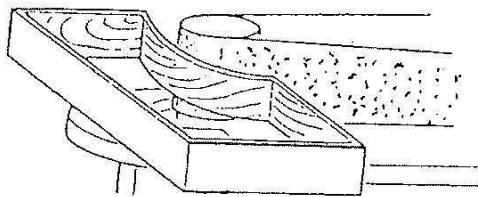

Curved sanding

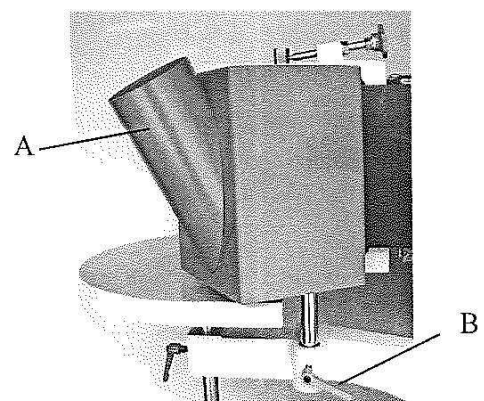

4. OPERATION

1.2. CORNER TABLE POSITION ADJUSTMENT

The corner table can be adjusted position according to different workpiece thickness and sanding belt sharp conditions.

Adjusted as follows:

1. Loosen the adjustable hand lever (A).
2. Move the table (B) into the desired position by hand.
3. Tighten the adjustable hand lever (A). After the table position is desired.

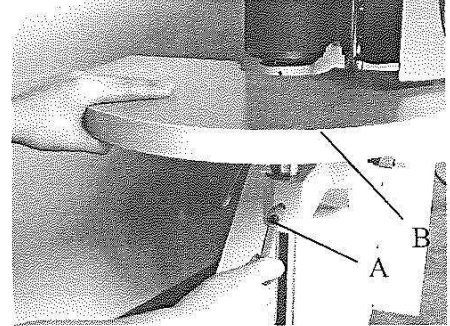

1.3. CORNER TABLE TILTING TO SLANT ANGLE ADJUSTMENT

The corner table angle can be adjusted tilting angle according to different workpiece angle adjust as follows:

1. Put the workpiece on the working table.
2. Loosen the fix bolt (A).
3. Swivel the table into the desired position with the workpiece.
4. Tighten the fix blot (A). After the table slant angle is desired.

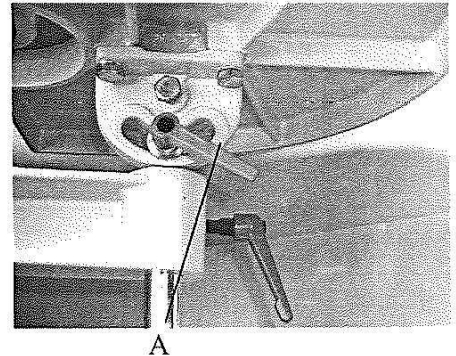

This machine is designed and manufactured for easy operation and maintenance. The proper amount of good quality grease is packed in all ball bearings, so not necessary lubrication.

The auxiliary wheel and the drive wheel are made by rubber material, after the machine has been operated for long period of time the auxiliary wheel and drive wheel may be wear. If this happens the auxiliary wheel and drive wheel needs to be replaced. When the auxiliary wheel is wear, we recommend replace all auxiliary wheel units.

4. OPERATION

5.1. PERIODIC MAINTENANCE

1. The machine requires thorough cleaning once a day.
2. Check of the auxiliary wheel and drive wheel.
3. Check of screws and bolts.

5.2. RECOMMENDED SPARE PARTS

- 1 Auxiliary wheel unit.
- 2 Drive wheel.

PARTLIST

BASE AND BELT PARTS

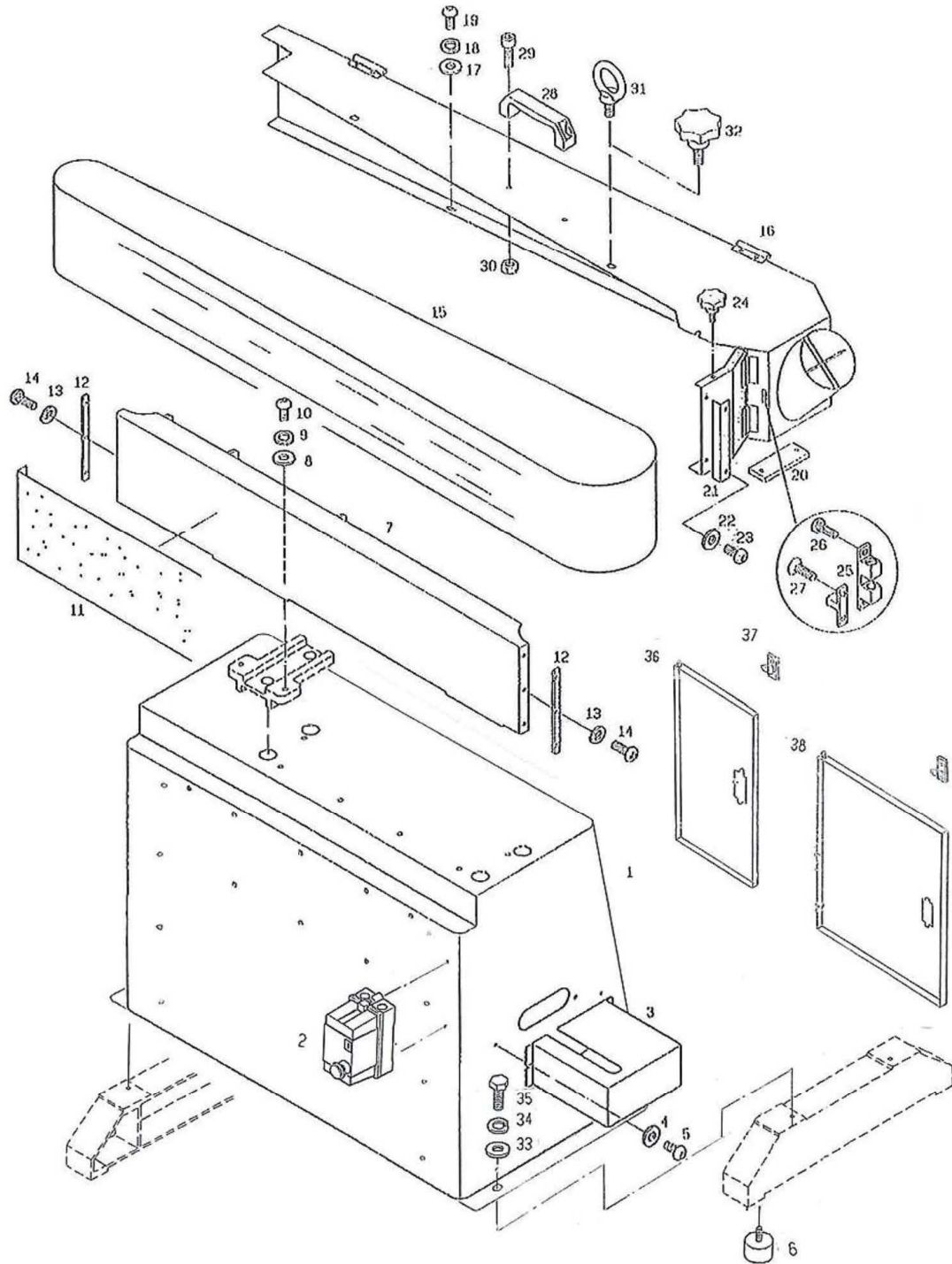

Base and Belt Parts List

Item	Description	Qty.
1	Machine base	1
2	Motor Starter	1
3	Cover	1
4	Washer	2
5	Screw	2
6	Rubber pad	4
7	Support base	1
8	Washer	4
9	Spring washer	4
10	Screw	4
11	Pad	1
12	Plate	2
13	Spring washer	6
14	Screw	6
15	Sanding belt	1
16	Dust hood	1
17	Washer	3
18	Spring washer	3
19	Screw	3

Item	Description	Qty.
20	Fixing plate	1
21	Guard plate	1
22	Washer	2
23	Screw	2
24	Hand Knob	1
25	Locker	1
26	Screw	2
27	Screw	2
28	"U" handle	1
29	Screw	2
30	Nut	2
31	Eyebolts	2
32	Hand Knobs	2
33	Washer	4
34	Spring Washer	4
35	Hex Head Bolt	4
36	Right Access Door	1
37	Door Lock	2
38	Left Access Door	1

TABLE AND COVER PARTS

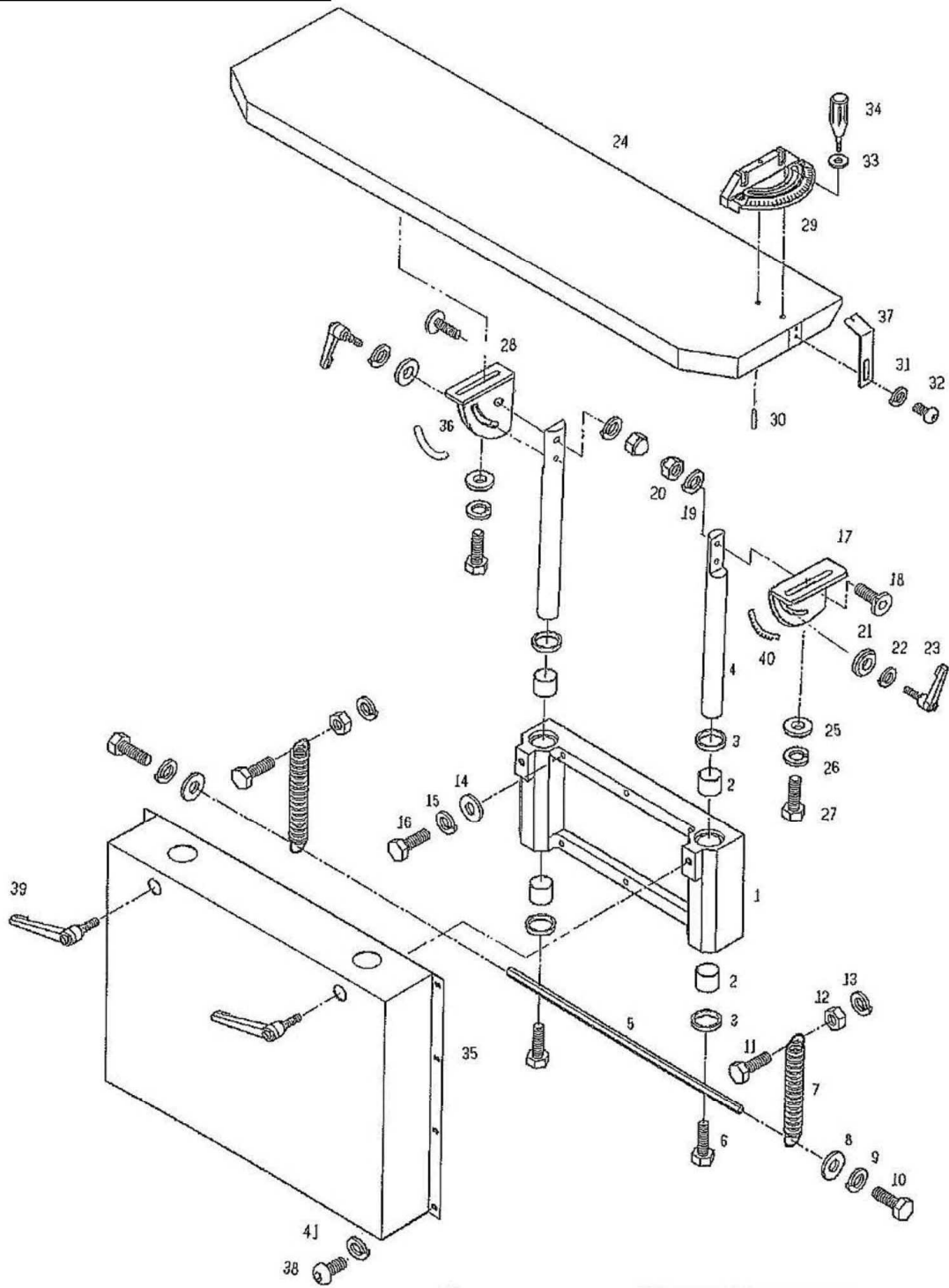
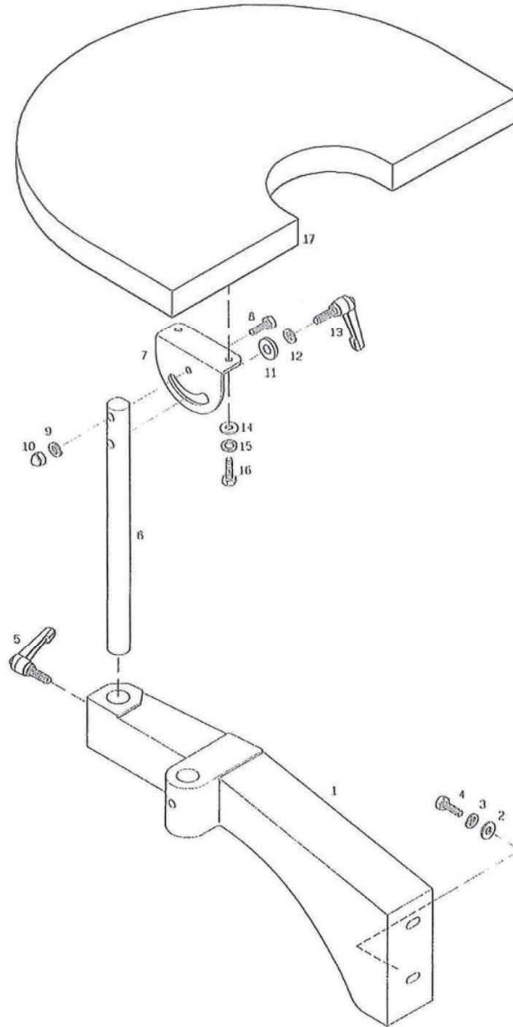

Table and Cover Parts List

Item	Description	Qty.
1	Elevation block	1
2	DU bushing	4
3	Seal	4
4	Shaft	2
5	Link	1
6	Screw	2
7	Spring	2
8	Washer	2
9	Spring washer	2
10	Screw	2
11	Screw	2
12	Nut	2
13	Spring washer	2
14	Washer	4
15	Spring washer	4
16	Screw	4
17	Adjustment base (R)	1
18	Screw	2
19	Spring washer	2
20	Nut	2

Item	Description	Qty.
21	Washer	2
22	Spring washer	2
23	Adjustable hand lever	2
24	Outside table	1
25	Washer	2
26	Spring washer	2
27	Screw	2
28	Adjustment base (L)	1
29	Miter gauge	1
30	Screw	1
31	Spring washer	1
32	Nut	1
33	Washer	1
34	Knob	1
35	Cover	1
36	Left Angle Sticker	1
37	Angle Indicator	1
38	Screw	8
39	Adjustable hand lever	2
40	Right Angle Sticker	1
41	Spring Washer	1

CORNER TABLE PARTS



Corner Table Parts List

Item	Description	Qty.
1	Support Base	1
2	Washer	2
3	Spring washer	2
4	Screw	2
5	Adjustable hand lever	1
6	Shaft	1
7	Adjustment base	1
8	Screw	1
9	Spring washer	1

Item	Description	Qty.
10	Nut	1
11	Washer	1
12	Spring washer	1
13	Adjustable hand lever	1
14	Washer	2
15	Spring washer	2
16	Screw	2
17	Corner sanding table	1

OSCILLATING UNIT PARTS

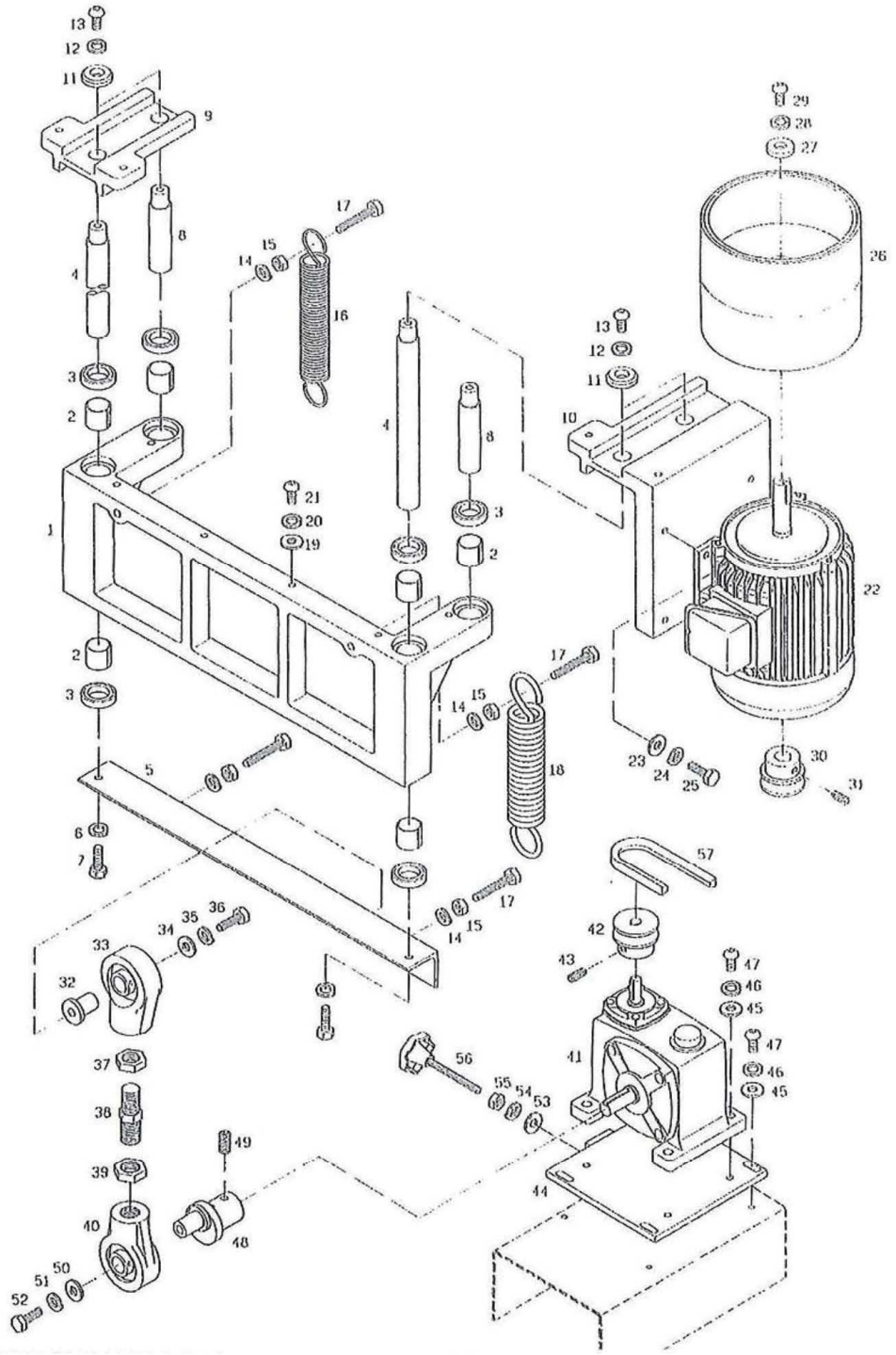

Oscillating Unit Parts List

Item	Description	Qty.
1	Elevation block	1
2	DU bushing	4
3	Seal	4
4	Shaft	2
5	Link	1
6	Spring washer	2
7	Screw	2
8	Shaft	2
9	Bracket	1
10	Bracket & Motor base	1
11	Washer	4
12	Spring washer	4
13	Screw	4
14	Spring washer	4
15	Nut	4
16	Spring	1
17	Screw	4
18	Spring	1
19	Washer	6
20	Spring washer	6
21	Screw	6
22	Motor	1
23	Washer	4
24	Spring washer	4
25	Screw	4
26	Drive wheel	1
27	Washer	1
28	Spring washer	1
29	Screw	1

Item	Description	Qty.
30	Belt wheel	1
31	Set screw	1
32	Bush	1
33	Spherical bearing	1
34	Washer	1
35	Spring washer	1
36	Screw	1
37	Lock nut	1
38	Adjustment screw	1
39	Lock Nut	1
40	Spherical bearing	1
41	Worm reducer	1
42	Belt wheel	1
43	2	2
44	Adjustment plate	1
45	Washer	8
46	Spring washer	8
47	Screw	8
48	Cam	1
49	Set screw	1
50	Washer	1
51	Spring washer	1
52	Screw	1
53	Washer	1
54	Spring washer	1
55	Nut	1
56	Knob	1
57	Belt	1

IDLER DRIVE PARTS

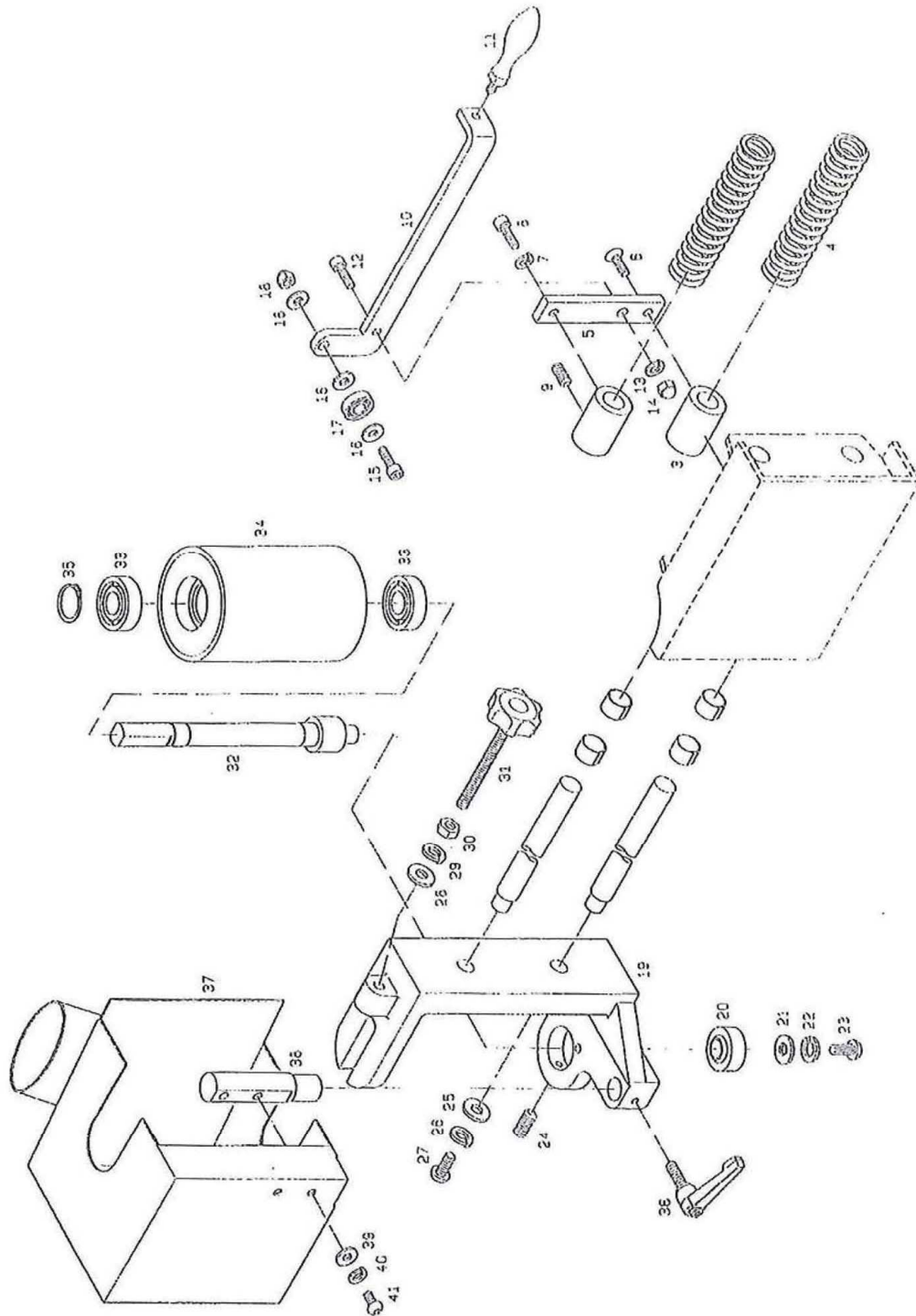

Idler Drive Parts

Item	Description	Qty.
1	Shaft	2
2	DU Bearing	4
3	Stopper Block	2
4	Spring	2
5	Plate	1
6	Screw	1
7	Spring Washer	1
8	Screw	1
9	Set Screw	4
10	Lever	1
11	Hand Knob	1
12	Screw	1
13	Spring Washer	1
14	Nut	1
15	Screw	1
16	Washer	3
17	Bearing	1
18	Nut	1
19	Bracket	1
20	Spherical Bearing	1
21	Washer	1

Item	Description	Qty.
22	Spring Washer	1
23	Screw	1
24	Washer	2
25	Spring Washer	2
26	Screw	2
27	Spring Washer	2
28	Nut	2
29	Screw	1
30	Washer	1
31	Knob	1
32	Shaft	1
33	Bearing 6204	2
34	Roller	1
35	Retaining Ring	1
36	Adjustable Hand Lever	1
37	Dust Hood	1
38	Shaft	1
39	Washer	2
40	Spring washer	2
41	Screw	2

WIRING DIAGRAM

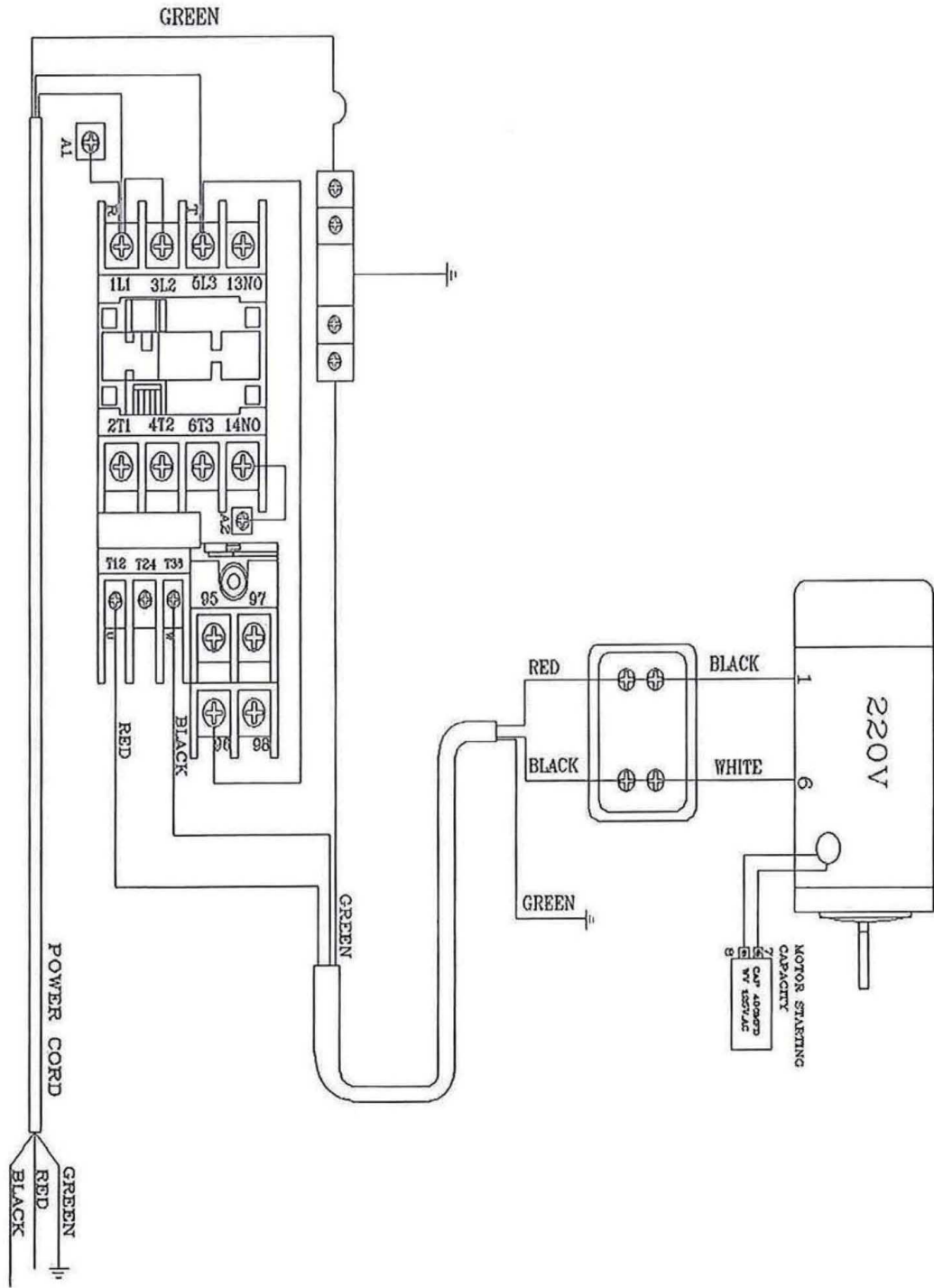

NOTES