

Sander

# Model 6305

Owner's Manual

For Models Manufactured Since 05/2015



Oliver Machinery  
1-800-559-5065  
921 Thomas Ave SW,  
Renton, WA 98057

info@olivermachinery.net  
WWW.OLIVERMACHINERY.NET

Stock Number: 6305.001  
Manual Version: 2.0.0





**READ AND UNDERSTAND ALL INSTRUCTIONS IN THIS MANUAL BEFORE ATTEMPTING TO ASSEMBLE OR OPERATE THE MACHINE.**

**FOLLOW THE INSTRUCTIONS AND THINK SAFETY!**

**THE OWNER OF THIS MACHINE IS SOLELY RESPONSIBLE FOR THE SAFETY OF ANYONE USING THIS MACHINE. SUCH RESPONSIBILITY INCLUDES BUT NOT LIMITED TO:**

- **PROPER ASSEMBLY, OPERATION, INSPECTION, MAINTENANCE, AND RELOCATION OF THE MACHINE.**
- **PROPER TRAINING FOR THE OPERATORS AND ENSURES THIS MANUAL IS AVAILABLE AT ALL TIMES.**
- **USAGE AUTHORIZATION.**
- **USAGE OF SAFETY AND PROTECTION DEVICES.**

**OLIVER MACHINERY DISCLAIMS ANY LIABILITY FOR MACHINES THAT HAVE BEEN ALTERED OR ABUSED. OLIVER MACHINERY RESERVES THE RIGHT TO EFFECT AT ANY TIME, WITHOUT PRIOR NOTICE, THOSE ALTERATIONS TO PARTS, FITTINGS, AND ACCESSORY EQUIPMENT WHICH THEY MAY DEEM NECESSARY FOR ANY REASON WHATSOEVER.**

**\*\* SAVE THIS MANUAL FOR FUTURE REFERENCES. \*\***

## **PROP 65 NOTICE**

**WARNING:** Drilling, sawing, sanding, or machining wood products can expose you to wood dust, and/or other chemicals that are known to the State of California to cause cancer, birth defects, or other reproductive harm.

Some examples of these chemicals are:

- Lead from lead-based paints.
- Crystalline silica from bricks, cement, and other masonry products.
- Arsenic and chromium from chemically treated lumber.

Avoid inhaling wood dust and other harmful chemicals. Use a dust mask and/or other safety devices for personal protection.

For more information go to <http://www.P65Warnings.ca.gov/wood>

# Table of Contents

<b>Introduction</b> .....	<b>5</b>	<b>Preparation before Sanding</b> .....	<b>28</b>
<b>Specifications</b> .....	<b>6</b>	Material Selection and Inspection .....	28
<b>Identification</b> .....	<b>8</b>	Supporting Large Workpiece.....	28
<b>Safety</b> .....	<b>10</b>	Safety Devices .....	28
General Safety Guidelines.....	10	Clear the Work Area.....	28
Safety Guidelines Specific to Sander.....	12	<b>Adjustments</b> .....	<b>29</b>
<b>Electricals</b> .....	<b>13</b>	Platen Angle Adjustment .....	29
Minimum Circuit Size Required for Model		Table Height Adjustment .....	29
6305 Sander .....	13	<b>Edge Sanding</b> .....	<b>30</b>
Grounding.....	13	<b>Horizontal Sanding</b> .....	<b>31</b>
Electrical Wiring .....	14	<b>Contour Sanding</b> .....	<b>32</b>
<b>Setup</b> .....	<b>15</b>	<b>Accessories</b> .....	<b>33</b>
Shop Preparation.....	15	<b>Maintenance</b> .....	<b>34</b>
Receiving.....	16	Changing Sanding Belt .....	35
Inventory .....	17	Inspect / Adjust Belt Tracking .....	36
<b>Initial Assembly</b> .....	<b>19</b>	<b>Troubleshooting</b> .....	<b>37</b>
Rubber Feet Installation .....	19	<b>Wiring Diagrams</b> .....	<b>39</b>
Cabinet Assembly.....	20	<b>Parts List</b> .....	<b>40</b>
Mounting Sander .....	22	Table and Base .....	40
Cleaning.....	22	Stand .....	41
Sanding Belt Installation.....	23	Motor and Sander Assembly .....	42
Stop Bracket Installation .....	24	End Table .....	43
Set Up Contour Sanding Table .....	25	<b>Maintenance Record</b> .....	<b>47</b>
<b>Dust Collection</b> .....	<b>26</b>	<b>Notes</b> .....	<b>48</b>
Test Run .....	27	<b>Warranty and Service</b> .....	<b>49</b>
<b>Operation</b> .....	<b>28</b>		

---

# Introduction

Thank you for choosing Oliver! This manual contains important information on how to safely set up, operate, and maintain this machine. Please take the time to read through this manual, and make sure you understand all instructions.

While this manual may provide tips on optimizing the result of your workpiece, the manual is not intended as a substitute for formal woodworking training. If you need to know how to safely complete a woodworking task, please consult knowledgeable and qualified sources before proceeding further.

We made every effort to keep this manual up-to-date. Instructions, specifications, drawings, and photographs in this manual should match the machine delivered. If you find any differences or anything that seems confusing in this manual, please check our website for an updated version:

## [WWW.OLIVERMACHINERY.NET/MANUALS](http://WWW.OLIVERMACHINERY.NET/MANUALS)

Alternatively, you can contact our technical support for help:

**1-800-559-5065**

Before calling, please note down the manufacture date and the serial number of the machine. You can find the information on a nameplate located on the back of the machine cabinet. This information is needed to provide proper technical support, and to determine if an updated manual is available for your machine.

Please let us know how well this manual serves you. If you have any suggestions, please call the number above or email us at:

**[info@olivermachinery.net](mailto:info@olivermachinery.net)**

We love to hear from our customers and make improvements.

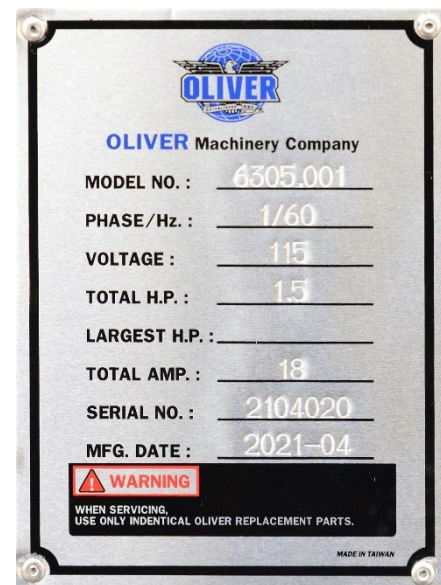

# Specifications

## Quick View

Model	6305 Sander
Stock Number	6305.001
Power Requirement	115V / 230V, 1Ph, 60Hz
Motor	TEFC 1.5HP, 115V / 230V, 1Ph
Sanding Belt Size	6" x 89"
Sanding Belt Tilt	0° - 90°
Dimensions	52-1/2"(W) x 23"(D) x 48"(H)
Footprint	21-1/2"(W) x 16-1/2"(D)
Fully Assembled Weight	246 lbs.
Warranty	1 Year (Motor and electronics) 2 Years (All other parts)

## Product Dimensions

Width x Depth x Height (Fully Assembled)	52-1/2"(W) x 23"(D) x 48"(H)
Footprint	21-1/2" (W) x 16-1/2"(D)
Fully Assembled Weight	246 lbs.

## Shipment Info

Packaging	Cardboard Box and Pallet
Content	Sander with Included Accessories
Dimensions	48"(L) x 27"(W) x 21"(H)
Weight	264 lbs.
Approx. Assembly Time	60 Minutes
Must Ship Upright	YES
Stackable	NO

## Electricals

Power Requirement	115V / 230V, 1Ph, 60Hz
Prewired Voltage	115V
Full Load Current Rating	18A @ 115V, 9A @ 230V
Recommended circuit size	20A @ 115V, 15A @ 230V
Power Switch Type	ON/OFF Button Switch
Connection Type	NEMA 5-15 Plug with 6' 14AWG Cord

### Motor

Motor Type	TEFC
Horsepower	1.5HP
Power Requirement	115V / 230V, 1Ph, 60Hz
Full Load Current Rating	18A @ 115V / 9A @ 230V
Speed	3450 RPM
Efficiency / Power Factor	75% / 90%
Power Transfer Mechanism	Direct Drive
Bearing type	Permanently Sealed Ball Bearing

### Sander

Sanding Belt Size	6" x 89"
Sanding Belt Speed	3900FPM
Sanding Belt Tilt	0° - 90°
Sanding Belt Drum Material	Aluminum
Platen Construction	Steel with Graphite Coating
Platen Dimensions	32-1/2" x 7"

### Table

Material	Precision Ground Cast Iron
Main Table Dimensions	29-3/4"(W) x 10"(D)
Main Table Height from Floor	37-3/4" – 40-3/4"
Miter Slot Type	T-Slot (Standard Size)
Miter Slot Size (W x H)	3/4" x 3/8"
Contour Sanding Table Dimensions	11-3/8"(W) X 9-1/4"(D)
Contour Sanding Table Height from Floor	38" – 43"
Fence Size	2-1/2" x 23-1/2"

### Miter Gauge

Angle Range	-30° to 30°, with positive stops at -45°, 90°, 45°
Miter bar Length	8-3/4"

### Safety

Number of Dust Ports	1
Dust Port Size	4"
Minimum CFM Required	650 CFM
Sound Rating @ 2' distance	100 dB

### Others

Serial Number Location	On the back of the machine stand.
Certification	CSA 175381
Country of Origin	Taiwan

# Identification

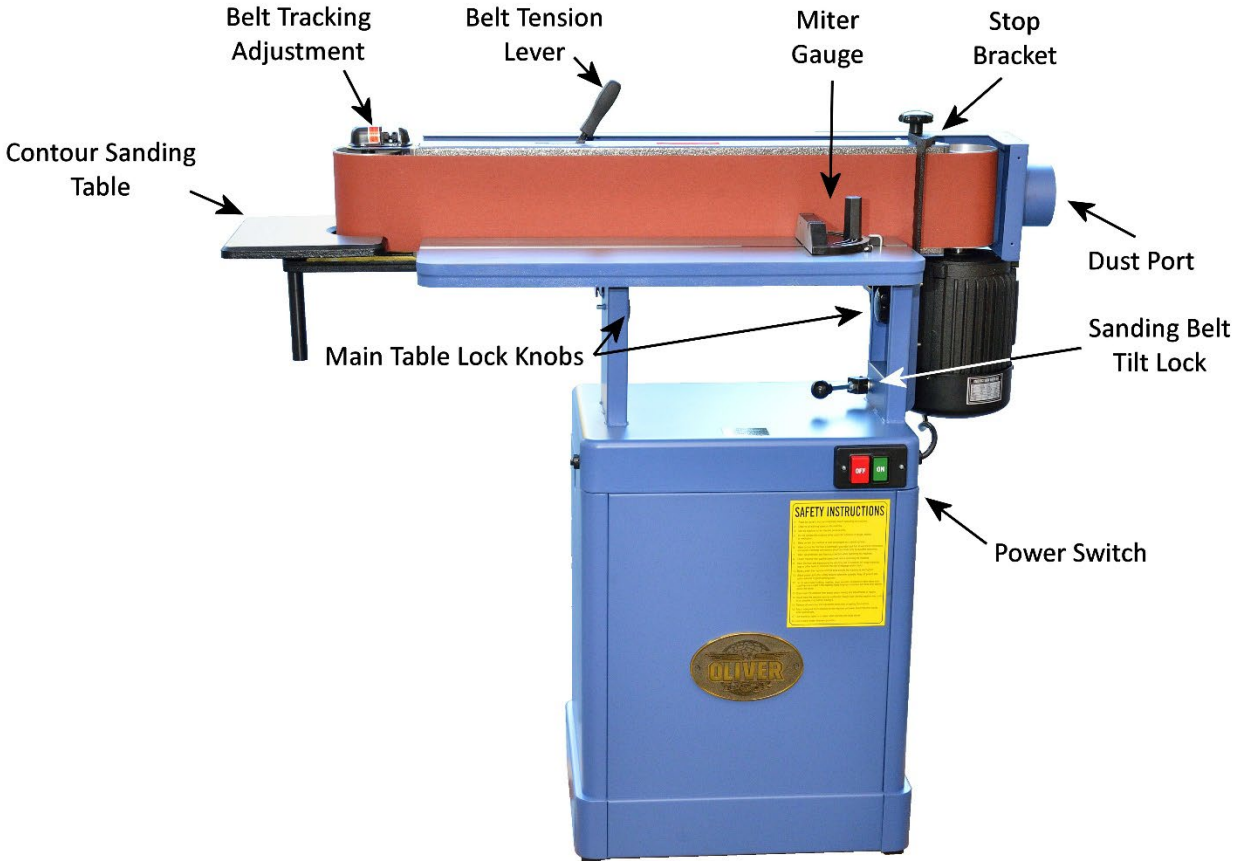



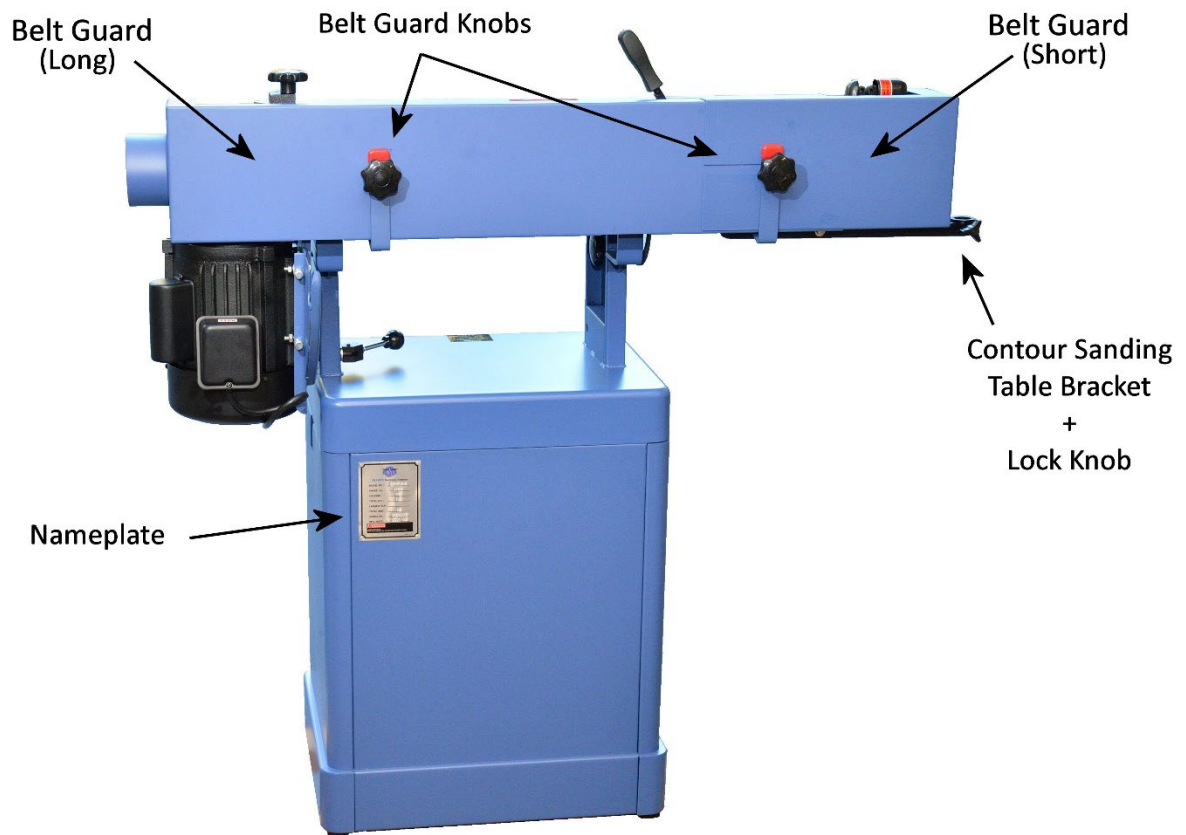



# Safety

Oliver Machinery has made every attempt to provide a safe, reliable, easy-to-use piece of machinery. Safety, however, is ultimately depending on the individual machine operator. **Before operating this machine, please become familiar with the following safety labels and guidelines.**

 <b>DANGER</b>	This indicates an imminently hazardous situation which, if not avoided, <b>WILL</b> cause death or serious injury.
 <b>WARNING</b>	This means if the warning is not taken seriously, it <b>CAN</b> cause death or serious injury.
 <b>CAUTION</b>	This means if the precaution is not taken, it <b>MAY</b> cause minor or moderate injury.
<b>IMPORTANT</b>	This is a tip for properly operating the machine to avoid machine damage.

## General Safety Guidelines

- FAMILIARIZE** yourself with all safety instructions found in this manual. Know the limitations and hazards associated with this machine. Do not operate/service this machine until you are properly trained.
- ELECTRICAL GROUNDING**, when done properly, reduce the risk of electrocution, shocks, and fire. Make certain that the machine frame is electrically grounded and that a ground lead is included in the incoming electrical service. In cases where a cord and a plug are used, make certain that the grounding plug connects to a suitable ground. Follow the grounding procedure indicated in the electrical code of your area.
- DISCONNECT** the machine from power before performing any service, maintenance, adjustments, or when changing cutters. A machine under repair should be RED TAGGED to show it should not be used until the maintenance is complete.
- EYE PROTECTION:** Always wear an approved safety face shield, goggles, or glasses that complies with ANSI Z87.1 and CSA Z94.3 standards. Common eyeglasses are not safety glasses, and may not provide adequate protection.
- EAR PROTECTION:** Use hearing protective devices where the noise exceeds the level of exposure allowed in Section 1910.95 of the OSHA Regulations. When in doubt, use it.
- OTHER PERSONAL PROTECTION:** Before the operation, remove tie, rings, watch, and other jewelry. Roll up sleeves above elbows. Remove all loose outer clothing and confine long hair. Protective footwear should be used. Do not wear gloves unless it is instructed to perform a particular step(s) in the manual.
- GUARDS:** Keep machine guards in place for all applicable operations. If any guards are removed for maintenance, DO NOT OPERATE the machine until all guards are reinstalled. Check clearance between the guards and the cutter before starting the machine.

8. **WORKPLACE SAFETY:** Keep the floor around the machine clean. Scrap material, sawdust, oil, and other liquids increase the risk of tripping or slipping. Be sure to clean up the table before starting the machine. Make certain the work area is well lighted and that a proper exhaust system is used to minimize dust. Use anti-skid floor strips on the floor area where the operator normally stands and mark off the machine work area. Provide adequate workspace around the machine.
9. **ACCESS CONTROL** should be enforced so only trained personnel can access the work area and operate the machine. Use a childproof power switch when applicable.
10. **STAY ALERT** at all times. Do not operate this machine while under the influence of drugs/alcohol, or when not feeling well.
11. **NEVER STAND ON THE MACHINE.** This prevents injuries from tipping related accidents and accidental contacts with cutters.
12. **REPLACEMENT PARTS:** Use only genuine Oliver Machinery replacement parts and accessories recommended for this machine. Generic parts made by other manufacturers may create a safety hazard and WILL void the factory warranty and other guarantees.
13. **PROPER USE:** Do not use this machine for anything other than its intended use. If used for other purposes, Oliver Machinery disclaims any real or implied warranty and holds itself harmless for any injury or damage which may result from that use.
14. **ADDITIONAL SAFETY INFORMATION:**
  - National Safety Council – *Accident Prevention Manual for Business and Industry:*  
<https://shop.nsc.org/apm-admin-program-14ed>
  - ANSI 01.1: <https://webstore.ansi.org/standards/wmma/ansio12013>
  - OSHA 1910.213: <https://www.osha.gov/laws-regs/regulations/standardnumber/1910/1910.213>

## Safety Guidelines Specific to Sander

### Before Work Begins:

1. Inspect the sanding belt for signs of failure. Replace damaged, overstretched, or worn sanding belts.
2. Ensure the sanding belt is tensioned.
3. Inspect the workpiece. Do not process workpieces with loose parts and/or containing dangerous chemicals. Do not sand wood with high moisture content.
4. Ensure the table is positioned at least 1/16" above the bottom edge of the sanding belt.
5. Ensure the sanding belt guard and the table are locked into position.

### When Sanding:

1. Maintain control of the workpiece. Hold the workpiece firmly with both hands and apply light pressure against the sanding belt. Use the sander table, backstop, miter gauge, or fence to support the workpiece in different operations.
2. Keep hands away from the sanding belt and other moving parts. Use special jigs to hold down small workpieces as needed.
3. To avoid kickbacks and sanding belt damages, do not feed the workpiece with sharp corners pointing against the moving direction of the sanding belt.

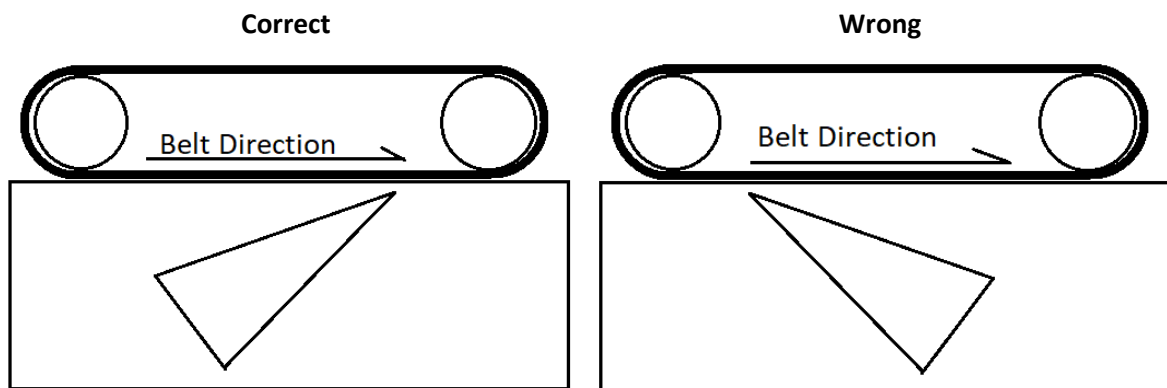

### After Operation

1. STOP THE MACHINE when the operator leaves the machine for any reason.
2. WAIT until the motor comes to a complete stop.
3. CLEAN UP before departure.

# Electricals

 <b>WARNING</b>	<b>All electrical work must be done by a qualified electrician and must meet the electrical code in your area.</b>
---	--

### Minimum Circuit Size Required for Model 6305 Sander

<b>Stock Number</b>	<b>Voltage</b>	<b>Minimum Circuit Size Required</b>
6305.001	115V	20A
	230V	15A

Please ensure the electrical circuit for this machine meets the minimum circuit size requirement. The minimum circuit size requirement applies to a dedicated circuit that provides power to one 6305 Sander. If more machines are sharing the same circuit, consult a qualified electrician to ensure the designated circuit is properly sized for safe operation.

If a circuit is available, but not meeting the minimum circuit size requirement listed above, a new circuit must be installed for this machine.

### Grounding

 <b>WARNING</b>	<b>Improper grounding can cause electric shock, fire, and equipment damage.</b>
---	---

Proper grounding reduces the risk to the operator in the event of electrical malfunction or breakdown. This machine must be connected to the grounding conductor when available, and all grounding connections must meet or exceed the electrical code requirements in your area. Furthermore, all grounds must be verified and must meet or exceed the electrical requirement of the machine. If grounding is not available, consider the use of a GFCI protection device as an alternative, if this complies with the electric code in your area.

## Electrical Wiring

This machine is pre-wired for 115V, with a cord and a NEMA 5-15 plug. Please refer to section “Wiring Diagrams” on page 39 for rewiring this machine for 230V operations. A 230V compatible plug is required.

Use of extension cord is not recommended. If you need to use an extension cord to connect to a power source, select a durable cord type with a high-temperature rating (90C° or above). Use the minimum amount of extension cord as needed.

### Minimum cord size (AWG) required based on amperage draw and length of the cord:

<i>Amps</i>	<b>Power Cord Length</b>			
	25 feet	50 feet	75 feet	100 feet
<i>8 to 12</i>	14	14	12	10
<i>12 to 15</i>	12	12	10	10
<i>15 to 20</i>	10	10	10	NR
<i>21 to 30</i>	10	NR	NR	NR

\*NR: Not Recommended



**Use properly sized wires that meet or exceed the power requirement of your machine. Using undersized wires may cause overheating and increase the risk of fire and machine damage.**

# Setup

## Shop Preparation

### Space Requirement

The dimensions of this machine are 52-1/2"(L) x 23"(W). You will need additional space for manipulating your workpiece, electrical connection, and dust collection.

Keeping this sander several feet away from the wall allows easy access to the belt guard for changing the sanding belt. This also allows you to operate on the backside of the machine with the sanding belt in a horizontal position.



Mounting this sander on a sturdy mobile base with lockable casters can be helpful for workshops with limited space.

### Load Limits

This machine has a shipping weight of 264 lbs., and a net weight of 246 lbs. Please ensure all lifting tools and building structures have adequate load capacity, for transporting and supporting the total weight of this machine, the operator, and related items.

### Electricals

Make sure a properly sized circuit and electrical outlet are available near the machine. Please refer to section "Electricals" on page 13 for details regarding electrical requirements.

### Lighting

Adequate lighting is needed for operating this machine. Overhead, non-glare lighting should be installed.

### Safety Labels

If this machine introduces a new safety hazard to your workplace. Please display proper warning signs in a highly visible location(s).

### Dust Collection

Wood dust created by this sander is a health hazard. High-quality dusk masks should be available for using the sander.

Connect this machine to a dust collection system. Check air suction strength regularly to ensure dust and shavings are effectively removed.



**Air resistance and leakage in a dust collection system impact its effectiveness. Use a dust collection system that is rated above 650 CFM at the dust port. Doing so improves air quality in the workplace, and prevents the machine from jamming.**

## Receiving

Your shipment should come in one box. Upon receiving your shipment, check for any significant damages before signing the delivery confirmation.

### **IMPORTANT**

If items are damaged, please call us immediately at **1-800-559-5065**



Always wear safety goggles and gloves when removing straps for securing your package. Strapping may spring back violently when released and cause injury.

## Moving Machine into the Shop

Your machine will be delivered by freight service, and it will be left outside of your workshop by default. On the day of delivery, please be sure help is available to move the machine to its final location.



6305 Sander has a gross weight of 264 lbs. and a net weight of 246 lbs.

Safe moving techniques and proper lifting equipment are required, or serious personal injury may occur.



Your machine may be secured by the straps. Do not lift your shipment by the strap. They are not designed to hold the total weight of your shipment. They may snap without warning and cause serious injury and machine damage.

## Unboxing

You should find the sander assembly and other parts packed inside the box.





## Inventory

Carefully unwrap the packaging and make sure all components are included in the shipment. Inventory all items received and put them in groups.

### Group 1 - Parts for rubber feet installation

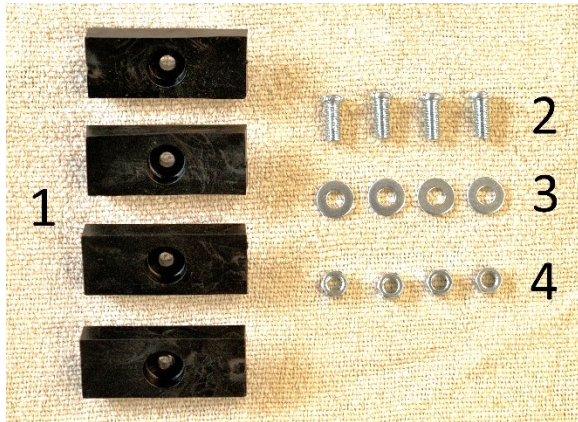

Item	Description	Quantity
1	Rubber Feet	4
2	Round Head Screws (5/16"-18*3/4")	4
3	Washers (5/16")	4
4	Nuts (5/16")	4

### Group 2 – Cabinet mounting hardware

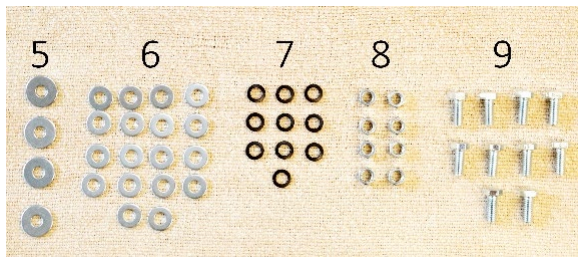

Item	Description	Quantity
5	Fender washers (5/16")	4
6	Washers (5/16")	18
7	Lock washers (5/16")	10
8	Hex nuts (5/16")	8
9	Hex nuts (5/16")	10

### Group 3 – Cabinet panels



### Group 4 – Stop bracket



### Group 5 – Contour sanding table and accessories

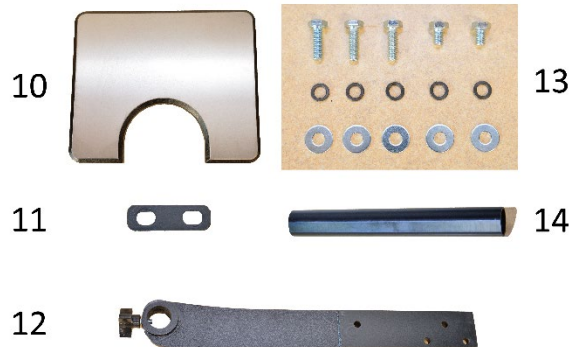

Item	Description	Quantity
10	Contour sanding table	1
11	Mounting Bracket	1
12	Contour sanding table bracket	1
13	Mounting hardware	1 set
14	Support rod	1

**Group 6 – Knobs**



**Group 8- Belt tracking adjustment tool**



**Group 7 - Belt tensioner handle**



**Group 9 – Miter gauge**

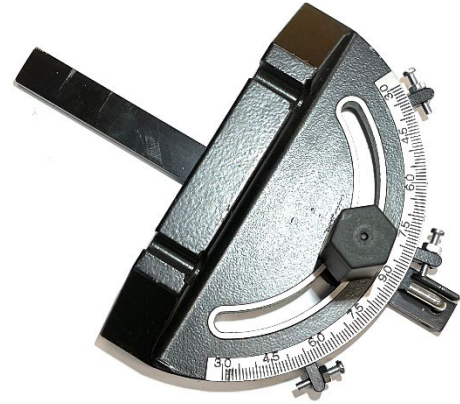

**NOTICE:** If you cannot find an item in the list above, please check if it is still attached to the packaging. Occasionally the item may have been pre-installed in the factory. See section “Parts List” to check if a component is included or installed.

**NOTICE:** This machine comes with various standard-sized, non-proprietary parts. If any of these parts are missing, we are happy to deliver them to you. To have the machine up and running as soon as possible, you can also find these parts at your local hardware store.

**Additional Items Needed for Machine Assembly**

<i>Item</i>	<i>Purpose</i>
Safety glasses	Protection
Disposable gloves	Protection
Paper Towel	Cleaning
WD-40	Cleaning
Rust Inhibitor	Cast iron table top rust protection.
12mm Wrench (1 Pair)	Machine Assembly
Straight Head Screw Driver	Machine Assembly
Philips Head Screw Driver	Machine Assembly

## Initial Assembly

### Rubber Feet Installation

1. Gather all hardware in “**Group 1**”

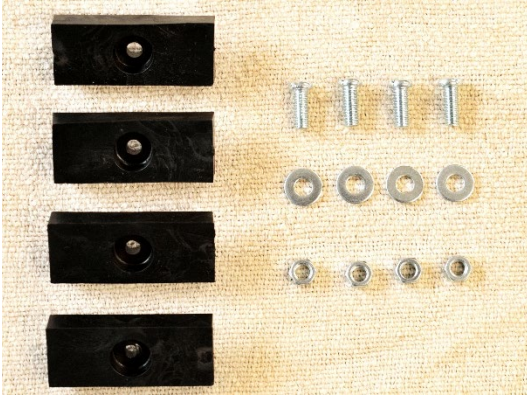

2. Insert a round head screw and a washer into the rubber feet.
3. Mount the feet at the bottom of the side panel. Thread a nut into the screw.

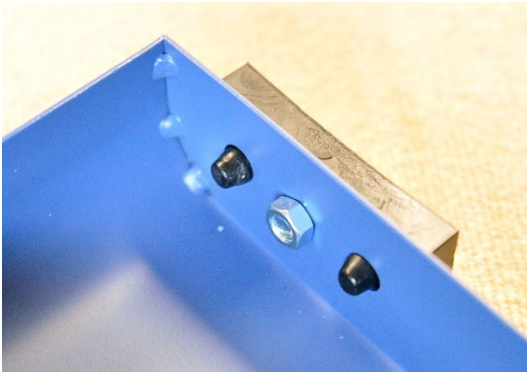

4. Hold the bolt in place while tightening the screw with a flat head screwdriver.



## Cabinet Assembly

For this step, you will need:

1. The panels with rubber feet already mounted:



2. All mounting hardware in "Group 2":

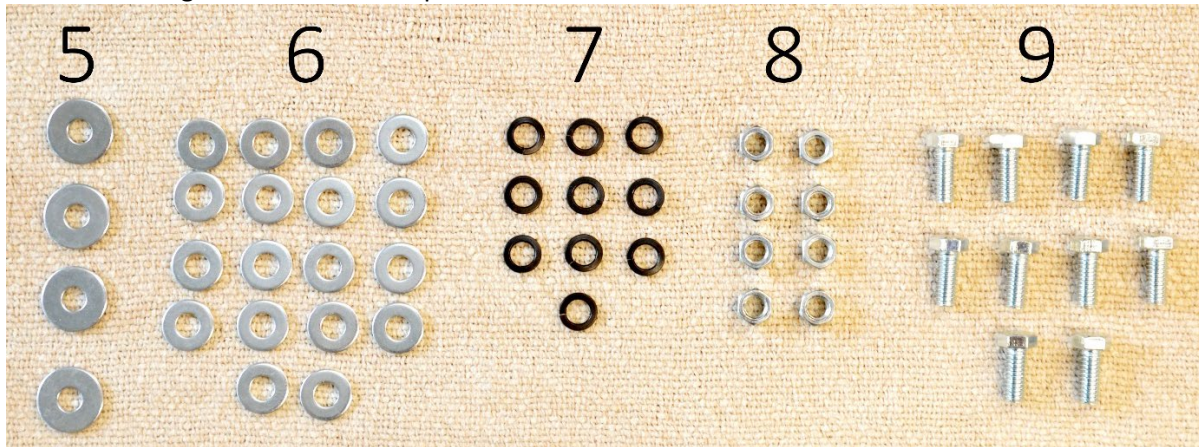

Item	Description	Quantity
5	Fender washers (5/16")	4
6	Washers (5/16")	18
7	Lock washers (5/16")	10
8	Hex nuts (5/16")	8
9	Hex nuts (5/16")	10

3. Attach the panels as illustrated in the diagram below. To make sure the top of the cabinet sits flush with the base of the sander assembly, it's recommended to install the panels upside down on a flat surface. Tighten the bolts to hold the panels together, but do not fully tighten them yet.

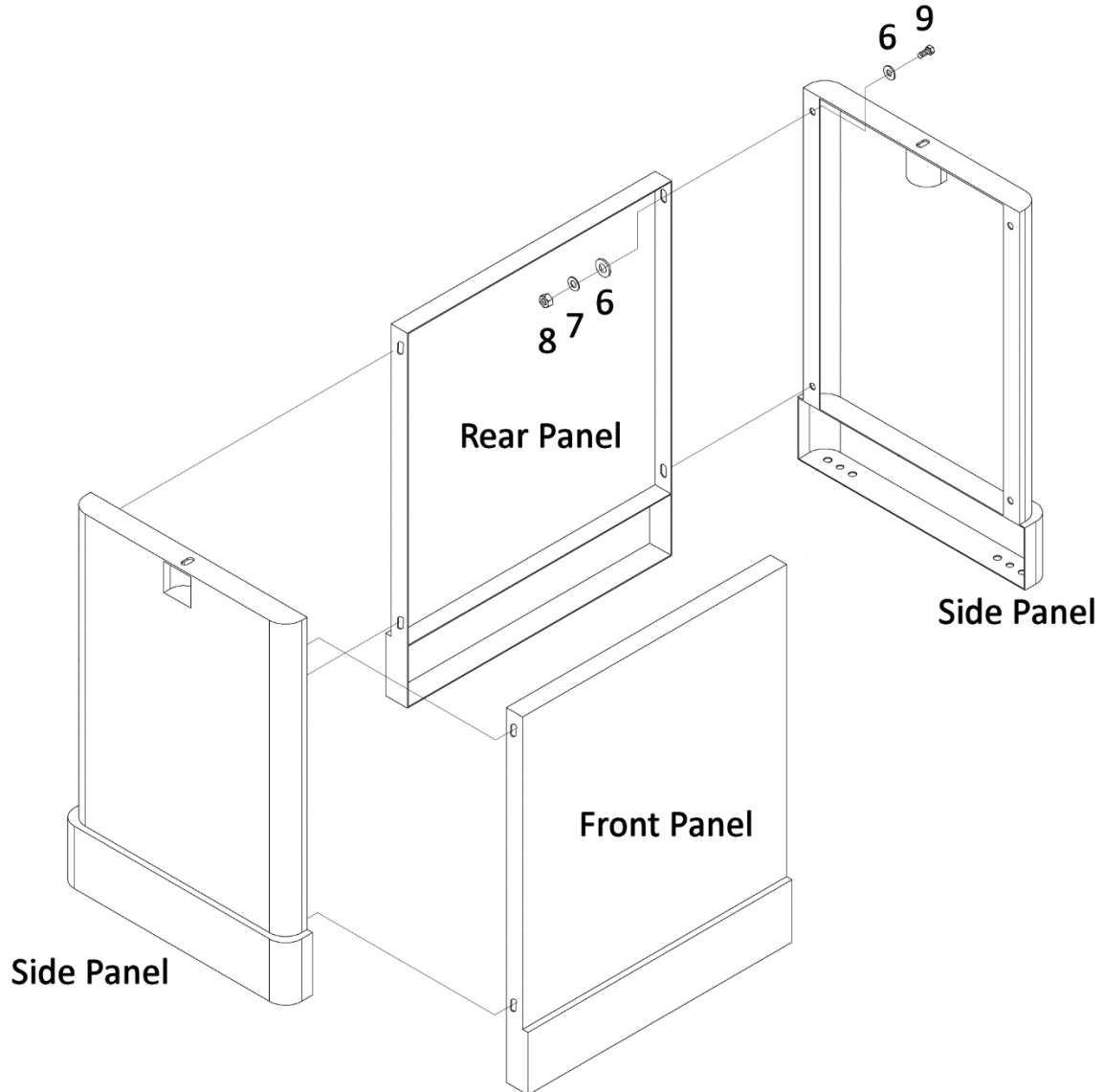

4. Place the cabinet right side up. Make sure it does not rock on the ground. Adjust the joints of the panels as needed. Fully tighten all the bolts before the next step.

## Mounting Sander



**WARNING**

The sander assembly is very heavy. Mounting the sander on the cabinet requires multiple people and/or equipment with adequate lifting power. Use proper lifting techniques and protective gear. Failure to comply can result in serious injury and machine damage.

1. With additional help, remove the sander assembly from the box.
2. Place the unit on top of the cabinet.



3. Align the screw holes of the sander assembly and the cabinet.
4. From the mounting hardware package, prepare two sets of flat washers (#6), lock

washers (#7), and 5/16" hex bolts (#9). Insert the lock washer into the bolt, and then the flat washer.

5. Secure the sander assembly on the cabinet. Tighten the bolt and washers with a 12mm wrench.

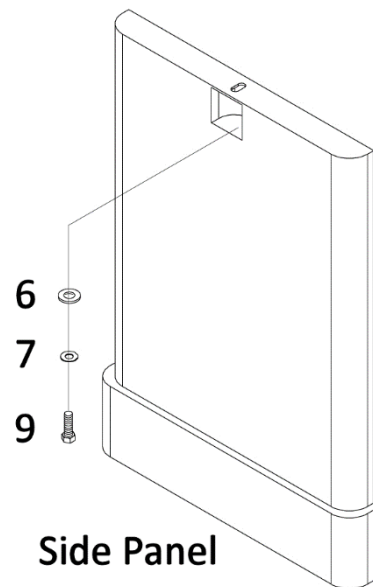

**Side Panel**

## Cleaning

To prevent rusting during shipment, the unpainted cast iron tabletops are covered with rust protectant and plastic film. Remove the plastic film and wipe off the rust protectant with paper towels. Using WD-40 can help to dissolve the rust protectant and make it easier to remove.

Once all rust protectant is removed, routinely coat the tabletops with rust preventive such as Boeshield® T-9 or paste wax. Do not use rust preventives that contain silicone, which is known to interfere with certain finishes and glues.

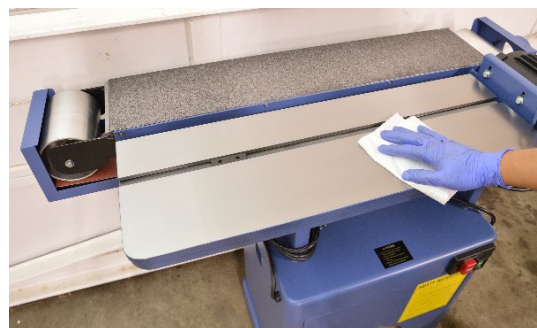

## Sanding Belt Installation

This sander is shipped with the platen in the horizontal position. Tilt the platen to the vertical position to install the sanding belt.

1. The platen lock lever is located below the table. Unlock the platen by pushing the lever towards the back of the machine. Tilt the platen to the vertical position and lock it in place.

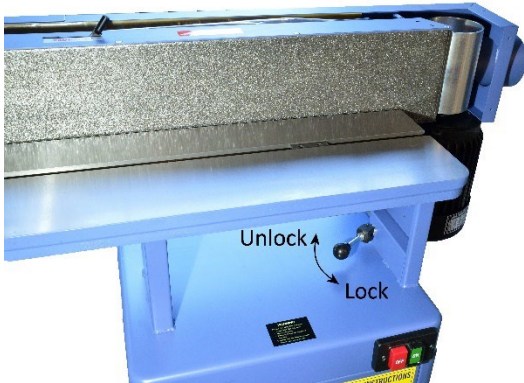

2. Loosen the belt guard lock knobs. Remove the short belt guard from the mounting brackets, then the long belt guard.



3. **Important:** Be careful when removing the belt guard as the fence and the sanding belt are loosely packed inside.



4. Install the belt tension lever handle that is located on the top of the platen assembly. Use a mallet to gently tap the handle into the lever.



5. Move the lever to the "Loose" position.

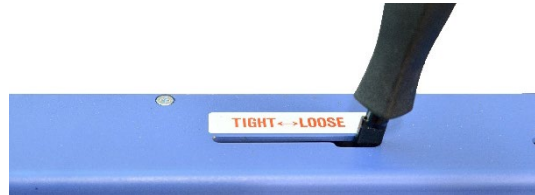

6. The sanding belt rotates counter-clockwise when the sander runs. Make sure the arrows on the back of the sanding belt align with the direction indicator.



7. Slip the belt evenly and gradually into both drums, until the belt is sitting in the middle of the drums.



8. Tighten the sanding belt by moving the belt tensioning lever back to the "Tight" position. When the sanding belt is properly tensioned, it should not slip off from the drums.
9. Reinstall the belt guard and tighten the lock knobs.

## Stop Bracket Installation

1. The stop bracket provides support to the workpiece and prevents the workpiece from getting dragged into the belt guard. It should be installed while the machine is in use.



2. The stop bracket mounting holes are located on top of the platen near the drive drum. Insert the stop bracket pin into the hole as shown in the picture.



3. Secure the bracket with a lock knob.

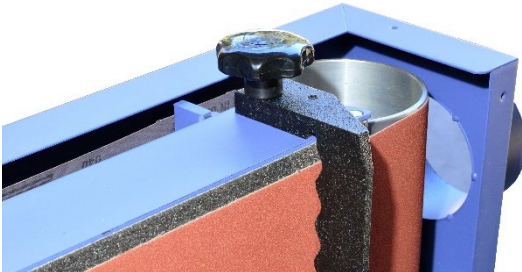



## Set Up Contour Sanding Table

1. Gather the table and all mounting hardware.



2. Locate the table bracket mounting points. It is at the bottom of the sander, right below the short belt guard.

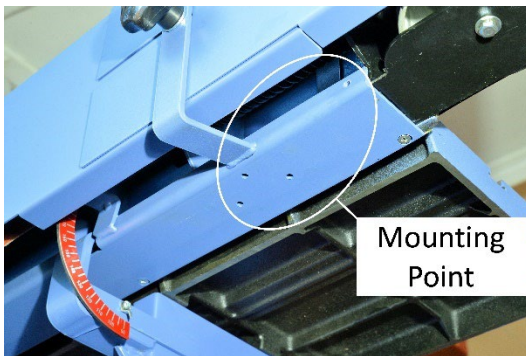

3. Mount the table bracket using the provided mounting hardware. Use the long bolts for the bottom holes. Then install the mounting bracket on the side using two short bolts.

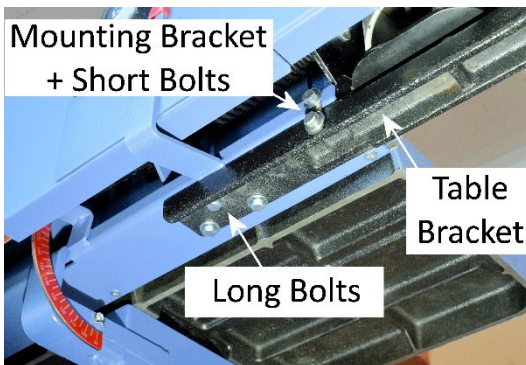

4. Install the table support rod. Make sure the machined-flat surface of the rod aligns with the locking bolt.

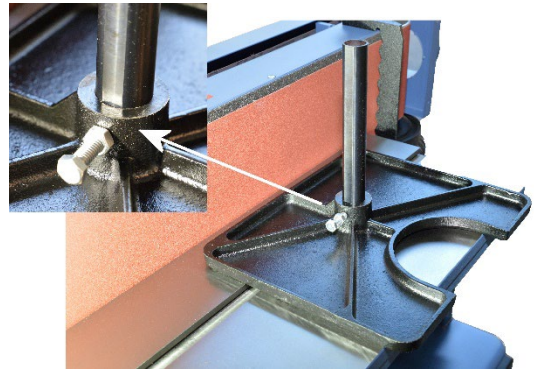

5. Remove the short belt guard.

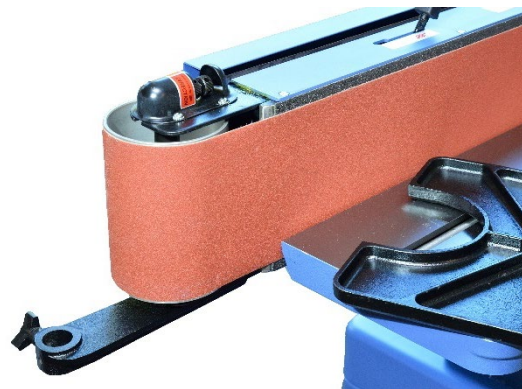

6. Insert the table assembly into the mounting bracket. Align the flat surface of the post with the lock knob. Ensure the table is not catching the sanding belt, then tighten the lock knob to secure the table.

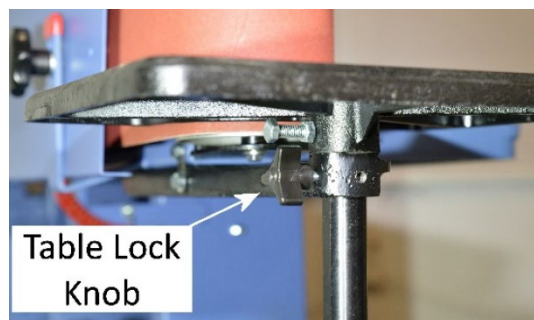

7. When the table is properly set up, loosen the table lock knob and remove the entire table assembly. When not using the contour sanding table, install the short belt guard to prevent accidental contact with the drum.

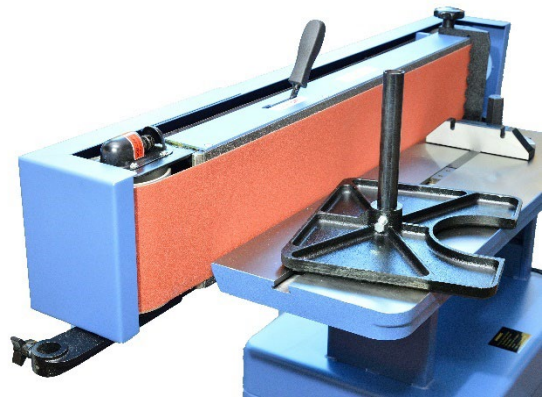

### Dust Collection

This sander can generate a lot of dust. Connect this machine to a dust collection system.

The minimum CFM requirement for this sander is 650 CFM at the dust port, which means the dust collection system should have a rating greater than 650 CFM, as air friction and leakage can reduce effective CFM at the dust port.



#### **IMPORTANT**

Running this sander without a dust collection system, or using a dust collection system with inadequate suction may damage the machine and cause other hazardous situations. Check your dust collection system regularly to make sure it is not jammed or filled up.

## Test Run

By completing the steps in the previous sections, the sander is ready for a test run.

1. Before connecting the sander to a power source, press the “OFF” button on the power switch to prevent the machine from starting unintentionally.
2. Make sure the platen is locked into position.
3. Tighten the lock knobs of the belt guard and the table.
4. Check belt tension. Make sure the sanding belt is not catching the guard and other stationary parts.
5. Connect the machine to power.
6. Turn on the machine. The sanding belt should track within the platen. If the sanding belt is not tracking properly, **TURN OFF MACHINE IMMEDIATELY**. See section “Inspect / Adjust Belt Tracking” on page 36.
7. Allow the machine to run for a minute. During the initial run, a small amount of loose graphite may fall off from the platen. That is part of the break-in process and it is expected. Remove the graphite flakes with a vacuum cleaner.
8. Turn off the sander to complete the test run.

Congratulations! You have completed the test run. If you discover any issues from the tests, refer to the troubleshooting section and maintenance section to diagnose issues and make adjustments.

# Operation

## Preparation before Sanding

### Material Selection and Inspection

This machine is primarily designed for sanding good quality natural wood materials. Avoid cracked stock, and boards with loose knots can break apart. These can cause severe kickbacks, which can lead to severe injuries and machine damage. Using this sander for other material types may damage the sanding belt or shorten its lifespan, and may cause other hazardous situations. For example, sanding ferrous metals can create sparks, and that can ignite flammable materials nearby.

Do not sand treated lumber or anything that contains harmful chemicals, as this will spread dust that contains such harmful chemicals.

Carefully inspect the workpiece for foreign objects. Nails, staples, rock chips, and other objects embedded on the wood surface can damage the sanding belt. Clean the workpiece with a stiff brush as needed.

Glue on the workpiece can gum up the sanding belt. Scrape off all excess glue before sanding.

The workpiece should have at least one flat surface so it can be pushed firmly against the table for feeding. Materials that do not have a flat surface should have the support surface flattened, or be handled with a special jig that stabilizes the workpiece for feeding.

### Supporting Large Workpiece

Supporting large workpieces with auxiliary support to avoid injuries and to create a consistent finish.

### Safety Devices

To reduce the chance of a workpiece getting pulled out of your hand, and to avoid accidental contact of the moving sanding belt, create special jigs to hold down workpieces that are less than 6" long, and for those that are difficult to feed steadily.

Always wear high-quality dust masks when operating the sander.

### Clear the Work Area

Before turning on the sander, make sure the sander table is free of debris, and the workpiece is not engaging the sanding belt.

## Adjustments

### Platen Angle Adjustment

The platen can be set vertically, horizontally, or in any position in between.

1. To adjust the platen angle, unlock the platen by pushing the lock lever towards the rear of the machine.
2. Set platen to the desired angle. Use a woodworking square or angle scale located below the table to confirm the settings.
3. Lock the platen by pulling the lock lever back to the locked position.



### Table Height Adjustment

#### To set the height of the main table:

1. Loosen the two lock knobs that are below the main table.



2. Adjust the table height. Make sure the table is positioned at least 1/16" above the bottom edge of the sanding belt, and it is level with the sanding belt.
3. Tighten the table lock knobs when adjustment is done.
4. **TIP:** Occasionally adjust the table height and make use of various sections of the sanding belt. This helps to even out the wearing of the sanding belt and extend its life.

#### To set the height of the contour sanding table:

1. Loosen the lock knob on the table bracket.

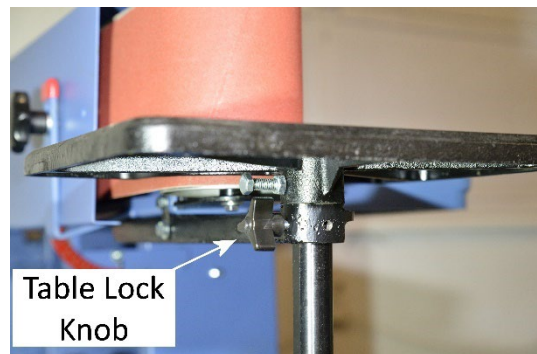

2. Adjust the table height. Make sure the table does not touch the abrasive surface and is positioned at least 1/16" above the bottom edge of the sanding belt.
3. Tighten the lock knob when adjustment is done.



**Position the table at least 1/16" above the bottom edge of the sanding belt. Doing so prevents materials or body parts from getting caught between the table and the belt, which can cause serious injury.**

## Edge Sanding

1. Move the platen to the vertical position to create a squared edge.

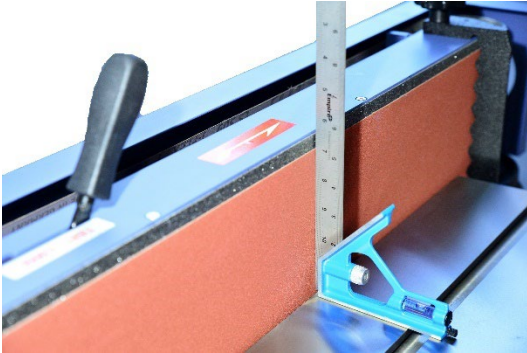

2. Install the stop bracket if it is not previously installed.
3. Adjust the table height as needed.
4. Using a miter gauge can provide additional support to the workpiece and create an angled end. This sander comes with a miter gauge that can be locked onto the miter slot. Adjust and check the miter angle against the sanding belt before use.



5. Before starting the sander, clear the table and turn on the dust collection system.
6. Turn on the sander.

7. Hold the workpiece firmly on the table and use a miter gauge or other devices as support when needed. Feed the workpiece gently to the sanding belt.



8. To shape or round corners, begin the operation from a trailing corner, and rotate the workpiece against the direction of the sanding belt.

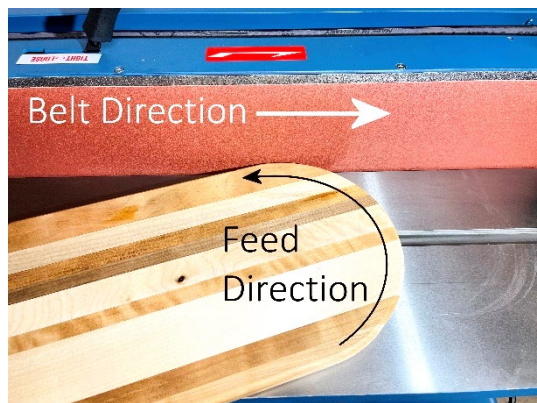

9. **WARNING:** Avoid feeding a sharp corner against the travel direction of the sanding belt. Doing so increases the risk of the workpiece pulling away from the operator, which may cause serious injuries and machine damage.

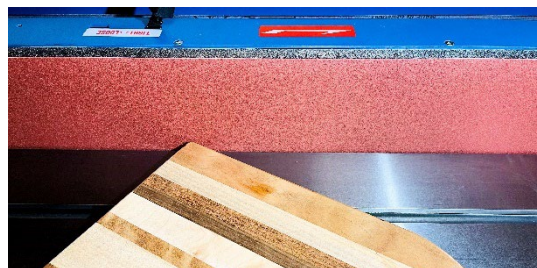

## Horizontal Sanding

1. Move the platen to the horizontal position.
2. Raise the main table so it is level or slightly above the sanding belt.

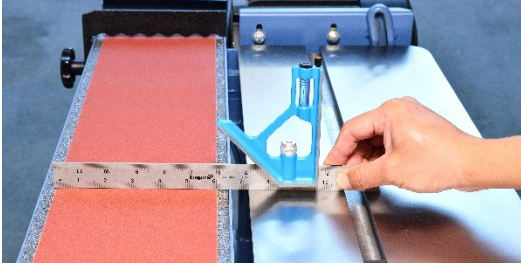

3. Install the stop bracket if it is not previously installed.
4. The fence that comes with this sander provides an additional surface to support the workpiece.
5. To install the fence, insert the guiding blocks into the miter slot, and align them with the fence's slots.

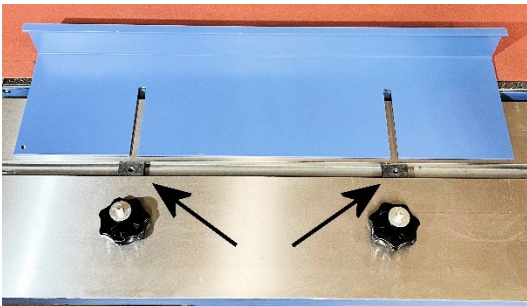

6. Secure the fence with two sets of flat washers and short lock knobs.



7. Gently feed the workpiece to the sanding belt.



8. Remain in full control of the workpiece and keep hands away from the abrasive surface. Use the fence and stop bracket to provide additional support when applicable.

## Contour Sanding

1. Remove the short belt guard.

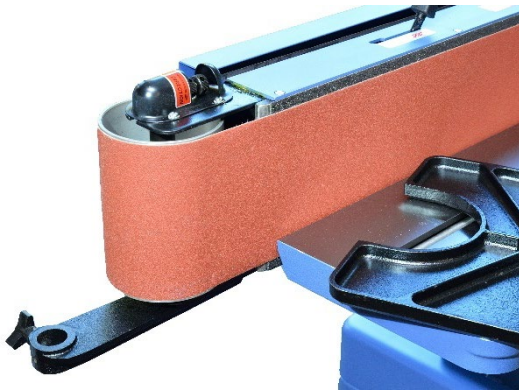

2. Insert the table assembly into the mounting bracket. Align the flat surface of the post with the lock knob.

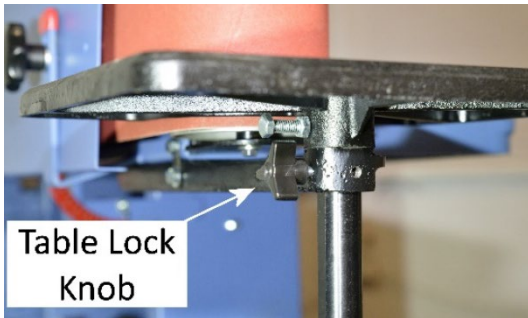

3. Ensure the table is not catching the sanding belt, then tighten the lock knob to secure the table.

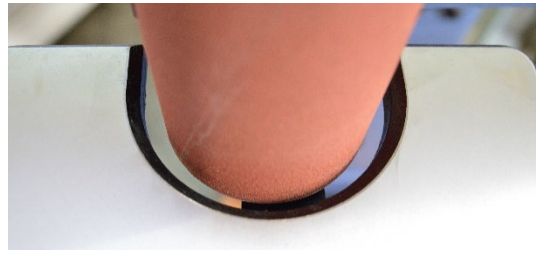

4. Remove the contour sanding table and reinstall the short belt guard when the operation completes.

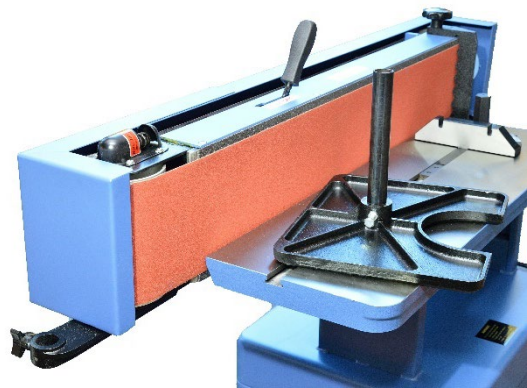

**WARNING**

Avoid sanding edges with curvature closely matching the abrasive surface. Failure to comply increases the risk of a catch, which can cause severe injuries and damage to the workpiece.



**IMPORTANT**

Only remove the short belt guard and install the contour sanding table while performing contour sanding. Keeping all belt guards installed at most times improves dust collection effectiveness for edge/horizontal sanding, and reduces the risk of accidental body contact with the sanding surface and moving parts.



# Accessories

## Touchup Paint



Keeping all painted surfaces in good condition not only makes your machine look nice but also keeps rusts away. Oliver Machinery has pre-mixed spray paint available in Oliver-Blue for purchase.

Accessories are available on our website: **OLIVERMACHINERY.NET**

To order by phone, please call us at **1-800-559-5065**. We are available Monday through Friday, 7:30 AM - 4 PM Pacific Time. You can also email us at **PARTS@OLIVERMACHINERY.NET** to purchase accessories.

Please visit our website at **OLIVERMACHINERY.NET** for additional recommended accessories.



**Using unapproved accessories may cause the machine to malfunction, which can result in serious injury and/or machine damage. Only use accessories recommended for this machine.**

# Maintenance

Routine maintenance keeps your sander in optimal condition. Please follow the maintenance schedule below, and use the maintenance record worksheet attached in the back of the manual to document all tasks completed.

**NOTICE:** Maintenance schedule may vary for individual users due to different situations and safety requirements.

Task	Frequency
Inspect power switch, cord, and plugs for signs of failure.	Every day before any operation begins.
Inspect the sanding belt for signs of failure.	Every day before any operation begins.
Clean sanding belt with belt cleaning stick.	When the sanding belt is clogged.
Remove dust accumulated on the machine.	Weekly
Apply rust protectant on cast iron tables.	Monthly
Inspect and clean sanding belt drums.	Monthly

 <b>WARNING</b>	<b>Disconnect the machine from the power source before any maintenance work is performed. After servicing the sander, remove all tools before restarting the machine. Failure to comply can cause serious injury!</b>
--	---

## Changing Sanding Belt

1. **Disconnect the machine from the power source.**
2. Move the platen to the vertical position and lock it in place. (See section – Platen Angle Adjustment on page 29 for details.)
3. Remove the stop bracket.
4. Loosen the belt guard lock knobs, then remove both belt guards.



5. Loosen the sanding belt by moving the belt tensioning lever to the “Loose” position.



6. Gently slide the sanding belt off the drums.

7. The sanding belt rotates counter-clockwise when the sander runs. Make sure the arrows on the back of the sanding belt align with the direction indicator.



8. Slip the belt evenly and gradually into both drums, until the belt is sitting in the middle of the drums.



9. Tighten the sanding belt by moving the belt tensioning lever back to the “Tight” position. When the sanding belt is properly tensioned, it should not slip off from the drums.
10. Reinstall the belt guards and the stop bracket. Tighten all lock knobs.

## Inspect / Adjust Belt Tracking

Run the sander for 5-10 seconds to observe the tracking of the sanding belt. The sanding belt should track in between the upper and the lower edges of the drums.

### If adjustment is needed:

1. Turn off the sander.
2. Loosen the lock nut
3. Rotate the belt tracking adjustment bolt UP to raise the belt on the drum, and DOWN to lower the belt on the drum.

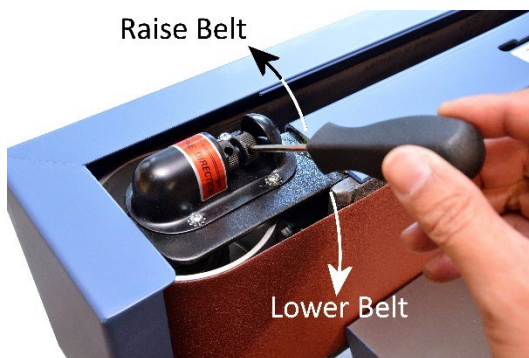

4. Adjust belt tracking by rotating the bolt 1/4 turn at a time. Tighten the lock nut and turn on the machine to verify the adjustment.
5. Repeat steps 1-4 as needed.

# Troubleshooting

## Mechanical / Electrical Issues

Problem	Possible Cause	Solution
<b>Machine will not start</b>	Not connected to a power source.	Make sure the machine is plugged in. Check the electrical panel for a tripped circuit breaker or a blown fuse. Ensure all electrical connections have good contacts.
	Low voltage / current.	Have an electrician check/repair the power circuit.
	Faulty switch/motor/capacitor.	Contact customer service for further assistance.
<b>Machine stopped during the operation.</b>	Tripped circuit breaker or blown fuse.	Reconnect circuit. Reduce feed pressure.
<b>Circuit breaker trips frequently</b>	Feeding stock too fast.	Reduce feed rate.
	Extension cord too light or too long.	Use a shorter / heavier cord that meets this machine's electrical requirements.
<b>Machine stalls or does not come up to speed</b>	Extension cord too light or too long.	Use a shorter / heavier cord that meets this machine's electrical requirements.
	Feeding pressure too high.	Reduce feed pressure.
	Motor not wired properly for the operating voltage.	Use the wiring diagram to properly wire up the motor.
	Motor/capacitor issue.	Contact customer service for further assistance.
<b>Machine vibrates excessively</b>	Machine stands on uneven floors.	Reposition machine on a flat, level surface.
	Low sanding belt tension.	Move tension lever to "Tight" position.
		Replace tension spring as needed.
	Worn/broken sanding belt.	Replace sanding belt.
	Improper motor/component mounting.	Check, adjust, and tighten motor/component mounting.
Motor bearing issue.	Contact customer service for further assistance.	

## Operation / Quality-Related Issues

Problem	Possible Cause	Solution
<b>Work pulled from hand</b>	Inadequate stock support.	Hold work firmly against the sanding belt. Use miter block, backstop, or fence as support. Use special jigs to support the short stock.
	Sanding belt is not perpendicular to the table.	Adjust sanding belt tilt.
	Improper stock feeding.	Ensure stock is pressed firmly against the table when feeding.
<b>Stock burns</b>	Sanding grit is too fine.	Use a sanding belt with a coarser grit.
	Clogged/worn sanding belt.	Use the sanding belt cleaner to unclog the belt. Replace the sanding belt as needed.
	Feed pressure too high.	Lower feed pressure.
<b>Sanding belt clogs easily</b>	Sanding softwood or wood with high resin content.	Clean/replace the belt more frequently.
	Sanding wet stock.	Dry stock before sanding.
	Sanding non-wood materials.	Some materials may melt easily when heated. Sand with light pressure and keep it cool when sanding.
<b>Deep sanding marks on the workpiece</b>	Sanding belt grit is too coarse.	Use a finer grit sanding belt.
	Dirty/contaminated sanding belt.	Clean sanding belt. Replace as necessary.
	Too much feeding pressure and/or abrupt feeding.	Reduce feeding pressure and allow more time for the abrasive surface to work on the workpiece.
<b>Abrasive materials rub off the belt easily</b>	Aged sanding belt.	Avoid storing sanding belts in extreme temperature and humidity which may cause the belt to fail prematurely. Do not fold or smash the sanding belt as it may disintegrate the bonding material on the belt.

# Wiring Diagrams

115V Wiring

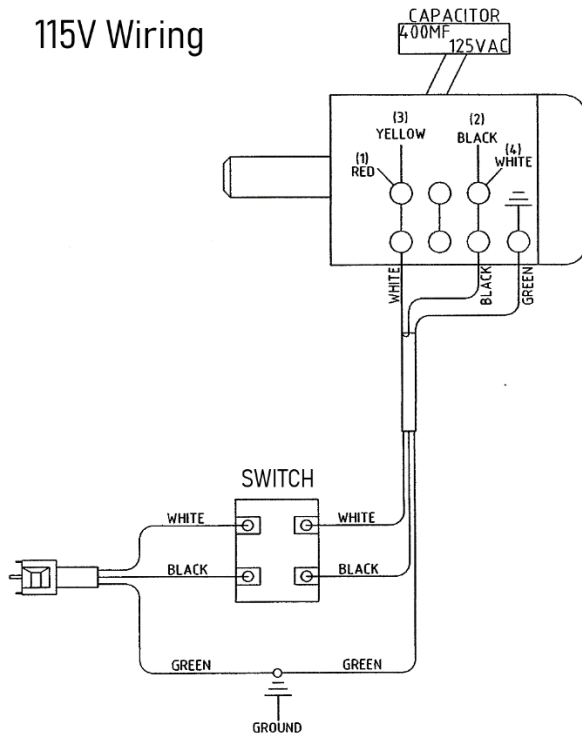

230V Wiring

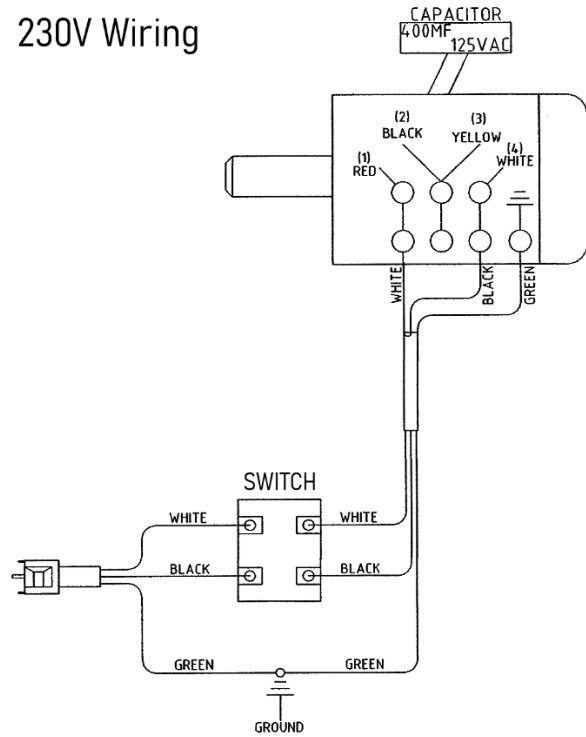

**Deenergize the electrical circuit before touching any enclosed, electrified parts. Touching an electrified part WILL result in serious personal injury or death.**



**All electrical work must be done by a qualified electrician and must meet the electrical code in your area.**

# Parts List

## Table and Base

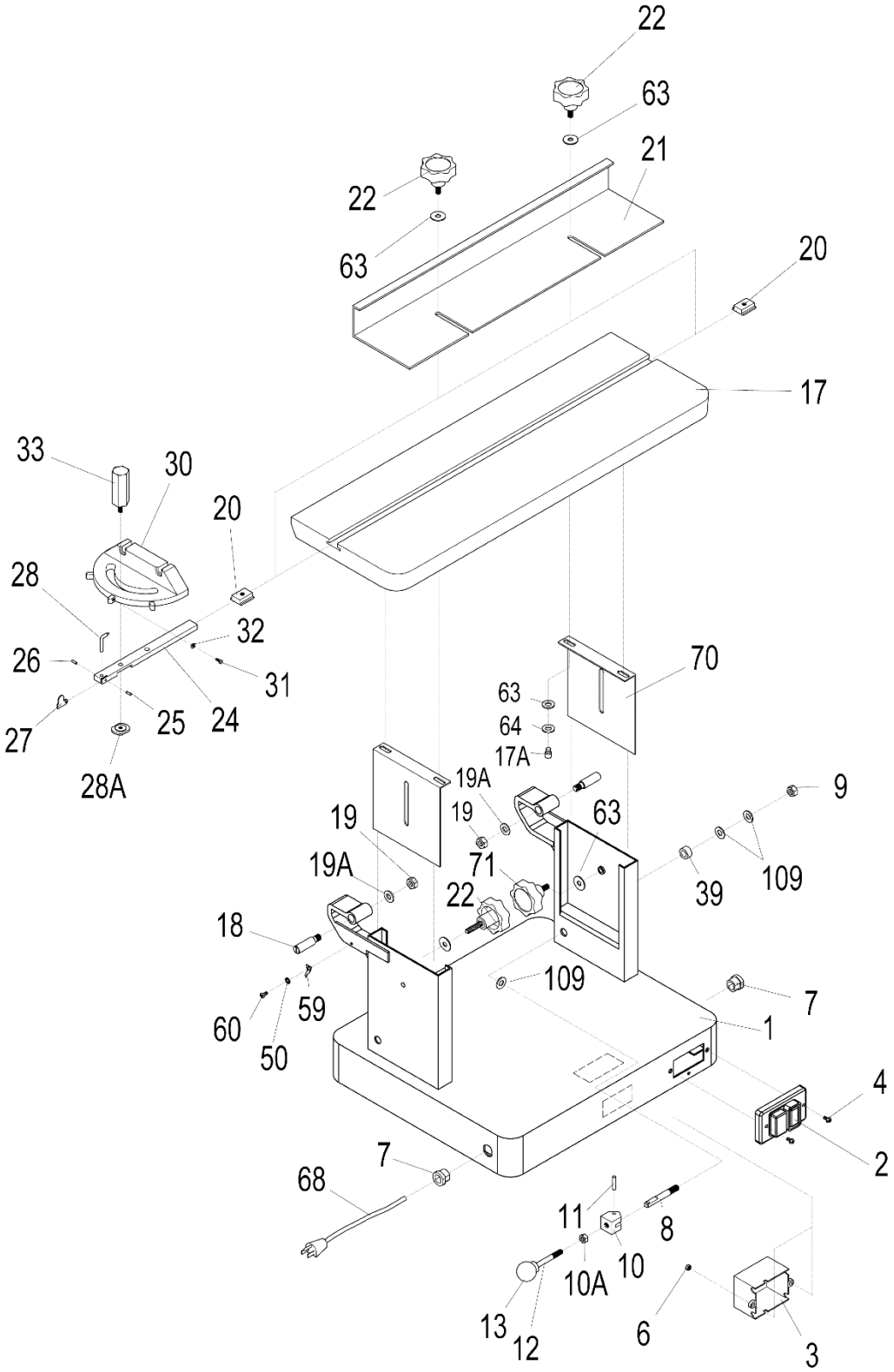



Stand

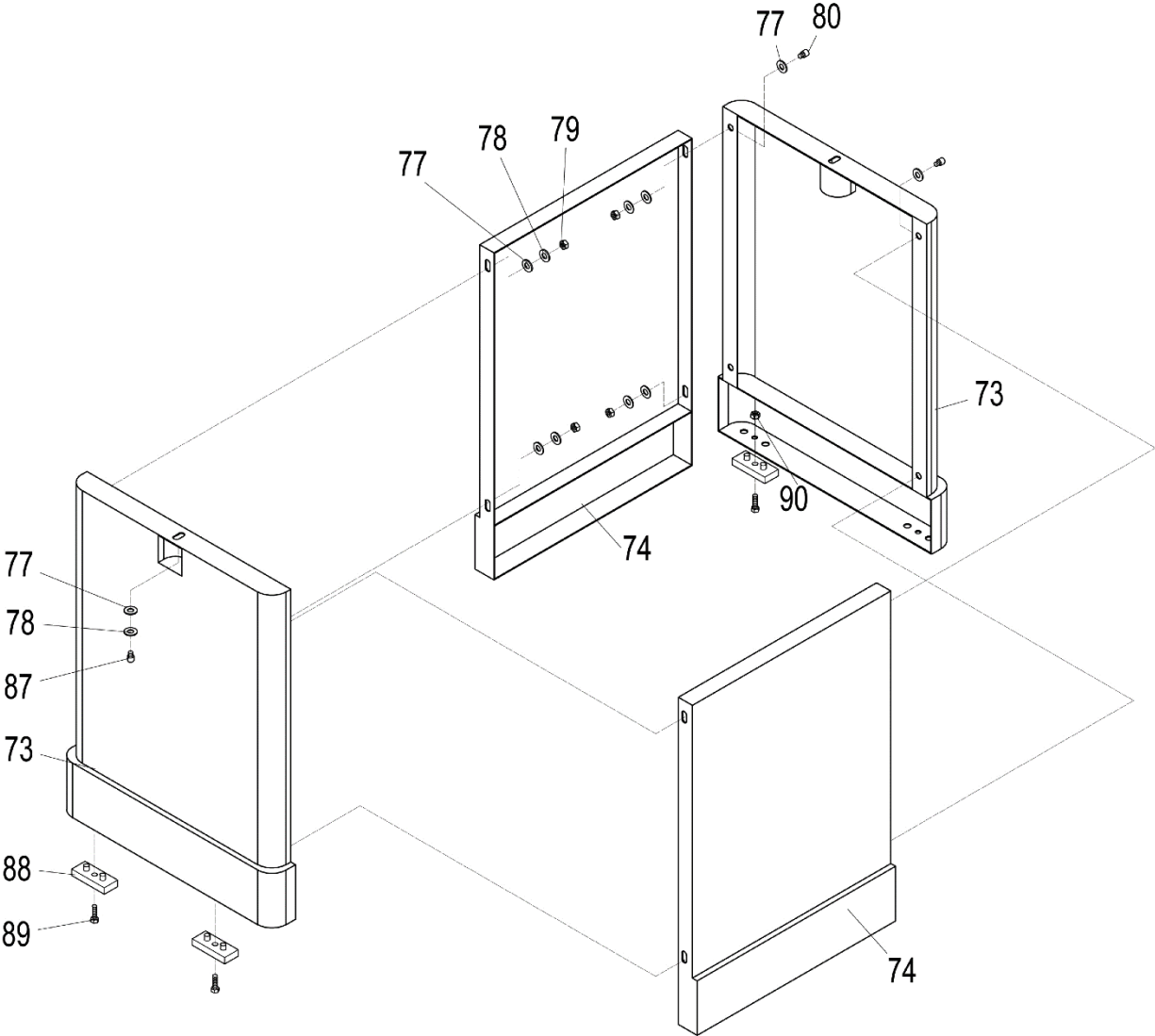

# Motor and Sander Assembly

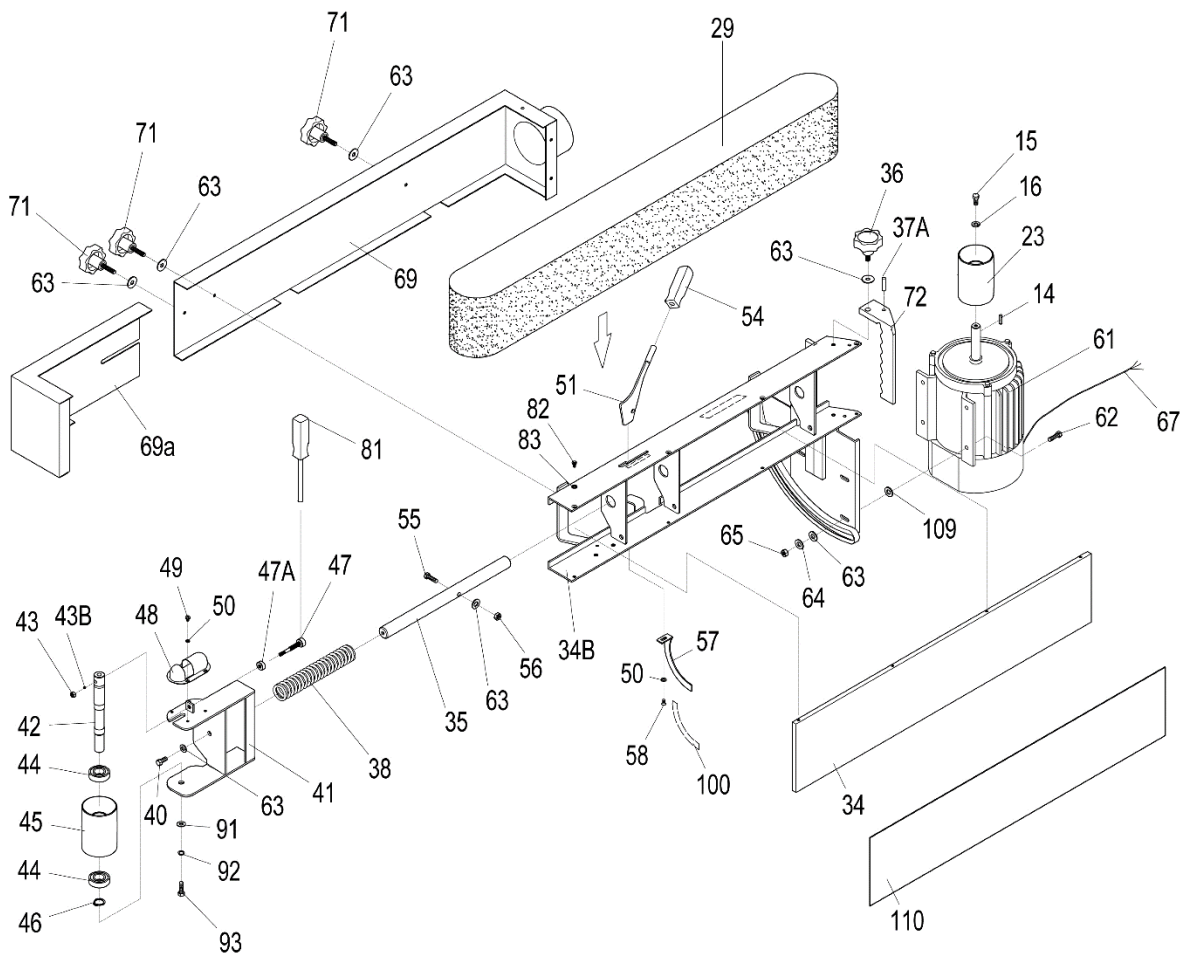

End Table

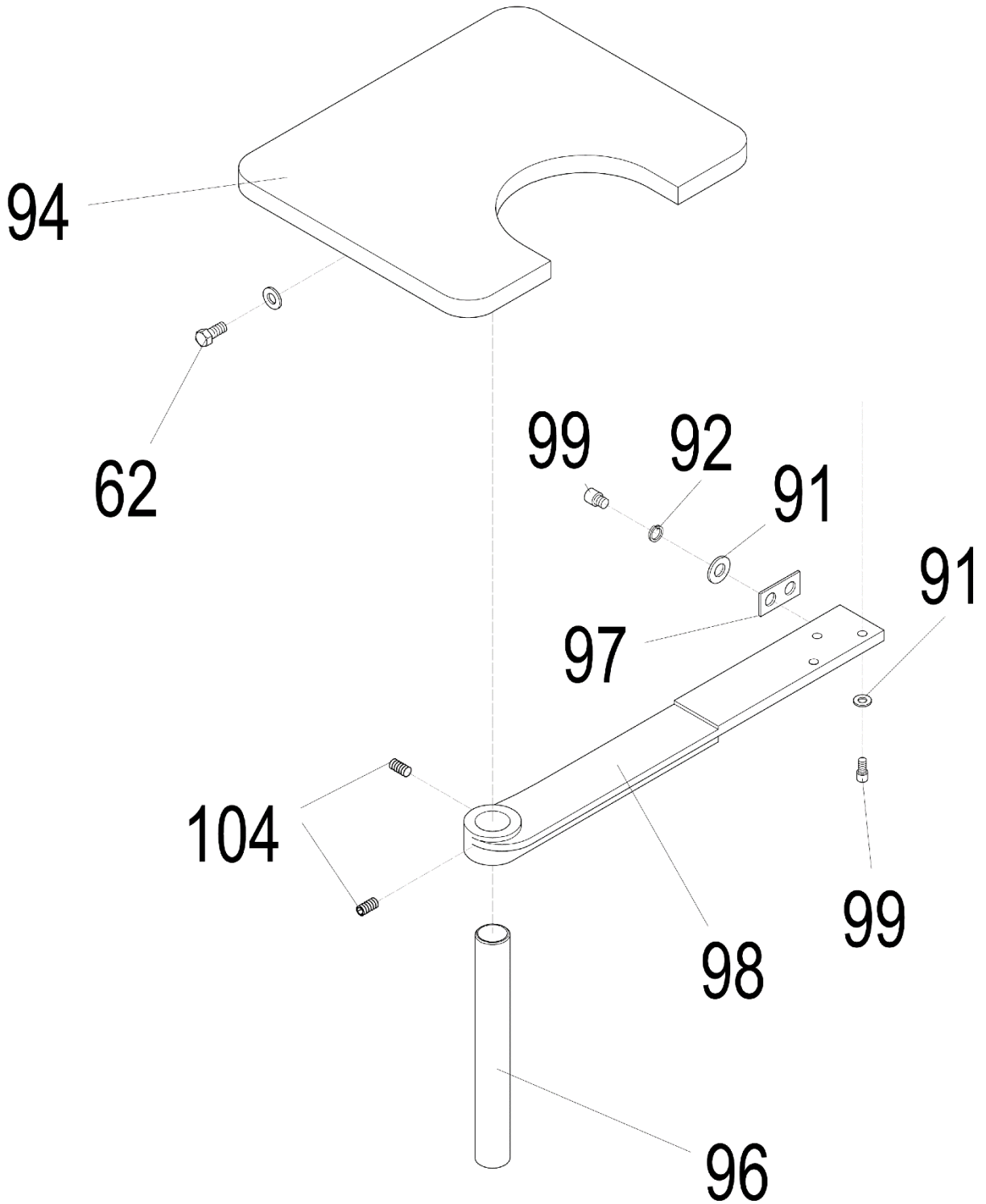

Index	Part Number	Descriptions	Specifications	QTY
<b>1</b>	20101001B	Base		1
<b>2</b>	W0000000	On-Off Switch		1
<b>3</b>	10105052N	Switch Box		1
<b>4</b>	S0030324	Pan Head Screw	3/16"-24UNC*1-1/2"	3
<b>6</b>	S0110300	Nut	3/16"-24UNC	5
<b>7</b>	S1017W-2	Strain Relief		2
<b>8</b>	20101005	Work Table Bracket		1
<b>9</b>	S0120380	Lock Nut	3/8"-24UNC	1
<b>10</b>	20101007	Cam Eccentric		1
<b>10A</b>	S0110600	Nut	3/8"-16UNC	1
<b>11</b>	S0310525	Pin		1
<b>12</b>	10102024	Lock Handle		1
<b>13</b>	10102023	Lock Knob		1
<b>14</b>	S0410525	Key		1
<b>15</b>	S0020416	Hex Head Screw	1/4"-20UNC*1"L	1
<b>16</b>	S0210404	Washer	1/4"	1
<b>17</b>	20101011A	Table		1
<b>17A</b>	S0020510	Hex Head Screw	5/6"-18UNC*5/8"L	4
<b>18</b>	20101065	Special Screw		2
<b>19</b>	S0111000M	Nut	M10*P1.5	2
<b>19A</b>	S0210600	Spring Washer	3/8"	2
<b>20</b>	20101013	Guide Block		2
<b>21</b>	20101014	Fence		1
<b>22</b>	20101015	Knob		3
<b>23</b>	20101016	Drive Drum		1
	6305 MGA	Miter Gauge Assembly		1
<b>24</b>	20102017	Guide Bar		1
<b>25</b>	S0310306	Roll Pin		1
<b>26</b>	S0050404	Set Screw	1/4"-20UNC*1/4"L	1
<b>27</b>	10104049	Locating Plate		1
<b>28</b>	10104050	Pointer		1
<b>28A</b>	20102020	Position Block		1
<b>29</b>		Sanding Belt	6" x 89" (Local Purchase)	1
<b>30</b>	10104046	Miter Gauge Body		1
<b>31</b>	S0030108	Round Head Screw	5/32"-32UNC*1/2"L	3
<b>32</b>	S0110100	Hex Nut	5/32"-32UNC	3
<b>33</b>	10104045	Knob		1
<b>34</b>	20101048	Sanding Platen		1
<b>34B</b>	20101049	Sanding Platen Stand		1
<b>35</b>	20103023	Tension Bar		1
<b>36</b>	20101039	Knob		1

Index	Part Number	Descriptions	Specifications	QTY
<b>37A</b>	S0310640	Roll Pin		1
<b>38</b>	20103025	Spring		1
<b>39</b>	20101055	Spacer		1
<b>40</b>	S0020510A	Hex Head Bolt	5/16"-18UNC*5/16"L	1
<b>41</b>	20103050A	Idler Drum Bracket		1
<b>42</b>	20103051	Roller Shaft		1
<b>43</b>	S0120200	Nylon Lock Nut	1/4"-20UNC	1
<b>43B</b>	20103029B	Steel Ball		1
<b>44</b>	C1106004	Ball Bearing	6004ZZ	2
<b>45</b>	20103028	Idler Drum		1
<b>46</b>	S0520017	Retaining Ring		1
<b>47</b>	20103029C	Tracking Adjusting Screw		1
<b>47A</b>	20103029A	Micro Adjusting Screw		1
<b>48</b>	20201013	Adjustment Cover		1
<b>49</b>	S0030304	Round Head Screw	3/16"-24UNC*1/4"	4
<b>50</b>	S0230300	Spring Washer	3/16"	6
<b>51</b>	20101031	Belt Tension Arm		1
<b>54</b>	20101032a	Belt Tension Handle		1
<b>55</b>	S0020530	Hex Head Screw	5/16"-18UNC*1 3/4"L	1
<b>56</b>	S0120201	Hex Nut	5/16"-18UNC	1
<b>57</b>	20101033	Tilt Pointer		1
<b>58</b>	S0030318	Round Head Screw		1
<b>59</b>	10102022	Pointer		1
<b>60</b>	S0030304	Round Head Screw		2
<b>61</b>	M000010	Motor	1.5HP 1Ph 115/230V	1
<b>62</b>	S0020520	Hex Head Bolt	5/16"-18UNC*1 1/4"L	4
<b>63</b>	S0210500C	Flat Washer	5/16"	21
<b>64</b>	S0230506	Spring Washer	5/16"	8
<b>65</b>	S0110500	Hex Nut	5/16"-18UNC	6
<b>67</b>	L000000M	Motor to Switch Cord		1
<b>68</b>	L0000000	Power Cord		1
<b>69</b>	20101038L	Belt Cover (Long)		1
<b>69A</b>	20101038S	Belt Cover (Short)		1
<b>70</b>	20101002	Table Plate		2
<b>71</b>	20101024	Knob	M8*20L	4
<b>72</b>	20101040	Stop Bracket		1
<b>73</b>	30300036	Stand Side		2
<b>74</b>	30300037	Stand Front/Back		2
<b>77</b>	S0210500	Flat Washer	5/16"	18
<b>78</b>	S0230506	Spring Washer	5/16"	10

Index	Part Number	Descriptions	Specifications	QTY
<b>79</b>	S0110500	Hex Nut	5/16"-18UNC	8
<b>80</b>	S0020510	Cap Head Bolt	5/16"-18UNC*5/8"L	10
<b>81</b>	20103044	Belt Tension Driver		1
<b>82</b>	S0040512M	Screw	M5*0.8P*12	8
<b>83</b>	S0220300	Wavy Washer		8
<b>87</b>	S0020520	Cap Head Bolt	5/16"-18UNC*1/4"L	2
<b>88</b>	10401029	Rubber Feet		4
<b>89</b>	S0090512	Round Head Screw	5/16"-18UNC*5/8"L	4
<b>90</b>	S0110500	Hex Nut	5/16"-18UNC	4
<b>91</b>	S0210403	Flat Washer	1/4"	3
<b>92</b>	S0230400	Spring Washer	1/4"	2
<b>93</b>	S0020616M	Hex Head Screw	M6*1.0P*16	1
<b>94</b>	20101051	End Table		1
<b>96</b>	20101050	Support Rod		1
<b>97</b>	40101016B	Mounting Bracket		1
<b>98</b>	20101052	Table Bracket		1
<b>99</b>	S0020410	Cap Head Screw	1/4"-20UNC*5/8"L	5
<b>100</b>	J0000102	Tilt Scale		1
<b>104</b>	S0050406	Set Screw	1/4"-20UNC*3/8"L	2
<b>110</b>	20101048A	Graphite Platen Pad		1

# Maintenance Record

Date	Task	Operator

# Notes

---

---

---

---

---

---

---

---

---

---

---

---

---

---

---

---

---

---

---

---

---

---

---

---

---

---

---



# Warranty and Service

Oliver Machinery makes every effort to assure that its equipment meets the highest possible standards of quality and durability. All products sold by Oliver Machinery are warranted to the original customer to be free from defects for a period of two (2) years on all parts excluding electronics and motors which are warranted for one (1) year from the date of shipment. Oliver Machinery's obligation under this warranty shall be exclusively limited to repairing or replacing products or parts or components, at its sole option, determined by Oliver Machinery to be defective. Oliver Machinery shall not be required to provide other form of indemnity or compensation including but not limited to compensatory damages.

This warranty does not apply to defects due to direct or indirect misuse, abuse, negligence, accidents, unauthorized repairs, alternation outside our facilities, lack of maintenance, acts of nature, or items that would normally be consumed or require replacement due to normal wear and tear.

## **OTHER TERMS**

To obtain and exercise the warranty right, please call 800-559-5065 or fill out warranty request form online at [www.olivermachinery.net](http://www.olivermachinery.net).

Warranty parts are shipped via Parcel or Ground. Additional charges will occur and charge to customers if express shipping is required.

## **DISCLAIMER**

Under no circumstances shall Oliver Machinery be liable for death, personal or property injury, or damages arising from the use of its products.

Oliver Machinery reserves the right to make changes without prior notice to its products to improve function or performance or design.

## **FOR MORE INFORMATION**

If you need assistance or have questions beyond what is covered in the scope of this warranty information, please call 800-559-5065 or email us at [info@olivermachinery.net](mailto:info@olivermachinery.net).







Oliver Machinery is always adding new Industrial Woodworking products to the line.

For complete, up-to-date product information, visit us online at:

[WWW.OLIVERMACHINERY.NET](http://WWW.OLIVERMACHINERY.NET)

or call toll free 1-800-559-5065

**\*\* SAVE THIS MANUAL FOR FUTURE REFERENCES. \*\***