

OLIVER

SEMI-OPTIMIZING CUT-OFF SAW

CE

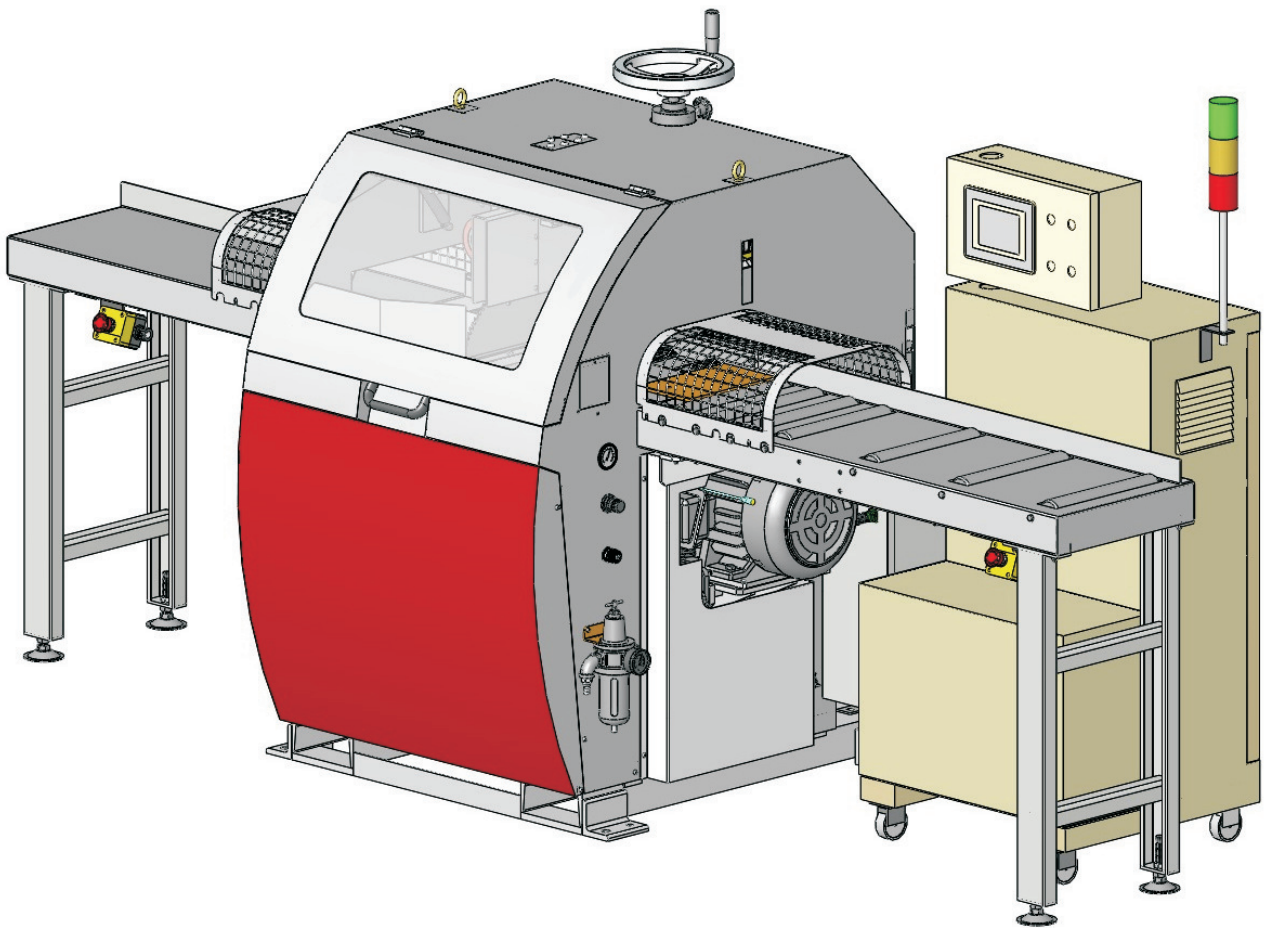

M-5045.002

OPERATION & BREAK-DOWN

SPECIFICATIONS

Model NO.:

Serial NO.:

Production date:

Operating volt: _____ Volt

Drive specifications:

Saw arbor motor	1 set	10 HP	V	Hz
Feed motor	1 set	2 KW	220 V	

Belt specifications:

Saw arbor	1 pc	ribbed belt	720-8M-40
Conveyor rollers(servo motor)	1 pc	ribbed belt	720-8M-40
Conveyor rollers	1 pc	ribbed belt	2400-8M-40

Basic parameters:

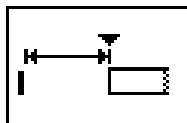

(refer to Ch.3-2)

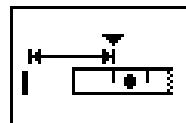

(refer to Ch.3-2)

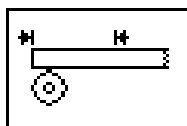

(refer to Ch.3-2)

PREFACE

This manual explains how to install, operate, and maintain the **SEMI-OPTIMIZING CUT-OFF SAW**. Please make certain to read the information contained herein to ensure safe operation and to achieve the longest life span and finest results possible.

When your saw requires professional repair or maintenance, contact your local dealer giving him the following information:

- Model number
- Serial number
- Date of purchase
- Precise details of the fault or problem

Your dealer can provide parts and service authorized by head office ensuring safe and efficient operation.

CONTENTS

CHAPTER1: INTRODUCTION	1
1-1 SAFETY PRECAUTIONS	1
1-2 SPECIFICATIONS	6
1-3 FEATURES	7
1-4 LOCATION OF PARTS.....	8
CHAPTER 2: INSTALLATION	12
2-1 PRE-INSTALLATION INSPECTION	12
2-2 MOVING THE MACHINE	12
2-3 POSITIONING THE MACHINE.....	13
2-4 CONNECT AIR SOURCE (COMPRESSED AIR)	14
2-5 POWER CONNECTION.....	15
2-6 CHECK THE SAFETY GUARD DEVICES AND STARTING TEST.....	16
2-7 CONNECT DUST COLLECTION EQUIPMENT	27
CHAPTER 3: OPERATION	28
3-1 INSTALL AND REMOVE SAW BLADE.....	28
3-2 SETTING BASIC PARAMETERS.....	30
3-3 SELECT THE CUTTING MODE	50
3-4 ADJUST THE AIR PRESSURE OF PRESSURE ROLLER.....	70
3-5 ADJUST HEIGHT OF PRESSURE ROLLERS	71
3-6 START THE MACHINE	72
3-7 ADJUST FEED SPEED.....	72
3-8 FEED THE WORKPIECE	73
3-9 ADJUST SAWBLADE CUTTING SPEED	74
3-10 MARK THE CRAYON LINE.....	74
CHAPTER 4: MAINTENANCE	75
4-1 CLEANING AND LUBRICATING.....	75
4-2 REPLACE THE CENTER PLATE FOR SAWBLADE	77
4-3 FILTER/REGULATOR.....	78
4-4 ADJUST PROXIMITY SWITCHES FOR SAW ARBOR ELEVATION CONTROL.....	79
4-5 REPLACE THE TIMING BELT OF SAW ARBOR	80
4-6 REPLACE THE TRANSMISSION TIMING BELT	81
4-7 DRAIN WATER FROM THE PRESSURE AIR RESERVIOR	82
4-8 TROUBLE SHOOTING	83
APPENDIX: AIR CIRCUIT DIAGRAM	91

CHAPTER 1: INTRODUCTION

1-1 SAFETY PRECAUTIONS

1-1.1 GENERAL INFORMATION

This instruction manual is used for the safe operation and maintenance of the Cut-off Saw.

Always keep this manual available at the place of machine operation.

Ensure that work on and with the machine is only carried out by reliable personnel who have the relevant training, are authorized, and have been certified for this type of work. Personnel should be familiar with the local conditions or by instructed persons under the direction and supervision of a manager. This applies not only to operation of the machine, but also to special work within the scope of its use (Commissioning, Maintenance, etc.) and particularly for work on hydraulics, pneumatics, electrics and software.

Do not modify electrical circuits, electrical components, parts or anything on the machine unless authorized by the manufacturer. The manufacturer will not accept any liability for personal injury or material damage, arising on account of the following actions:

- Non-observant of operating instructions.
- Non-observant of the details on the order confirmation.
- Non-observant of general and country-specific valid conditions and regulations.

All of the figures and diagrams in this instruction manual provide the most up-to-date information applicable to this machine. Upon receipt of the Cut-off saw, customers are required to make sure the model number on the cover of the instruction manual is the same as the machine purchased. As long as all of the conditions are being met for proper usage and maintenance (and assuming that it is operated under normal working conditions) a one (1) year warranty will take affect. If the damage of the machine is due to improper usage, maintenance, or any unforeseen catastrophic, natural disaster, the warranty does not apply.

1-1.2 GENERAL SAFETY REGULATIONS

- ☑ This machine is intended exclusively for wood cutting. Unauthorized materials, i.e. metal are not to be used. Any other use than that designated will be construed as improper.
- ☑ Machine operators are to be only qualified personnel who have been adequately trained.
- ☑ Personnel must be trained in all areas of safety regulations and requirements.
- ☑ Operators are to familiarize themselves with all areas of the operation manual carefully before operating machine. It is important to pay attention to the directions on the labels attached to the machine.
- ☑ During installation, properly ground the machine to prevent electric shock hazards.
- ☑ All guards and covers shall be closed at all times except when maintenance is required.
- ☑ Inspect machine only when it is turned off.
- ☑ Do not attempt to clear the chips from work piece before actuating spindle motor. Let the saw blade run idle for at least five (5) minutes.
- ☑ Disconnect electrical power before installing saw blade or performing routine maintenance.
- ☑ Wear goggles, mouthpiece, ear protection and safety shoes when operating machine.
- ☑ Do not wear loose clothing, long sleeves or neckties during operation.
- ☑ Wear protective hair covering or hard hat to prevent long hair from falling down during operation.
- ☑ Keep the area around machine clean and dry. Remove clogs and scraps.
- ☑ Test machine operation manually before operating in automatic mode.
- ☑ Never operate the machine unattended; when switching off, remain at the machine until all motion stops.
- ☑ Do not change feed speed while machine is running. During cutting, clear all unnecessary objects other than work piece on the machine or table.
- ☑ After switching off the spindle motor, allow the spindle to stop freely. Never attempt to stop the spindle by hand or other objects.
- ☑ During cutting, do not try to adjust the dust hood or pressure mechanism roll after spindle starts. The dust collector is to be switched on before commencing machining.
- ☑ Never modify mechanical functions and capacity of machine without being approved.
- ☑ Only a qualified operator should be allowed to operate the machine.
- ☑ Never open the electrical cabinet without approval. Consult an electrical technician or qualified electrical engineer for trouble shooting.
- ☑ This machine cannot be used in a spark generated or explosive environment.

1-1.3 GENERAL SAFE WORKING PRACTICES

The information given in this annex should be included in the instruction handbook. The manufacturer should also include any other information specific to the machine, which concerns its safe use.





- ☑ Only persons who are properly trained shall operate the machine. The training shall include information concerning the dangers associated with the use of the machine and the precautions to be observed. An unobstructed working area around the machine is fundamental to its safe operation. The floor shall be level, well maintained and kept free from loose materials, i.e. chips and shavings.
- ☑ Adequate general or localized lighting of the work place shall be provided.
- ☑ Personnel protective devices, i.e. ear protection shall be used whenever necessary when the machine is in use. Gloves shall be used when handling tools or rough materials. The operator shall not leave the machine running while unattended.
- ☑ Any defects or faults in the machine including guards or tools shall be reported as soon as they are discovered and appropriate action taken.
- ☑ Procedures for safe cleaning, maintenance, fault finding and correction shall be used.
- ☑ Only tools which comply with EN 847-1 shall be used.
- ☑ Tool manufacturer's instructions for use, adjustment and repair of tools shall be followed.
- ☑ The maximum rotation speed marked on the tools must not be exceeded.
- ☑ It is important to ensure that any spacing collars used are suitable for the purpose and as stated by the manufacturer.
- ☑ The work piece shall be properly supported using additional support if necessary, i.e. for longer lengths. To ensure work pieces are effectively retained it is important to maintain a common batch stock size.
- ☑ No attempt shall be made to remove any splinters or other part of the work piece from the cutting area while the machine is running.
- ☑ Machine shall not be used unless all of the guards and other safety devices necessary for the machining are in position, are in good working order and are properly maintained.
- ☑ Operators shall be trained and instructed in the proper use of the guards. In addition, they shall be instructed to carry out regular examination of such guards and safety devices.
- ☑ Ground the machine. It should make sure the "PE" terminal being connection before machine operating and disconnect the electrical power before any electrical service against electrical shock due to indirect contact.
- ☑ Don't use machines in damp or wet locations, or expose them to rain. Please provide a suitable illumination around the machine for safety operation.

- ☑ It is necessary to wait for the complete standstill of the machine before opening the guard(s).
- ☑ SHUT OFF the powers, removed the products, and isolated energy before leaving the machine. Shut off the power and lockout only when the machine is stationary before inspection, maintenance, adjustment and cleaning.

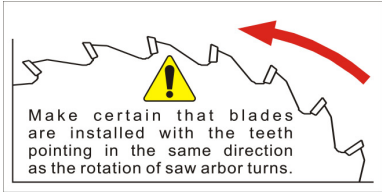

- ☑ If a blockage is likely to occur, please the EMS button to stop the machine, the use special-key to release the safety guard and use tools to help remove the blockage wood by step.
- ☑ The floor area around the machine to be level, well maintained and free from loose material e.g. chips and off-cuts.
- ☑ Adequate general or localized lighting to be provided.
- ☑ Stock and finished workpieces to be located close to the operator normal working position.
- ☑ Please wear hearing protection to reduce the risk of induced hearing loss.
- ☑ Please wear respiratory protection to reduce the risk of inhalation of harmful dust.
- ☑ Please wear gloves for handling saw blades.
- ☑ To stop the machine running whilst unattended.
- ☑ To report faults in the machine, including guards or saw blades, as soon as they are discovered.
- ☑ To adopt safe procedures for clearing, maintenance and remove chips and dust regularly to avoid the risk of fire.
- ☑ To follow manufacturers instructions for use, adjustment and repair of saw blades.
- ☑ To observe the maximum speed marked on the saw blades.
- ☑ To use correctly sharpened saw blades follow manufacturers required process.
- ☑ To ensure that any spacers and spindle rings used are suitable for the purpose as stated by the manufacturer.
- ☑ To refrain from removing any off-cut or other part of the workpiece from the cutting area until the saw blade has stopped.
- ☑ To ensure that guards and other safety devices necessary for machine operation are in position, in good working order and properly maintained.
- ☑ The training of the operator should be carried out by our authorized agent or service engineer in an oral/practical in site of the ordered sawing machine, including explanation of protective device, mechanism, adjustment and operation/use.

1-1.4 CONTESTS OF WARNING LABELS

Dangerous area and Working Environment		
Hazards Location	Precaution	Marking Label
Working area	High noise! High dust environment! Be careful for eject-out of material! Please wear gloves during operation.	
Warning sign	Warning on the electrical cabinet and terminal box. Be sure to connect the earth line on control box, electric cabinet.	
Sawing area	Rotating saw-blade! Do not open guard before the movements are stopped standstill.	
Working area	High speed! Don't put fingers, hands or any part of body into sawing area before the saw-blade stop standstill. Shut down the machine before inspection, maintenance, adjustment and cleaning.	
Driving area	Do not access the driving belt during machine operation. Shut down the machine before inspection, maintenance, adjustment and cleaning. Keep safety guard in place.	
Outfeed area	Impact hazard. Do not stand outfeed area during operation.	

*Operator MUST follows all safety principles and warning stickers on machine.

1-2 SPECIFICATIONS

Saw motor	10HP
Feed motor	2 kw
Saw spindle speed	3400 r.p.m
Feed speed	80 m/min
Circular saw diameter	Ø455mm (18")
Saw spindle diameter	Ø30mm
Height of bed [H]	900mm
Minimum distance of marks	20mm
Minimum cutting size (L×W×H)	300×30×10mm
Mini. cutting length (for cutting the last piece of product)	150mm(200mm)
Cutting size	See the diagram of cutting range
Max. loading weight of material	25kg
Cutting tolerance (for material length up to 1m)	±1mm
Cutting tolerance (for material length up to 2m)	±2mm
Air pressure	7-9 kg/cm ²
Dust outlet	Ø100mm x 2
Machine weight	900kgs
Machine dimension(L×W×H)	1170×1210×1200mm (W/O roller table)

*We reserve the right to amend any of the above specifications without prior notice.

CUTTIG RANGE DIAGRAM:

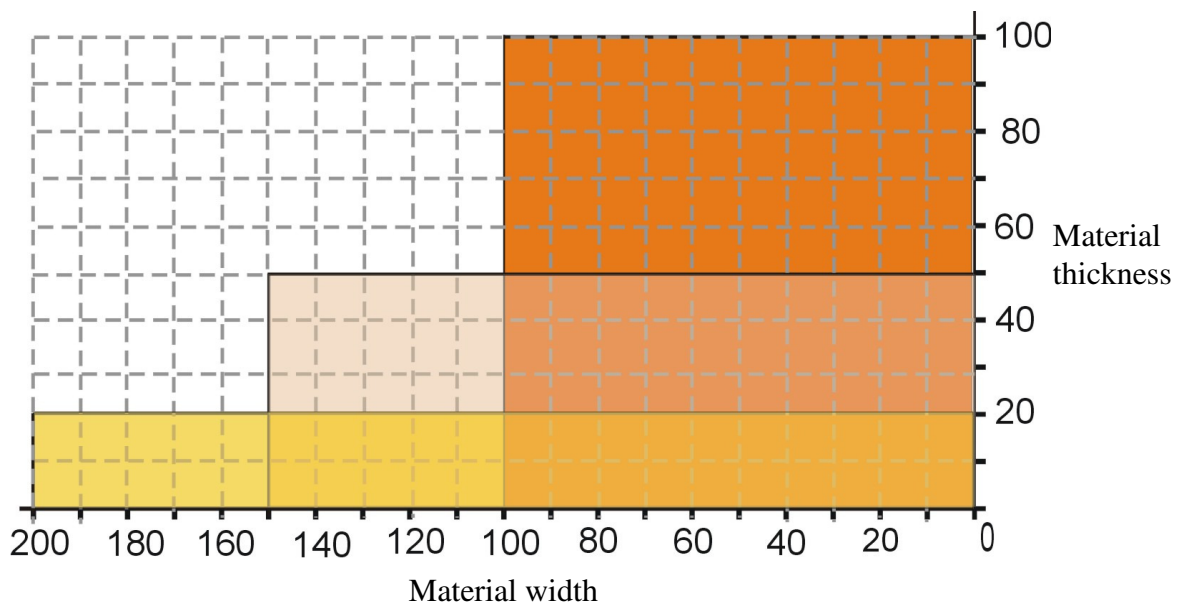

1-3 FEATURES

This economically priced, compact, easy to operate saw provides extremely high cutting accuracy at high feed speeds up to 80 meters per minute.

- High cutting accuracy within ± 1 mm.
- Comprehensive safety guards reduce noise and minimize danger.
- Employs servo motor and driver which feature compact construction, high speed response capability, high torque and comprehensive protection features.
- The machine employs fluorescent crayons to indicate the defective parts. And then a photoelectric sensor will sense the crayon lines and guide the blade to cut off the defective parts.

1-4 LOCATION OF PARTS

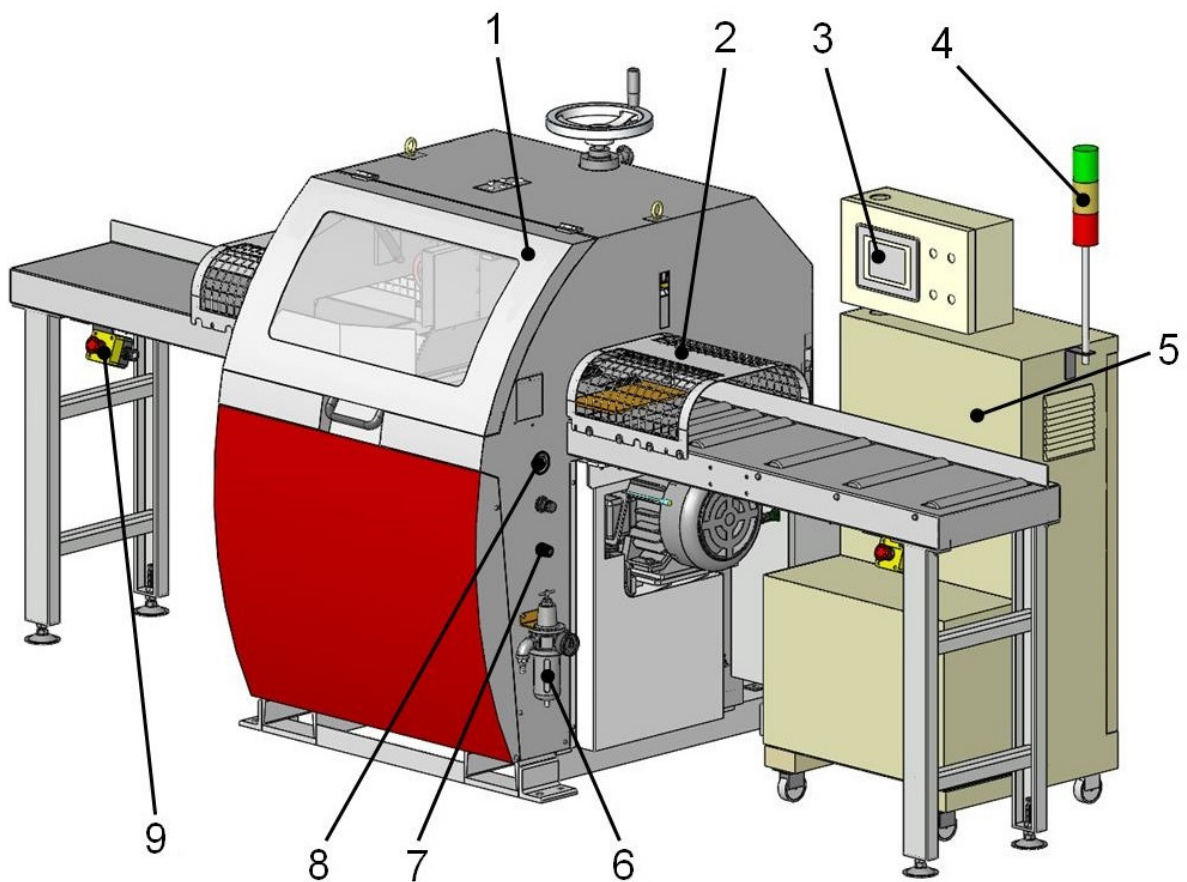

1. Safety door
2. Infeed screen safeguard
3. Control panel
4. Warning lamp
5. Electrical control box
6. Filter/regulator unit
7. Cutting speed regulator
8. Air pressure gauge for pressure rollers
9. Emergency stop switch

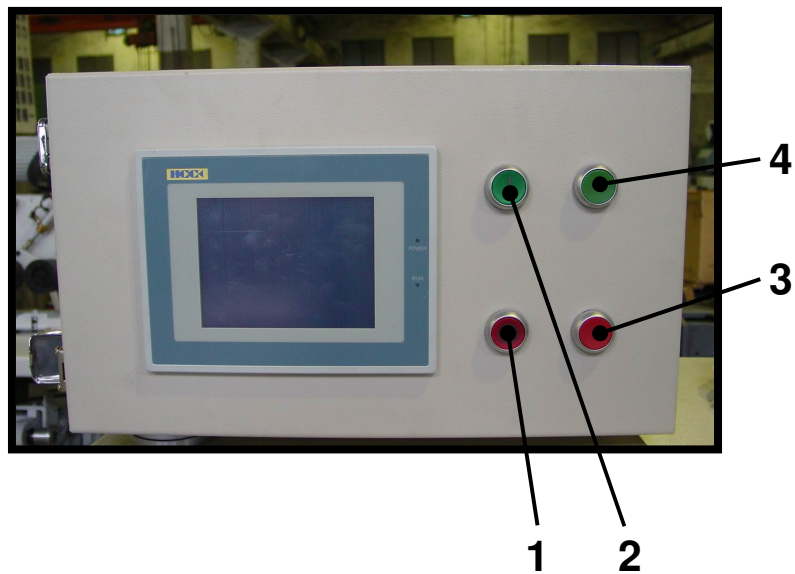
CONTROL PANEL:

1. Power OFF switch – button (red)
2. Power ON switch – button (green)
3. Stop button (red) – for terminal
4. Start button (green) – for terminal

LCD SCREEN:

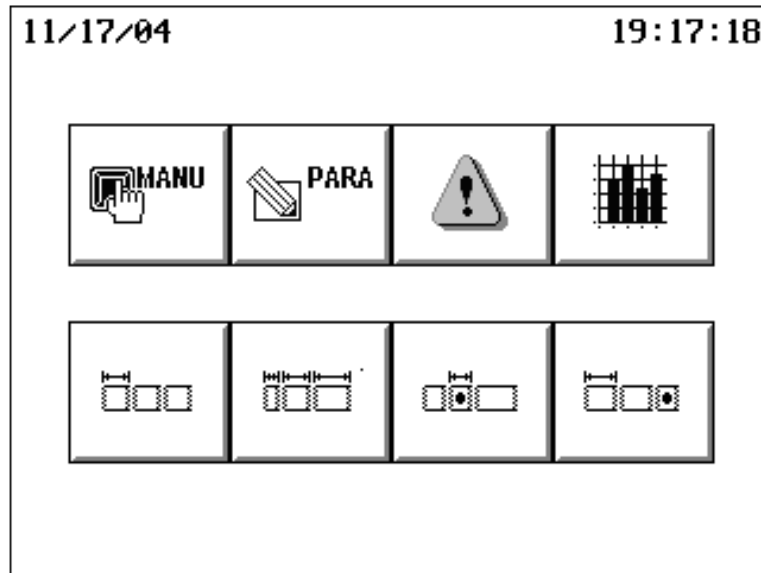

All functions can be selected on this page:



Manual test function



Setting parameter



Checkup window

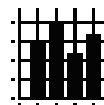

Statistics



Fix length cutting mode

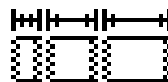

Sequential cutting mode

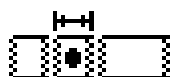

Mark Line cutting mode



Mixed cutting mode
(Fix + Mark)

MACHINE DIMENSIONS:

