



4640 and 4665 Bandsaw 20" and 24"

Owner's Manual



Oliver Machinery
Seattle, WA
info@olivermachinery.net

M-4640 9/2003
© Copyright 2003
www.olivermachinery.net

Warranty

Oliver makes every effort possible to assure that its equipment meets the highest possible standards of quality and durability. All products sold by Oliver are warranted to the original customer to be free from defects for a period of 2 (two) years on all parts, excluding electronics and motors, which are warranted for 1 year. Oliver's obligation under this warranty shall be exclusively limited to repairing or replacing (at Oliver's option) products which are determined by Oliver to be defective upon delivery F.O.B. (return freight paid by customer) to Oliver, and on inspection by Oliver. This warranty does not apply to defects due, directly or indirectly, to misuse, abuse, negligence, accidents, unauthorized repairs, alterations, lack of maintenance, acts of nature, or items that would normally be consumed or require replacement due to normal wear. In no event shall Oliver be liable for death, personal or property injury, or damages arising from the use of its products.

Warning

Read this manual thoroughly before operating the machine. Oliver Machinery disclaims any liability for machines that have been altered or abused. Oliver Machinery reserves the right to effect at any time, without prior notice, those alterations to parts, fittings, and accessory equipment which they may deem necessary for any reason whatsoever.

For More Information

Oliver Machinery is always adding new Industrial Woodworking products to the line. For complete, up-to-date product information, check with your local Oliver Machinery distributor, or visit www.olivermachinery.net

WARNING

Read this manual completely and observe all warning labels on the machine. Oliver Machinery has made every attempt to provide a safe, reliable, easy-to-use piece of machinery. Safety, however, is ultimately the responsibility of the individual machine operator. As with any piece of machinery, the operator must exercise caution, patience, and common sense to safely run the machine. Before operating this product, become familiar with the safety rules in the following sections.

- **Always keep guards in place and in proper operating condition.**
 - **Keep hands out of line with the saw blade.**
 - **Use a push stick.**
1. **If you are not properly trained** in the use of a bandsaw do not use until the proper training has been obtained.
 2. **Read, understand and follow** the safety instructions found in this manual. Know the limitations and hazards associated with this machine.
 3. **Electrical grounding:** Make certain that the machine frame is electrically grounded and that a ground lead is included in the incoming electrical service. In cases where a cord and plug are used, make certain that the grounding plug connects to a suitable ground. Follow the grounding procedure indicated in the National Electrical Code.
 4. **Eye safety:** Wear an approved safety shield, goggles, or glasses to protect eyes. Common eyeglasses are only impact-resistant, they are not safety glasses.
 5. **Personal protection:** Before operating the machine, remove tie, rings, watch and other jewelry and roll up sleeves above the elbows. Remove all loose outer clothing and confine long hair. Protective type footwear should be used. Where the noise exceeds the level of exposure allowed in Section 1910.95 of the OSHA Regulations, use hearing protective devices. Do not wear gloves.
 6. **Guards:** Keep the machine guards in place for every operation for which they can be used. If any guards are removed for maintenance, DO NOT OPERATE the machine until the guards are reinstalled.
 7. **Work area:** Keep the floor around the machine clean and free of scrap material, saw dust, oil and other liquids to minimize the danger of tripping or slipping. Be sure the table is free of all scrap, foreign material and tools before starting to use the machine. Make certain the work area is well lighted and that a proper exhaust system is used to minimize dust. Use anti-skid floor strips on the floor area where the operator normally stands and mark off machine work area. Provide adequate work space around the machine.
 8. **Material condition:** Do not attempt to saw boards with loose knots or with nails or other foreign material. Do not attempt to saw twisted, warped, bowed stock.
 9. **Operator position:** Maintain a balanced stance and keep your body under control at all times.
 10. **Before starting:** Before turning on machine, remove all extra equipment such as keys, wrenches, scraps, and cleaning rags away from the machine.
 11. **Careless acts:** Give the work you are doing your undivided attention. Looking around, carrying on a conversation, and "horseplay" are careless acts that can result in serious injury.

12. **Disconnect all power sources:** Before performing any service, maintenance, adjustments or when changing blades. A machine under repair should be RED TAGGED to show it should not be used until the maintenance is complete.
13. **Job completion:** If the operator leaves the machine area for any reason, the bandsaw should be turned "off" and the blade should come to a complete stop before their departure.
14. **Replacement parts:** Use only genuine Oliver Machinery factory authorized replacement parts and accessories; otherwise the warranty and guarantee is null and void.
15. **Misuse:** Do not use this Oliver bandsaw for other than its intended use. If used for other purposes, Oliver disclaims any real or implied warranty and holds itself harmless for any injury or damage which may result from that use.
16. **Drugs, alcohol and medication:** Do not operate this machine while under the influence of drugs, alcohol, or any medication.
17. **This machine is designed** for cutting wood products only. Do not use to cut any kind of metal or substance other than wood.
18. **Never start the saw** while a workpiece is in contact with the blade.
19. **Make sure** the blade is running in the proper direction. The teeth should be pointing down at the point the blade enters the table viewing from the front of the saw.
20. **Health hazards:** Some dust created by power sanding, sawing, grinding, drilling and other construction activities contains chemicals known to cause cancer, birth defects or other reproductive harm. Some examples of these chemicals are:
 - Lead from lead-based paint.
 - Crystalline silica from bricks and cement and other masonry products.
 - Arsenic and chromium from chemically-treated lumber.Your risk from these exposures varies, depending on how often you do this type of work. To reduce your exposure to these chemicals, work in a well-ventilated area, and work with approved safety equipment, such as those dust masks that are specifically designed to filter out microscopic particles.

Familiarize yourself with the following safety notices used in this manual:

CAUTION: (This means that if precautions are not heeded, it may result in minor or moderate injury and/or possible machine damage)

WARNING: (This means that if precautions are not heeded, it could result in serious injury or possibly even death).

Table of Contents	Page Number
Warranty.....	2
Warnings.....	3-4
Table of Contents.....	5
Specifications.....	5
Contents of the Shipping Containers.....	6
Uncrating the Machine.....	6
Machine Preparation and Setup.....	6
Table Assembly.....	7
Dust Chute Assembly.....	7
Installing Blade.....	8
Tensioning Blade.....	8
Blade Tracking.....	9
Adjusting Upper Blade Guides.....	9
Adjusting Lower Blade Guides.....	10
Squaring Table to the Blade.....	10
Fence and Rail Adjustment.....	11
Electrical Connections.....	11-12
Miter Gauge.....	12
Dust Collection.....	12
Brake Pedal.....	12
Tilting the Table.....	12
Removing Blades.....	13
Replacing V-Belt.....	13
Adjusting Belt Tension.....	13
Maintenance.....	14
Lubrication.....	14
Troubleshooting.....	15

Specifications

Model No.....	4640.....	4655
Stock No.....	4640.001 (3HP, 1Ph).....	4655.001 (5HP, 1Ph)
	4640.002 (5HP, 3Ph).....	4655.002 (7.5HP, 3Ph)
Blade Speed (SFPM).....	4,000.....	5,000
Wheel Diameter (in.).....	20.....	24
Table Dim. (WxL/in.).....	26-3/4 x 20-1/2.....	31-1/2 x 23-3/4
Throat Distance (in.).....	19.....	23
Max. Stock Height (in.).....	11-1/4.....	13-3/4
Blade Length (in.).....	157.....	176
Blade width Cap. (in.).....	1/4 to 1-1/4.....	1/4 to 2
Table Height at 90° (in.).....	33-3/4.....	34-1/2
Table Tilt Limits.....	0° to 45°.....	0° to 45°
Motor.....	3HP, 1Ph.....	5HP, 1Ph
	220V Only	220V Only
	5HP, 3Ph, 220V/440V.....	7.5HP, 3Ph, 220V/440V
	Prewired 220V	Prewired 220V
Gross Weight (lbs.).....	750.....	900

Contents of the Shipping Containers

Oliver 4640 – 20” Bandsaw

1. 20” Bandsaw
1. Miter Gauge
1. Table and Rail Assembly
1. Fence
1. Dust Chute

Oliver 4655 – 24” Bandsaw

1. 24” Bandsaw
1. Miter Gauge
1. Table and Rail Assembly
1. Fence
1. Dust Chute

Uncrating the Machine

For protection against shifting during transport, the base of bandsaw was bolted to the shipping crate in two places. Remove these carriage bolts. Carefully uncrate the machine and remove the plastic bag. Be careful not to allow the table to fall to the ground during unpacking. Inspect the unit for signs of shipping damage. If damage is found, contact your dealer immediately. Retain all packaging materials in case it becomes necessary to ship the machine back to the dealer or to another site.

Machine Preparation and Setup

!WARNING

The equipment used to lift this machine must have a rated capacity at, or above the weight of the bandsaw. Failure to comply may cause serious injury!

The bandsaw must be positioned on a smooth, level surface. The area must be well lit and have plenty of room to maneuver with large pieces of wood.

Level the saw front to back and side to side using a level placed on the table. Use shims under the corners, if necessary, but make sure the saw is stable before being placed into service.

Clean all rust protected surfaces with a commercial solvent. Do not use acetone, gasoline, lacquer thinner or any type of flammable solvent, or a cleaner that may damage paint. Cover cleaned surfaces with WD-40 or a 20W machine oil.

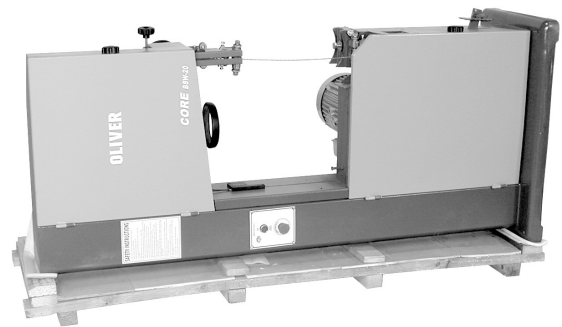

Table Assembly

CAUTION!

The table is heavy. Use the help of another person to lift and position the table.

1. Disconnect machine from power source.
2. Grease the trunnions (A, Figure 1) on bandsaw prior to assembling table.
3. Installing the table (B, Figure 2) is easiest if the blade is out of the way. The blade tension is loose as sent from the factory. Open upper and lower doors completely and remove the blade. Wear leather work gloves to protect your hands.
4. Remove the table mounting bolt and washer from the bandsaw trunnion.
5. Lift the table and carefully align the trunnions. Make certain the fence rail (C, Figure 2) is positioned at the front side of the bandsaw.
6. Make sure the trunnions are lined up properly (D, Figure 3) and secure the table by threading the bolt (E, Figure 3) into the threaded hole in frame trunnion.

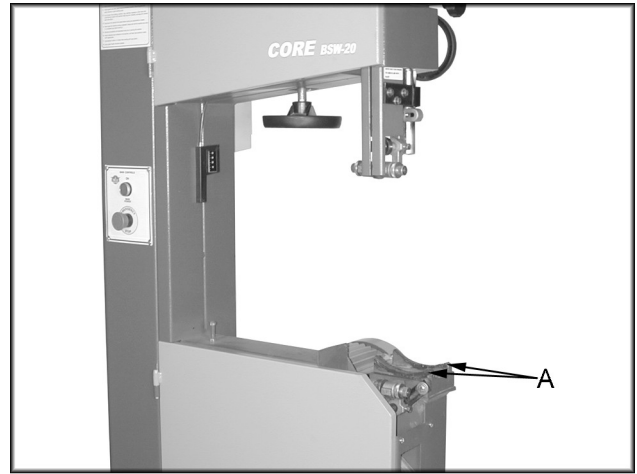

Figure 1

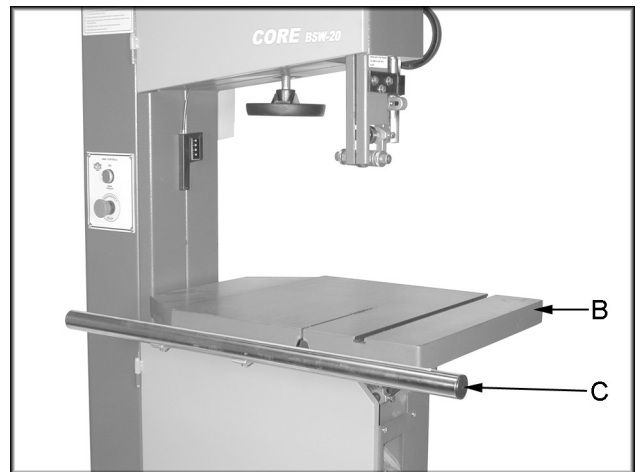

Figure 2

Dust Chute Assembly

Mount dust chute (G, Figure 3) with the provided screws (F, Figure 3) to the bandsaw frame.

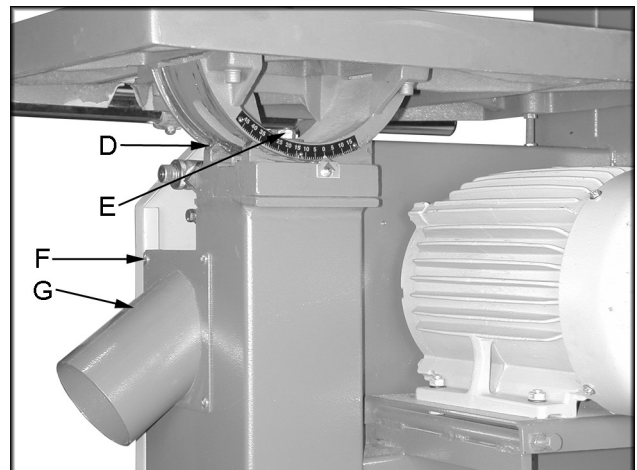

Figure 3

Installing Blade

!WARNING

Bandsaw blades are sharp so be very careful while handling. Failure to comply may cause serious injury!

1. **Disconnect machine from power source.**
2. Open upper and lower doors (A, Figure 4).
3. Put on leather gloves to protect your hands from the sharp teeth of blade.
4. Slide blade through table slot, ensuring that the teeth are pointing down toward the table.
5. Center the blade (B, Figure 4) on both the upper and lower wheels. Carefully thread the blade through the upper and lower blade guides as shown in Figure 4. **Note:** It may help to move the upper wheel down. This can be accomplished by rotating the handwheel (C, Figure 4).

Tensioning Blade

Proper blade tension is essential to any cutting operation on a bandsaw. Too little, or too much blade tension can cause blade breakage and/or poor cutting performance. Tension will vary depending on the blade being used and the type of material being cut.

1. **Disconnect machine from power source.**
2. At this point the blade should be properly positioned, but slack. Increase tension on the blade by rotating tensioning handwheel (C, Figure 4).
3. Move the upper guide assembly (D, Figure 4) and lower guide assembly (E, Figure 4) if they interfere with the blade during tensioning.
4. A reference gauge (F, Figure 4) indicates the approximate tension setting. **Note:** After setting tension and achieving the desired results make a note of what the tension gauge reads for the particular blade. This will help you get back to the desired tension if the particular blade has been removed or tension released. Keep in mind that blades will last longer if you release tension when not in use. Also, new blades will often stretch with use, and not all blades will be exactly the same length. Use blade

tension gauge as a guide for individual blades.

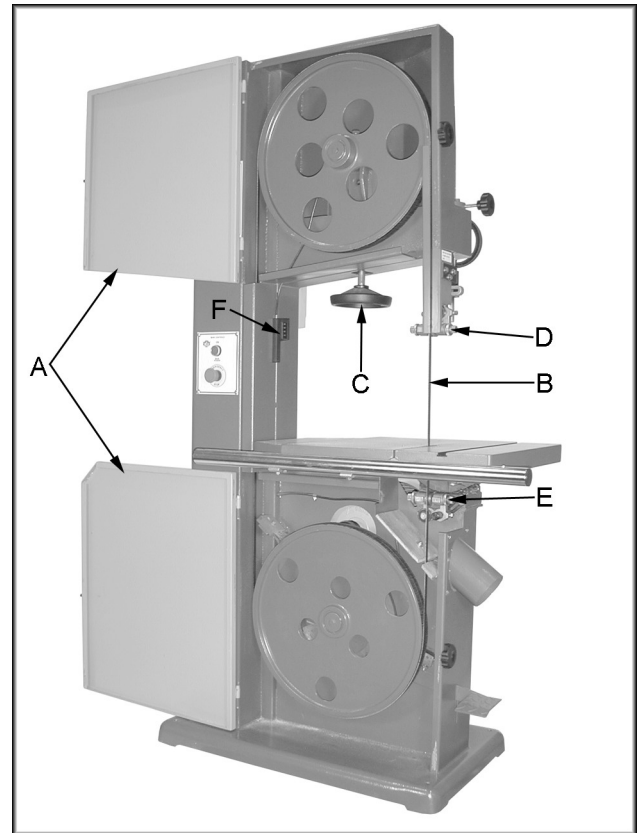

Figure 4

Blade Tracking

Blade tracking has been adjusted at the factory and shouldn't need any adjustment. If you are experiencing a problem follow the below listed steps.

1. **Disconnect machine from power source.**
2. Blade must be properly tensioned before adjusting blade tracking, see "Tensioning Blade" page 8. Move the upper guide assembly and lower guide assembly if they interfere with the blade.
3. Open upper wheel door and rotate the wheel forward by hand. Observe position of the blade on the wheel. The blade should rest in approximately the center of the wheel.
4. If adjustment is necessary, loosen the hex nut (A, Figure 5).
5. Adjust tracking by turning the knob (B, Figure 5) in 1/4 turn increments. Rotate wheel forward, and observe the position of blade on the wheel. Rotating the knob counter-clockwise will move the blade towards the front of the wheel. Rotating the knob clockwise will move the blade towards the back of the wheel.
6. Continue with adjustments until the blade is tracking properly.
7. Tighten the hex nut (A, Figure 5) while holding knob (B, Figure 5).

Adjusting Upper Blade Guides

The blade guard has been removed in Figure 6 for photo purposes only.

1. **Disconnect machine from power source.**
2. Blade tension and tracking must be properly adjusted prior to blade guide setup, see "Tensioning Blade" page 8 and "Blade Tracking" page 9.
3. Loosen bolt (C, Figure 6) and position the blade guide assembly so that the guides rest just behind the gullet of the blade teeth (D, Figure 6). Tighten the bolt.
4. Loosen the knurled jam nuts (E, Figure 6) that lock the guides (F, Figure 6) in place.

5. Turn the knurled knob (G, Figure 6) so that the guides rest lightly against the blade, approximately 0.003" away from the side of the blade, about the thickness of a piece of paper. **Do not** force the guides against the side of the blade. Tighten knurled jam nuts while holding the knurled knobs.
6. Adjust the blade support bearing so that it is 0.003" away from the back of the blade, about the thickness of a piece of paper. To make this adjustment loosen bolt (H, Figure 6) and slide the bearing and bearing post into position. Tighten the bolt.

Note: For best results the upper blade guide should be lowered so that it is just above the workpiece while cutting.

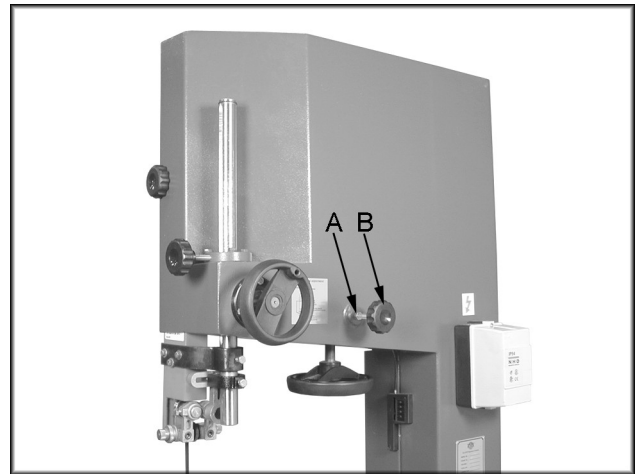

Figure 5

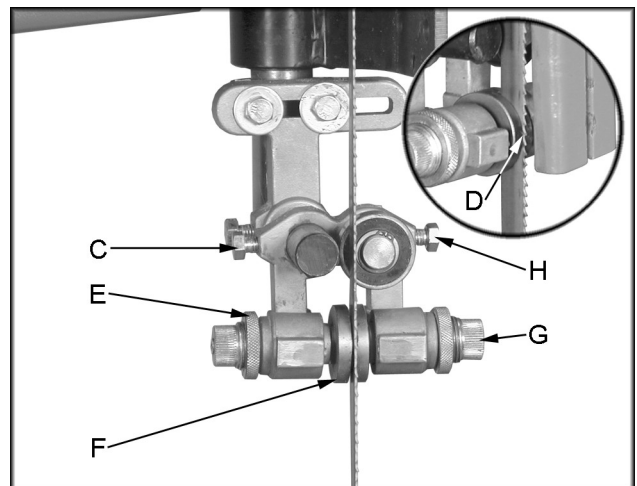

Figure 6

Adjusting Lower Blade Guides

1. Disconnect machine from power source.
2. Blade tension and tracking must be properly adjusted prior to blade guide setup, see "Tensioning Blade" page 8 and "Blade Tracking" page 9.
3. Loosen bolt (A, Figure 7) and position the blade guide assembly so that the guides rest just behind the gullet of the blade teeth (B, Figure 7). Tighten the bolt.
4. Loosen the knurled jam nuts (C, Figure 7) that lock the guide (D, Figure 7) in place.
5. Turn the knurled knob (E, Figure 7) so that the guides rest lightly against the blade, approximately 0.003" away from the side of the blade, about the thickness of a piece of paper. Do not force the guides against the side of the blade. Tighten knurled jam nuts while holding the knurled knobs.
6. Adjust the blade support bearing so that it is 0.003" away from the back of the blade, about the thickness of a piece of paper. To make this adjustment loosen bolt (F, Figure 7) and slide the bearing and bearing post into position. Tighten the bolt.

Squaring Table to the Blade

1. Disconnect machine from power source.
2. Blade tension, tracking and guide setup must be properly adjusted prior to squaring the table to the blade, see "Tensioning Blade" page 8, "Blade Tracking" page 9, "Adjusting Upper Blade Guides" page 9 and "Adjusting Lower Blade Guides" page 10.
3. Place a square (G, Figure 8) on the table against the blade to see if the table is 90 degrees to the blade.
4. If adjustment is necessary loosen trunnion bolt (H, Figure 9) and tilt table until it is square to the blade. Tighten trunnion bolt.
5. Loosen nut (I, Figure 9) and turn table stop bolt (J, Figure 9) until it contacts the table. Tighten the nut while holding the table stop bolt in place.
6. Check to see that the table is still square to blade and make any additional adjustments.

7. If necessary loosen screw (K, Figure 9) and adjust pointer to read zero.

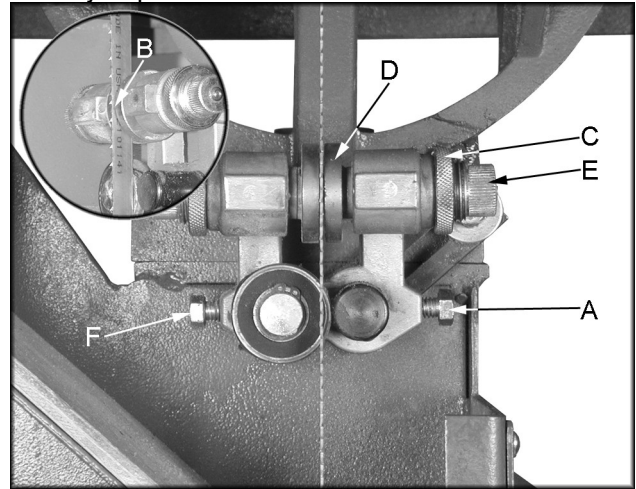

Figure 7

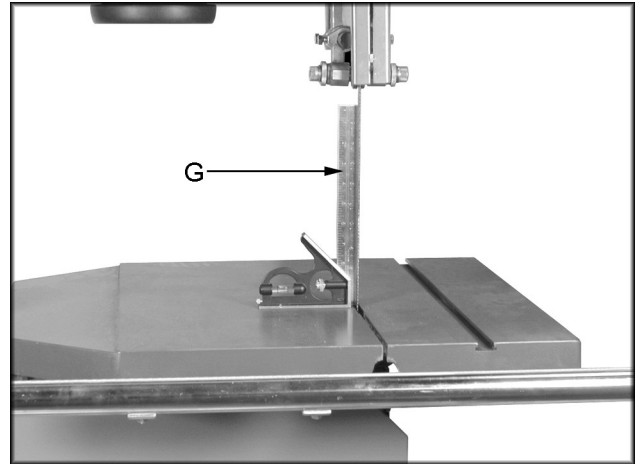

Figure 8

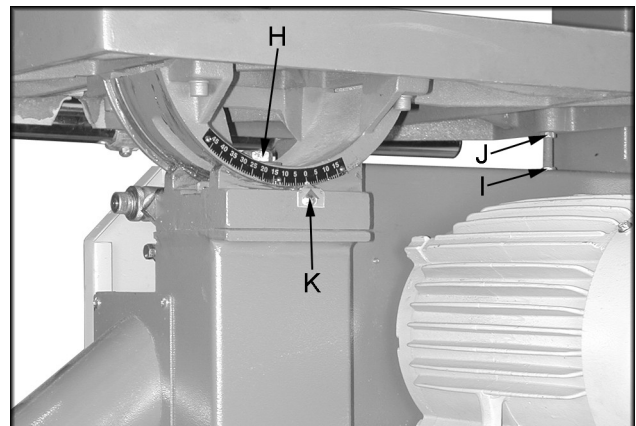

Figure 9

Fence and Rail Adjustment

1. Place the fence (A, Figure 10) on the table and guide tube. Use the knob (B, Figure 10) to secure the fence in place, or loosen to reposition fence.
2. Move the fence so that the blade's teeth just touch the fence, see Figure 10. Lock the fence in place using the knob.
3. The fence should be parallel to the blade. If not loosen the bolts (C, Figure 11) and adjust the guide tube until the fence is parallel to blade. Tighten the bolts.
4. Raise or lower the fence and guide tube by adding or subtracting flat washers (E, Figure 11) between the guide tube bracket and table.
5. With a square verify the fence face is perpendicular to the table top. If it is not you will need to shim between the guide tube bracket (D, Figure 11) and table at the low end of guide tube.
5. Check to see that the pointer (F, Figure 10) is aligned with the zero marking on the guide tube. If adjustment is necessary loosen the screw that holds the cursor in place and line up to the zero mark. Tighten the screw.
6. Move the fence to the opposite side of blade and check to make sure the cursor lines up with zero mark. If adjustment is necessary loosen the screw that holds the cursor in place and line up to the zero mark. Tighten the screw.

Electrical Connections

! WARNING

Electrical connections and wiring must be done by a qualified electrician. The machine must be properly grounded. Failure to comply may cause serious injury!

The bandsaw is available in both 1-Phase and 3-Phase versions.

Electrical Connections for a 3-Phase Unit

This bandsaw is 3-Phase, 220V/440V **pre-wired 220V**. If you need to switch the bandsaw from 220V to 440V have a qualified electrician make the changes. Oliver Machinery recommends using a dedicated circuit.

Make sure the voltage of your power supply matches the specifications on the motor plate of the machine.

1. **Disconnect machine from power source!**
2. Remove nuts that secure the cover to the connection box.
3. Insert the power cable through strain relief, and attach the wires to the terminals.
4. Re-install the connection box cover. With 3Ph power verify the blade is turning in the proper direction. Turn the bandsaw on and make sure the blade travels in a clockwise direction when viewed from the front. If it does not, disconnect the machine from power source and reverse any two incoming power leads.
5. When wiring is completed, tape all power box joints to keep out dust.

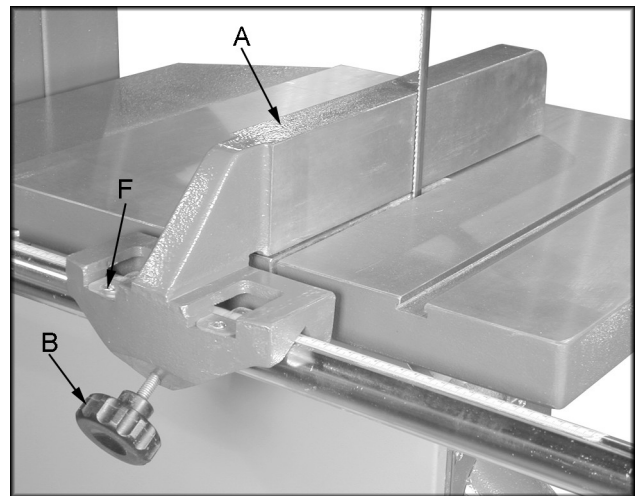

Figure 10

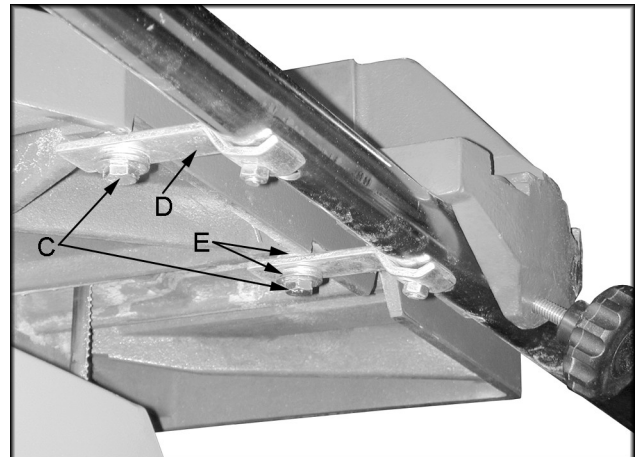

Figure 11

- **Electrical Connections for a 1-Phase Unit**

This bandsaw is 1-Phase, 220V only. Oliver Machinery recommends using a dedicated circuit.

Make sure the voltage of your power supply matches the specifications on the motor plate of the machine.

1. **Disconnect machine from power source!**

2. Remove nuts that secure the cover to the connection box.
3. Insert the power cable through strain relief, and attach the wires to the terminals.
4. Re-install the connection box cover.
5. When wiring is completed, tape all power box joints to keep out dust.

Miter Gauge

1. Slide the miter gauge bar into the miter gauge slot in table. Loosen the handle (A, Figure 12) and pull out indexing rod (B, Figure 12) to pivot the miter gauge body.
2. Push the indexing rod in to engage the preset stops.
3. Adjust stops by loosening the hex nut (C, Figure 12) and adjusting screw (D, Figure 12).
4. Align the cursor by loosening screw (E, Figure 12).

Note: Always make test cuts. The scale is for reference. There are two holes in the miter gauge fence used to attach a wooden fence.

Dust Collection

There is a 4" dust port (F, Figure 12) located on the side of cabinet. Make sure dust collection system has sufficient capacity and suction for your bandsaw. Always turn on dust collection system before starting the bandsaw.

Brake Pedal

Press the brake pedal (G, Figure 12) while the saw is running to stop the saw. Re-start the saw by pressing the on switch.

Tilting the Table

1. **Disconnect machine from power source.**
2. Loosen the trunnion bolt found in the center of the trunnions and tilt the table until the scale reads the desired angle. Tighten the bolt. **Note:** The scale is for reference and should be checked with a combination square if exact angles are needed.

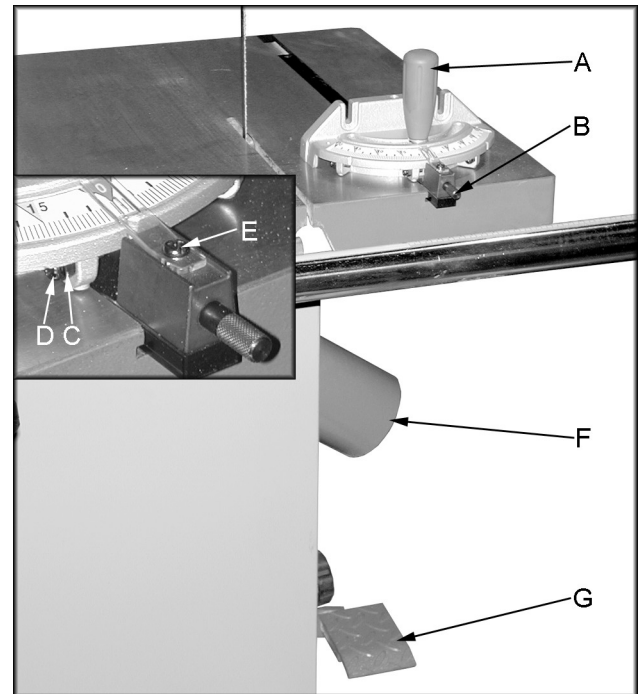

Figure 12

Removing Blades

! WARNING

Bandsaw blades are sharp so be very careful while handling. Failure to comply may cause serious injury!

1. Disconnect machine from power source.
2. Open upper and lower doors completely.
3. Put on leather gloves to protect your hands from the sharp teeth of blade.
4. Release blade tension and carefully remove blade from upper and lower wheels.

Replacing V-Belt

1. Disconnect machine from power source.
2. Release blade tension and carefully remove blade from upper and lower wheels.
3. Loosen the hex nut (A, Figure 13) and turn hex cap bolt (B, Figure 13) to lower the motor assembly. This will take tension off the v-belt. Stop when you can remove the v-belt from the motor pulley.
4. Unscrew the bolt (C, Figure 13). Loosen two of the shaft bolts (D, Figure 13) to remove lower wheel. **Note:** don't loosen hex nuts (E, Figure 13).
5. Remove lower wheel assembly (F, Figure 14) by pulling from the front side. If the lower wheel does not come off easily you may need to loosen another shaft bolt (D, Figure 13).
6. Remove the old belt (G, Figure 14) and replace with a new belt.
7. Reinstall the lower wheel assembly and make sure the v-belt is in the motor pulley groove and wheel pulley groove.
8. Tighten bolt (C, Figure 13) and tighten shaft bolts (D, Figure 13). Tighten hex nut (E, Figure 13).
9. Turn hex cap bolt to adjust the belt tension, see "Adjusting Belt Tension" page 13.
10. Reinstall the blade, see "Installing Blade" page 8.

11. Set the blade tension, see "Tensioning Blade" page 8.
12. Check the blade tracking, see "Blade Tracking" page 8.

Adjusting Belt Tension

1. Disconnect machine from power source.
2. Loosen the hex nut (A, Figure 13) and turn hex cap bolt (B, Figure 13) to raise or lower the motor assembly. This will add or remove tension to the v-belt.
3. Proper tension is achieved when there is a 1/4" deflection in the belt between pulleys with light finger pressure.

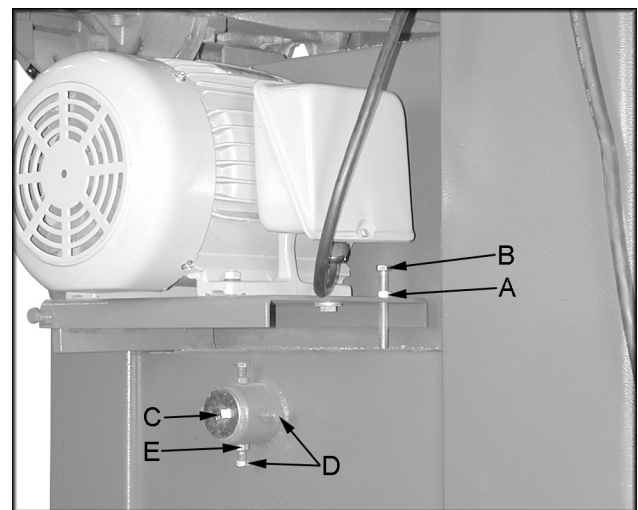

Figure 13

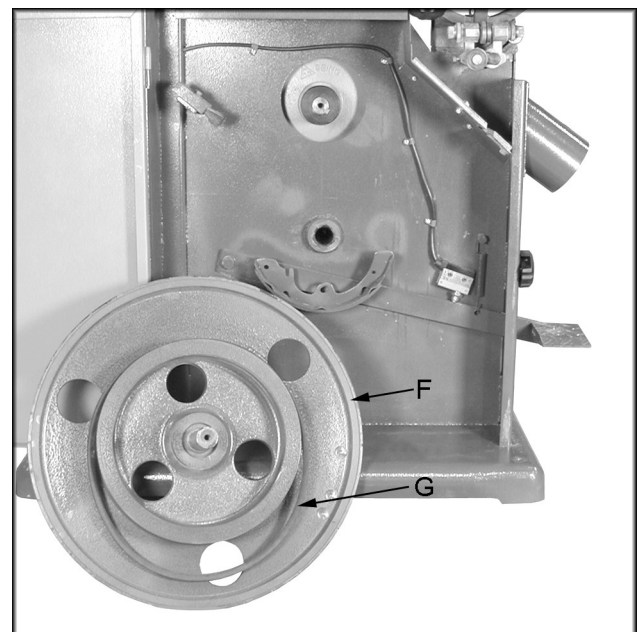

Figure 14

Maintenance

! WARNING

Disconnect the machine from power source before proceeding with any maintenance! Failure to comply may cause serious injury!

Periodically clean the inside of the machine for dust control. Use an air hose to blow out dust from motor fan and motor cover.

Keep the brake switch (A, Figure 15) clean and free of dust build up.

Adjust the lower wheel brush (B, Figure 15) to make contact with the tire as the brush wears.

Keep pulleys and belts free from dirt, dust, oil and grease.

Replace worn v-belt as needed.

Remove rust from the tabletop with WD-40 and a Scotch-Brite™ Hand Pad. Keep a light coat of WD-40 on the table top when not in use.

Keep the bandsaw blade sharp and clean.

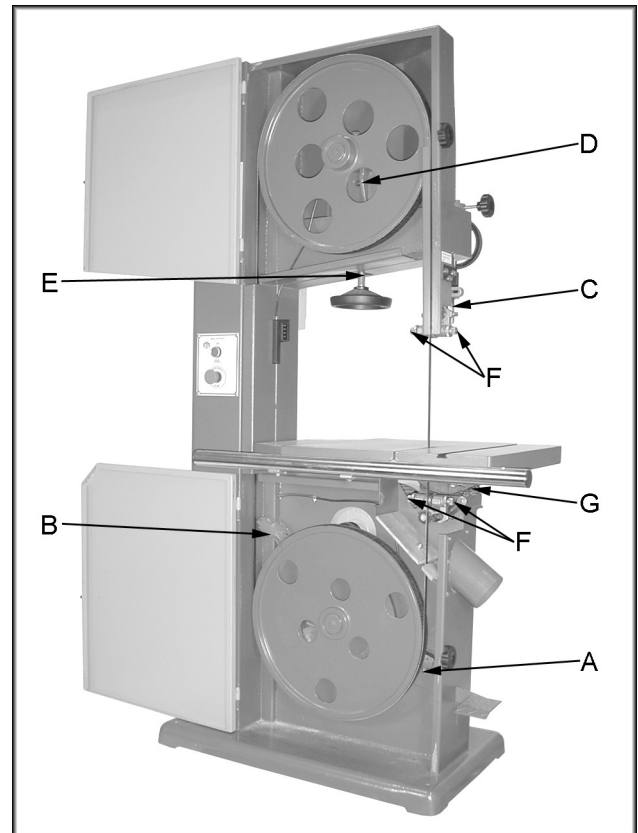

Figure 15

Lubrication

! WARNING

Disconnect the machine from power source before proceeding with any lubricating! Failure to comply may cause serious injury!

- Clean and grease upper guide raising and lowering rack (C, Figure 15) monthly, or as needed.
- Oil the dove tailed ways (D, Figure 15) that the upper wheel slides on for blade tension monthly, or as needed.
- Grease the tensioning screw (E, Figure 15) monthly, or as needed.
- The guides (F, Figure 15) require oil daily or every 8 hours of use. They have a ball valve for oiling. We recommend 10 weight, non-detergent oil.
- Use a cloth to clean trunnion (G, Figure 15). Apply white lithium grease to lubricate trunnions.

Troubleshooting

! WARNING

Disconnect the machine from power source before proceeding with any troubleshooting! Failure to comply may cause serious injury!

Description of Symptoms	Possible Cause	Corrective Action
Machine will not start	<ol style="list-style-type: none"> 1. Fuse blown or circuit breaker tripped 2. Cord Damaged 3. Faulty switch 4. Not connected to power source 5. Connected to wrong voltage 6. Emergency stop button pressed 	<ol style="list-style-type: none"> 1. Replace fuse or reset circuit breaker 2. Have cord replaced 3. Replace switch 4. Check connection 5. Check voltage 6. Rotate emergency stop button clockwise until it pops out
Blade does not come up to speed	<ol style="list-style-type: none"> 1. Cable too light or too long 2. Low current 3. Circuit shared with other equipment 4. Motor not wired for correct voltage 	<ol style="list-style-type: none"> 1. Replace with adequate size cable 2. Contact local electric company 3. Provide a dedicated circuit 4. Refer to motor nameplate for correct voltage
Motor overheats	<ol style="list-style-type: none"> 1. Motor overloaded 2. Air circulation through the motor restricted 	<ol style="list-style-type: none"> 1. Reduce load on motor 2. Clean out fan and fan cover
Machine slows when operating	<ol style="list-style-type: none"> 1. Feeding workpiece too fast 	<ol style="list-style-type: none"> 1. Slow the feed speed
Does not make accurate 45° or 90° cuts	<ol style="list-style-type: none"> 1. Stops not adjusted correctly 2. Angle pointer not set accurately 3. Miter gauge out of adjustment 	<ol style="list-style-type: none"> 1. Check blade with combination square and adjust stops 2. Check blade with combination square and adjust pointer 3. Adjust miter gauge
Saw makes unsatisfactory cuts	<ol style="list-style-type: none"> 1. Dull blade 2. Blade mounted backwards 3. Gum or pitch on blade 4. Incorrect blade for cut 	<ol style="list-style-type: none"> 1. Sharpen or replace blade 2. Turn blade around 3. Remove blade and clean 4. Change blade to correct type
Saw vibrates excessively	<ol style="list-style-type: none"> 1. Stand on uneven floor 2. Damaged saw blade 3. Bad V-belt 4. V-belt tension incorrect 5. Loose hardware 	<ol style="list-style-type: none"> 1. Reposition on flat, level surface 2. Replace saw blade 3. Replace V-belt 4. Check and adjust v-belt tension 5. Tighten hardware

4640 & 4665 Parts List

No.	Part Number	Description	Q'ty	Specification
1	HT011518	Hex HD Bolt	1	1/2-12NC*2
2	HX011500	Hex Nut	4	1/2-12NC
3	BQ010001	BRACKET	1	
4	BS010001	SHAFT	1	
5	BQ010003	BALL BEARING	2	
6	BQ010004	Bushing	2	
7	BQ010005	Sleeve	2	
8	BQ010006	BALL BEARING	2	
9	BS010002	UPPER WHEEL	1	
10	HF051300	C-Ring	2	CTW-62
11	BQ010008	Spacer	2	
12	HT011110	Round HD Bolt	4	3/8-16NC*1
13	BS010003	TIRE	2	
14	BS010004	Upper Wheel Tension Shaft	1	
15	HJ131500	Cusion Bracket	1	51200
16	BQ010011	Secure Plate	1	
17	BQ010012	Spring	1	
18	BQ010013	Tension Bracket	1	
19	BQ010014	Axis	1	
20	BQ010015	Washer	2	40.5*13*4.1t
21	BQ010016	Handle Wheel	2	
22	HB030806	Set Screw	3	5/16-18NC*1/2
23	HT010910	Hex HD Bolt	6	5/16-18NC-1
24	HE021100	Washer	2	8.2*15.4
25	BQ010017	Post Holder	1	
26	BS010005	Frame Ass'y	1	(BSW-24)
27	HF022800	E-Ring	2	RTW-30
28	BQ010018	KNOB	1	
29	BS010006	Guard Post	1	(BSW-24)
30	HT040905	Round HD Bolt	11	3/16-24NC*3/8
31	BS010007	Front Plate	1	(BSW-24)
32	BS010008	BLADE GUARD ASSY INCL	1	
33	BS010009	BRACKET	1	
34	HY012900	Washer	2	6.7*19*2.0t
35	HE021000	Start Washer	2	6.7*12.8
36	HT010706	Round HD Bolt	2	1/4-20NC*1/2
37	HX010700	Hex Nut	3	5/16-18NC
38	BQ010023	KNOB	1	
39	BQ010024	Guide Block	1	
40	BQ010025	Guide Bracket	1	

41	HY015200	Washer	9	8.5*23*1.5t
42	HT010908	Hex HD Bolt	8	5/16-18NC*3/4
43	HA020505	Socket HD Bolt	4	M8*1.25P*12
44	BQ010026	Guide Holder	2	
45	BQ010027	LOCK RING	4	
46	BQ010028	Guide Adaptor	1	
47	BQ010029	GUIDE	1	
48	BQ010030	BACKUP GUIDE	1	
49	BQ010031	Guide Post	1	
50				
51	HB020808	Socket HD Bolt	2	1/4-20NC*3/4
52	BQ010033	Door Knob	2	
53	HX010500	Hex Nut	1	1/4-20NC
54	HT011118	Hex HD Bolt	1	3/8-16NC
55	HX010900	Hex Nut	10	3/8-16NC
56	HT011112	Hex HD Bolt	7	3/8-16NC*1-1/4
57	BS010010	Dust Hood	1	
58	BS010011	Motor Pulley	1	
59	HH030727	Key	1	8*7*50
60	BS0A0101	Motor	1	3HP*220V~240V*1PH
61	HE021300	Spring Washer	9	10.2*18.5
62	BS010012	Pivot	1	
63	HY015700	Spring Washer	6	10.5*27*2.0t
64	BQ010037	MOTOR BASE	1	
65	BQ010038	Miter Guage Handle	1	
66	BQ010039	Miter Guage	1	
67	BQ010040	Slot Spacer	1	
68	BQ010041	Slot Bar	1	
69	BQ010042	Miter Indicator	1	
70	HT010708	Hex HD Bolt	1	1/4-20NC*3/4
71	BQ010043	Washer	1	
72	BQ010044	Pivot		
73	HB021012	Hex HD Bolt	4	3/8-16NC*1-1/4
74	HT011512	Hex HD Bolt	1	1/2-12NC*1-1/4
75	HE021600	Washer	1	13*22.7
76	BQ010045	Pivot support	1	
77	BQ010046	BRACKET	1	
78	BQ010047	Guide Connector	1	
79	BS010013	TABLE	1	
80	BS010014	Fence Rail	1	
81	BQ010050	KNOB	1	
82	BQ010051	Spring	1	

83	HT011108	Hex HD Bolt	1	3/8-16NC*3/4
84	BQ010052	PEDAL	1	
85	BS010015	Brace	1	
86	BQ010054	BRAKE ASSY	1	
87	BQ010055	HINGE PIN	1	
88	BQ010056	SUPPORT	1	
89				
90	BS010016	SHAFT	1	
91	BS010017	LOWER WHEEL	1	
92				
93	BQ010061	BRUSH	1	
94	BQ010062	BRUSH	1	
95	BS010018	Belt	2	
96	BQ010064	HINGE PIN	4	
97	BS010019	UPPER DOOR INCL	1	
98	BS010020	LOWER DOOR	1	
99	HB020805	Socket HD Bolt	2	1/4-20NC*3/8
100	BQ010067	Fence Ass'y	1	
101	HA040604	Round HD Bolt	2	M5*0.8P*10
102	HE011100	Washer	2	5.2*10*1t
103	BQ010068	Fence Pointer	2	
104	PJ080015	Switch OFF	1	
105	PJ080016	Switch ON	1	
106	HB190606	Round HD Bolt	2	#10-24*1/2"
107	BQ010069	Switch Plate	1	
108	PJ0B0K01	Switch Control Box	1	3HP*220V~240V*1PH
109	BQ1A0102	Serial Label	1	
110	BQ1A0103	Instruction Label	1	
111	BS1A0101	Scale	1	
112	BQ010070	Limited Switch	1	
113	BQ010071	Tension Indicator	1	
114	BQ010072	TENSION SCALE	1	
115	HA020507	Socket HD Bolt	1	M8*1.25P*15
116	HE015400	Washer	1	8.5*20*2.0t
117	HJ020300	Bearing	1	608ZZ
118	BS010021	Guide Adj. Disk	1	
119	BQ010074	GEAR SHAFT	1	

