



# 4620 14" Bandsaw

## Owner's Manual



**Oliver Machinery**  
Seattle, WA  
[info@olivermachinery.net](mailto:info@olivermachinery.net)

**M-4620 1/2021**  
© Copyright 2003  
[www.olivermachinery.net](http://www.olivermachinery.net)

# **SAFETY RULES**

**WARNING: FAILURE TO FOLLOW THESE RULES MAY RESULT IN SERIOUS PERSONAL INJURY.**

- 1. FOR YOUR OWN SAFETY, READ INSTRUCTION MANUAL BEFORE OPERATING THE TOOL.** Learn the tool's application and limitations as well as the specific hazards peculiar to it.
- 2. KEEP GUARDS IN PLACE** and in working order.
- 3. ALWAYS WEAR EYE PROTECTION.** Wear safety glasses. Everyday eyeglasses only have impact resistant lenses; they are not safety glasses. Also use face or dust mask if cutting operation is dusty. These safety glasses must conform to ANSI Z87.1 requirements.  
Note: Approved glasses have Z87 printed or stamped on them.
- 4. REMOVE ADJUSTING KEYS AND WRENCHES.** Form habit of checking to see that keys and adjusting wrenches are removed from tool before turning it on.
- 5. KEEP WORK AREA CLEAN.** Cluttered areas and benches invite accidents.
- 6. DON'T USE IN DANGEROUS ENVIRONMENT.** Don't use power tools in damp or wet locations, or expose them to rain. Keep work area well lighted.
- 7. KEEP CHILDREN AWAY.** All visitors should be kept safe distance from work area.
- 8. MAKE WORKSHOP KID PROOF** with padlocks, master switches, or by removing starter keys.
- 9. DON'T FORCE TOOL** it will do the job better and safer at the rate for which it was not designed.
- 10. USE THE RIGHT TOOL.** Don't force a tool or attachment to do a job for which it was not designed.

11. **USE PROPER EXTENSION CORD.** Make sure your extension cord is in good condition. When using an extension cord, be sure to use one heavy enough to carry the current your product will draw. An undersized cord will cause a drop in line voltage resulting in loss of power and overheating. Table 1 shows the correct size to use depending on cord length and nameplate ampere rating. If in doubt, use the next heavier gage. The smaller the gage number, the heavier the cord.
12. **WEAR PROPER APPAREL** Do not wear loose clothing, gloves, neckties, rings, bracelets, or other jewelry which may get caught in moving parts. Nonslip footwear is recommended. Wear protective hair covering to contain long hair.
13. **ALWAYS USE SAFETY GLASSES.** Also use face or dust mask if cutting operation is dusty. Everyday eyeglasses only have impact resistant lenses, they are NOT safety glasses.
14. **SECURE WORK.** Use clamps or a vise to hold work when practical. It's safer than using your hand and it frees both hands to operate tool.
15. **DON'T OVERREACH.** Keep proper footing and balance at all times.
16. **MAINTAIN TOOLS WITH CARE.** Keep tools sharp and clean for best and safest performance. Follow instructions for lubricating and changing accessories.
17. **DISCONNECT TOOLS** before servicing; when changing accessories, such as blades, bits, cutters, and the like.
18. **REDUCE THE RISK OF UNINTENTIONAL STARTING.** Make sure switch is in off position before plugging in.
19. **USE RECOMMENDED ACCESSORIES.** Consult the owner's manual for recommended accessories. The use of improper accessories may cause risk of injury or persons.
20. **NEVER STAND ON TOOL** Serious injury could occur if the tool is tipped or if the cutting tool is unintentionally contacted.

21. **CHECK DAMAGED PARTS.** Before further use of the tool, a guard or other part that is damaged should be carefully checked to determine that it will operate properly and perform its intended function-check for alignment of moving parts, binding of moving parts, breakage of parts, mounting, and any other conditions that may affect its operation. A guard or other part that is damaged should be properly repaired or replaced.
22. **DIRECTION OF FEED.** Feed work into a blade or cutter against the direction of rotation of the blade or cutter only.
23. **NEVER LEAVE TOOL RUNNING UNATTENDED. TURN POWER OFF.**  
Don't leave tool until it comes to a complete stop.
24. **MAKE SURE TOOL IS DISCONNECTED** from power supply while motor is being mounted, connected or reconnected.

### **PROP 65 NOTICE**

**WARNING:** Drilling, sawing, sanding or machining wood products can expose you to wood dust, and/or other chemicals known to the State of California to cause cancer, birth defects or other reproductive harm.

Some examples of these chemicals are:

- Lead from lead-based paints.
- Crystalline silica from bricks, cement and other masonry products.
- Arsenic and chromium from chemically-treated lumber.

Avoid inhaling wood dust and other harmful chemicals. Use a dust mask and/or other safety devices for personal protection.

For more information go to <http://www.P65Warnings.ca.gov/wood>

# **SAVE THESE INSTRUCTIONS**

## **ADDITIONAL SAFETY RULES FOR BAND SAWS**

1. If you are not thoroughly familiar with the operation of band saws, obtain advice from your supervisor, instructor or other qualified person.
2. Follow all wiring codes and recommended electrical connections. Make certain that the tool is properly grounded.
3. Make all adjustments with the power "OFF"
4. Always maintain proper adjustment of blade tension, blade guides, and blade support bearings.
5. Avoid awkward hand positions. A sudden slip could allow the hand to contact the blade.
6. Do not attempt to saw stock that does not have a flat surface, unless a suitable support is used.
7. Make sure blade is not contacting the workpiece before turning on the power switch.
8. Always keep hands and fingers away from the blade when the machine is running.
9. Hold workpiece firmly against table and feed into blade at a moderate speed.
10. Make sure that the saw blade teeth point downward toward the table.
11. Adjust upper guide to just clear work piece.
12. Disconnect machine from the power source when making repairs.
13. Replace all guards after servicing.
14. Turn off band saw if the material is to be backed out of an uncompleted cut.

15. Make relief cuts before cutting long curves.
16. Do not cut material that is too small to be safely supported.
17. Support long heavy work from the floor.
18. Before leaving the machine, make sure the work area is clean.
19. Important: When the tool is not in use , the switch should be in the “OFF” position and the power cord disconnected.
20. Do not remove jammed cutoff pieces until blade has stopped.

ON-OFF SWITCH PADLOCK – To safeguard the band saw from unauthorized operation and to avoid accidental starting by children or other not qualified to use, the use of padlock is required. To lock out the on – off switch, open the padlock, insert through the hole of the switch on button and close the padlock. Place the key in a location that is inaccessible to children and other not qualified to use the tool.

# GROUNDING INSTRUCTIONS

All grounded, cord-connected tools:

- In the event of a malfunction or breakdown, grounding provides a path of least resistance for electric current to reduce the risk of electric shock. This tool is equipped with an electric cord having an equipment-grounding conductor and a grounding plug.
- The plug must be plugged into a matching outlet that is properly installed and grounded in accordance with all local codes and ordinances.
- Do not modify the plug provided – if it will not fit the outlet, have the proper outlet installed by a qualified electrician.
- Improper connection of the equipment-grounding conductor can result in a risk of electric shock. The conductor with insulation having an outer surface that is green with or without yellow stripes is the equipment-grounding conductor. If repair or replacement of the electric cord or plug is necessary, do not connect the equipment-grounding conductor to a live terminal.
- Check with a qualified electrician or service personnel if the grounding instructions are not completely understood, or if in doubt as to whether the tool is properly grounded.
- Use only 3-wire extension cords that have 3-prong grounding plugs and pole receptacles that accept the tool's plug.
- Repair or replace damaged or worn cord immediately.

# WARNING PLATES

This machine has warning symbols attached on it as shown below to ensure proper and safe operation.

These symbols are used on the machine to indicate points or instances of specific danger to operating personnel.

Make sure to memorize these symbols and bring them to the attention of others as and when necessary. **Do not remove safety symbols from the machine.**





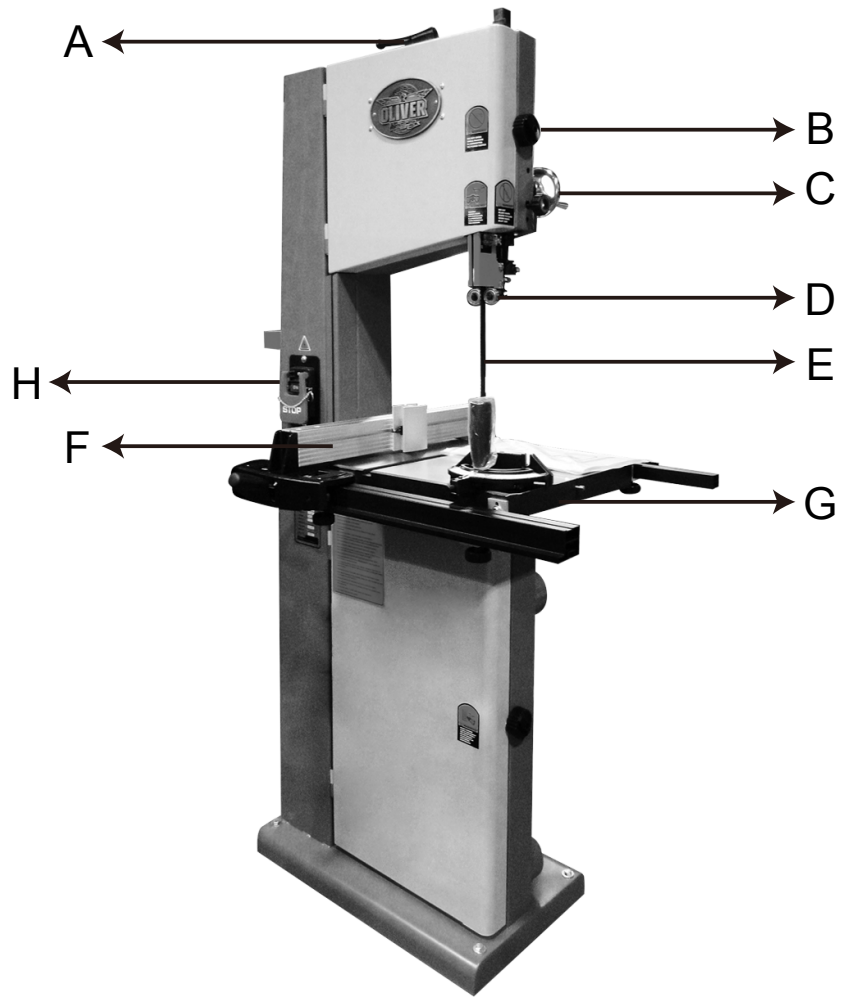

- A. Quick Release Tension Handle**
- B. Door Knob**
- C. Handwheel**
- D. Ball Bearing Guide Support**
- E. Blade**
- F. Fence**
- G. Working Table**
- H. Switch**

# FEATURES

- ❑ Motor – 2HP, Single Phase 110/220 Volts. (Pre-wired 110V Plug)
- ❑ Motor Speed – 3450 RPM.
- ❑ Motor Switch – ON/OFF SWITCH.
- ❑ Blade Speed – 1,480, 2,300 & 3,260 FPM.
- ❑ Fully Balanced Cast Iron Wheels.
- ❑ Table Size – 16" X 20" .
- ❑ Table Material – Precision Ground Cast Iron.
- ❑ Table Height – 37"
- ❑ Table Tilts – 45° left, 10° right.
- ❑ Throat – 13 1/2"
- ❑ Cutting Height – 13" rack & pinion adjustment.
- ❑ Blade Size – 1/4" – 1" 2890mm(113 3/4") long.
- ❑ Miter Gauge – 'T' Slot, Included.
- ❑ Overall Height – 76"
- ❑ Gross Weight – 304 lbs.

# INSTALLATION

## SAFETY RULES FOR MACHINE LIFTING

1. Pay special attention to the balance of the machine while lifting.
2. Use a forklift with sufficient loading capacity to lift the machine.
3. Have another person help guide the way when lifting the machine.
4. The forks of forklift must protrude from under the machine underside.
5. The forklift must only be driven by an experienced forklift driver.

This is a heavy machine. Serious personal injury may occur if safe moving methods are not used. To be safe, get assistance and use power equipment to move the shipping crate and remove the machine from the crate.

Although not required, we recommend that you mount your new machine to the floor.

Because this is an optional step and floor materials may vary, floor mounting hardware is not included. Generally, you can either bolt your machine to the floor or mount it on machine mounts. Both options are described below. Whichever option you choose, it is necessary to level your machine with a precision level.

## SELECTION OF LOCATION

Requirement of operating environment the operating temperature for this machine should be between  $+5^{\circ}\text{C}$  and  $+40^{\circ}\text{C}$ , while the relative humidity should not exceed 50% at a maximum temperature of  $+40^{\circ}\text{C}$ .

Improper environment will affect the machine's safe operation, avoid the following working area:

Avoid placing in area where the machine will rock or be uneven, thus preventing the machine from falling or turning over. This will prevent injuries and undue wear on the machine.

Avoid placing in places where vibration may occur. Install the machine at the anticipated place.

Whether there is any dust on the sliding surface or any defect. Clean it first to avoid setting off sparks or causing an electrical shock.

### Space allocation

Consider the largest size of workpiece that will be processed through this machine and provide enough space around the machine for adequate operator material handling or the installation of auxiliary equipment. With permanent installations, leave enough space around

the machine to open or remove doors/covers as required by the maintenance and service described in this manual.

### **Electrical Installation**

Place this machine near an existing power source. Make sure all power cords are protected from traffic, material handling, moisture, chemicals, or other hazards. Make sure to leave access to a means of disconnection the power source or engaging a lockout/tagout device.

### **Lighting**

Lighting around the machine must be adequate enough that operations can be performed safely. Shadows, glare, or strobe effects that may distract or impede the operator must be eliminated.

## **TRANSPORTATION**

Carefully check over the machine whether it is damaged during transportation.

While moving the machine, be sure to note its weight distribution as well as its balance.

If the machine is damaged while being moved, please contact the manufacturer immediately.

The lifting of the machine is as easy as follows:

The machine can be lifted by a forklift.

Their forks should insert through the machine bottom.

Attention should be paid to the balance of the machine while lifting.

# **POWER SUPPLY REQUIREMENT**

Insufficient voltage from factory power source may affect the power output of the motor and the function of the controller.

It is important to connect this machine to the correct voltage in the factory power source. Use only an independent power source.

# ADJUSTMENT

## TABLE ASSEMBLY

1. Place table bracket on the bandsaw so that the two bracket pins can go into the holes on the support.
2. Secure table bracket to bandsaw body using the two hex head bolt and flat washers(Fig.1)
3. Set table on bracket, insert screw into bracket and secure with knob



## ADJUSTING TO 90° TABLE STOP

1. Disconnect the machine from the power source.
2. Loosen the lock knobs (A) as illustrated in (Fig.) tilt the table towards the left until it rests against the table stop bolt.(Fig.,B)
3. Use a square, place on the table against the blade. This will allow you to verify the 90 degree to the table.
4. Turn table stop bolt to get the 90-degree angle; tighten the lock knobs once completed.

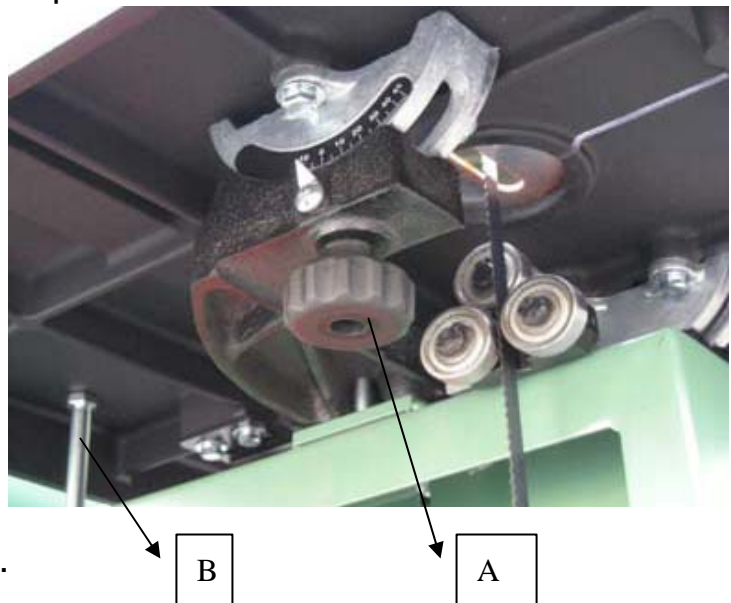

## TILTING THE TABLE

The bandsaw table tilts up 45° to the right or up to 10° to the left. TO tilt the table(Fig.)

1. Loosen knob under the table(Fig. A)&(Fig.,C).
2. Tilt table the desired angle of degree, gauge under the table.
3. Re-tighten knob.

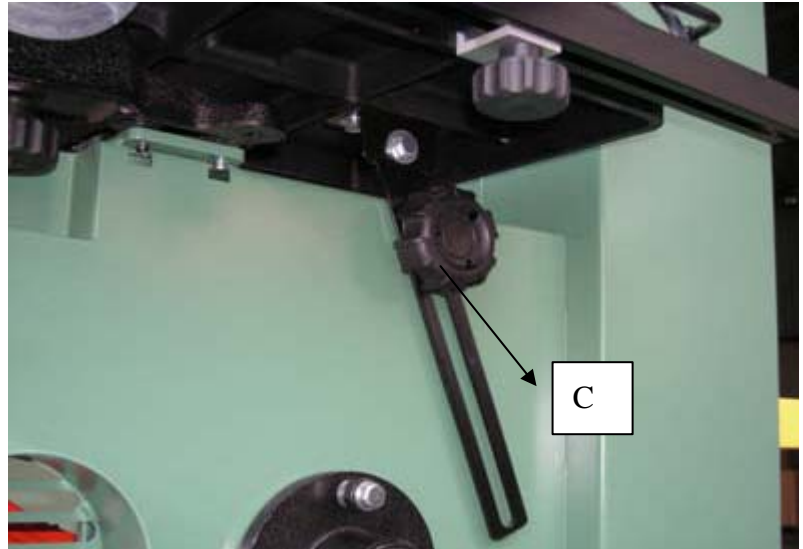

## Quick release / blade tensioning

Lifting the quick release handle to release blade tension. Remove blade and replace with new one. Turn down the handle to tighten blade.

Turn the handle clockwise to minor tighten blade tension and counterclockwise to release blade tension. A blade under tension may also pull drive wheel out of alignment. Adjust alignment of drive wheel with tracking knob.

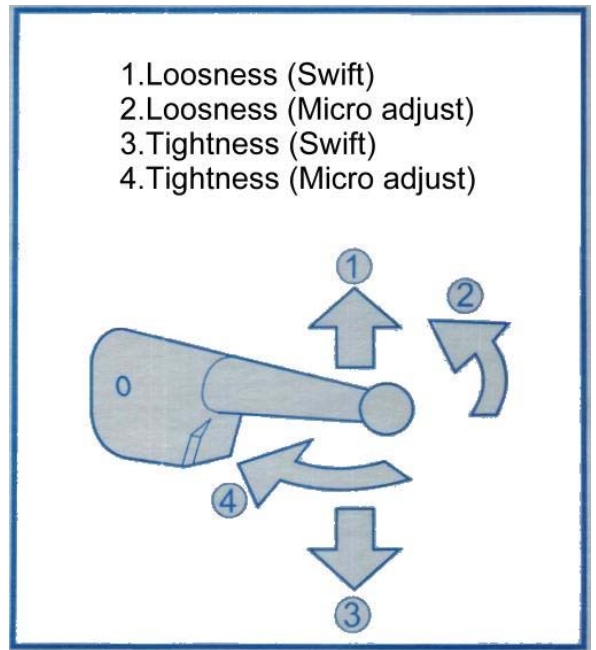

## Adjusting upper blade support

The blade support bearing (A) should be adjusted so it almost touches the back of the saw blade when the blade is tracking properly. To adjust, loosen indexable locking lever (B) and slide bracket in or out until the adjustment is correct. Tighten lever. The blade guide bearing (C) should be adjusted so they almost touch the slide of the blade. The front edge of the guide bearings must be positioned just behind the “gullets” of the saw teeth. To adjust, loosen indexable locking lever (D) and slide bearing assembly in or out until the adjustment is correct. Tighten lever. Replace blade guard.

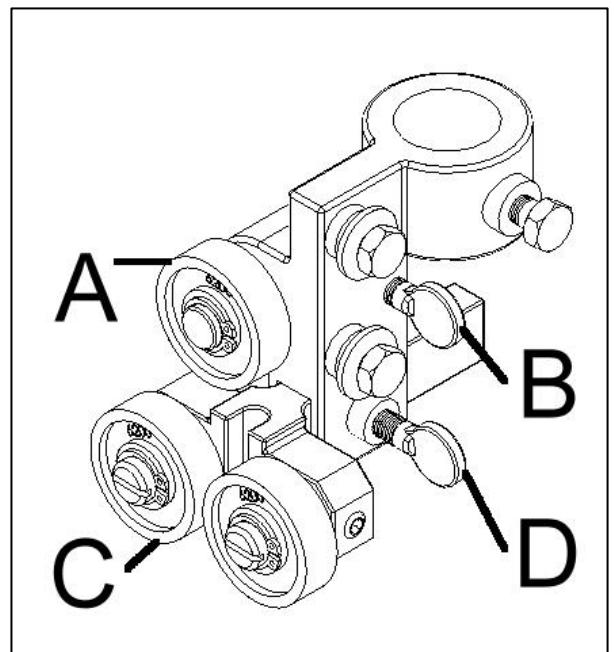



## Adjusting lower blade support bearing

The lower bearing adjustments are similar to the upper bearing adjustments. The blade support bearing (A) should be adjusted so it almost touches the back of the saw blade. To adjust, loosen hex screw (B) and slide bracket in or out until the adjustment is correct. Tighten screw. The blade guide bearings (C) should be adjusted so they almost touch the sides of the blade. To adjust, loosen hex screw (D) and slide bearing assembly in or out until the adjustment is correct. Tighten hex screw.

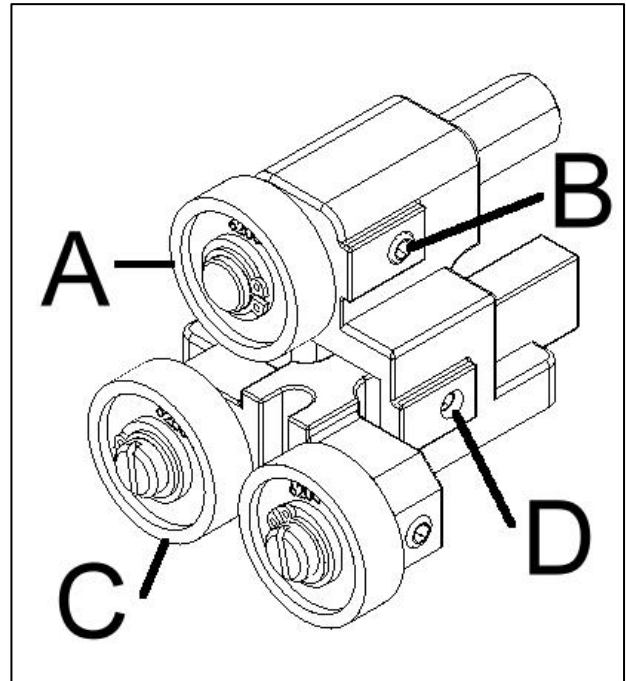

# FENCE ASSEMBLY

1.

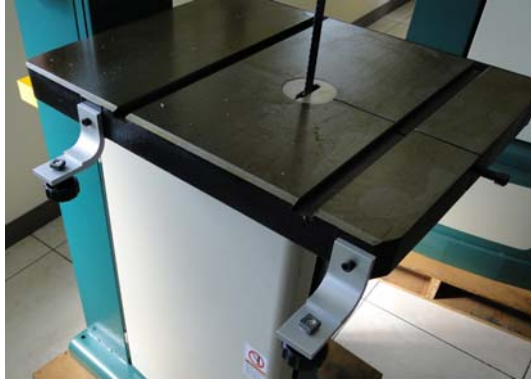

5.

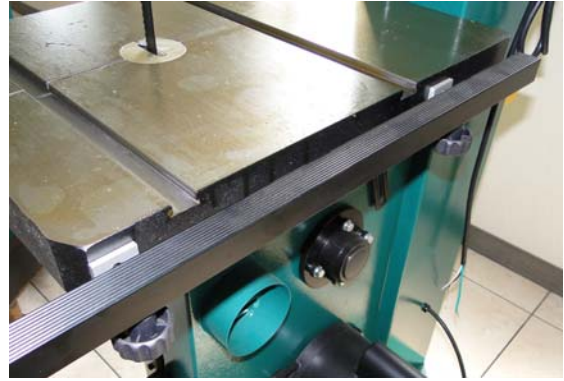

2.



6.



3.

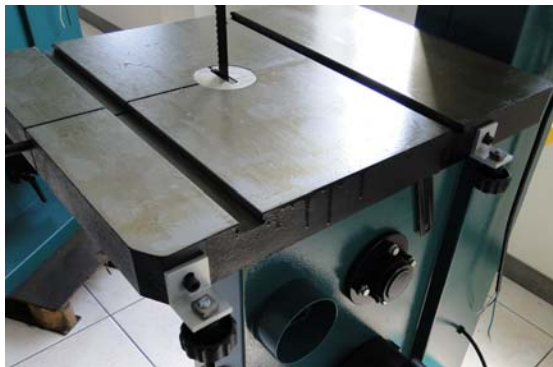

7.

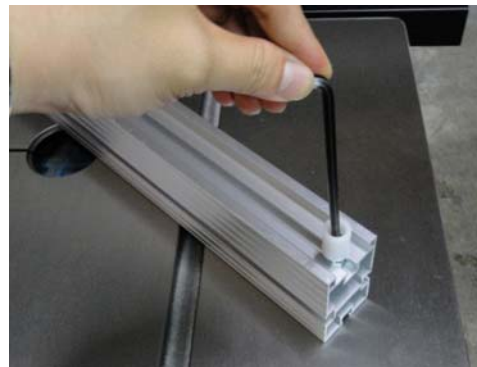

4.



8.



9.

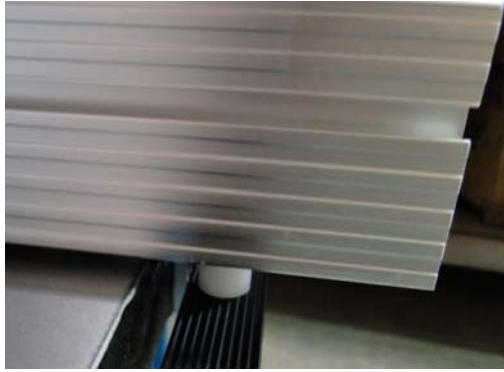

13.



10.

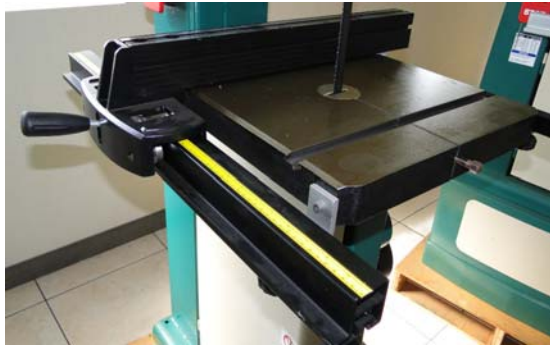

14.



11.



15.

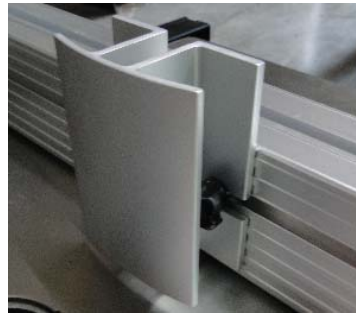

12.

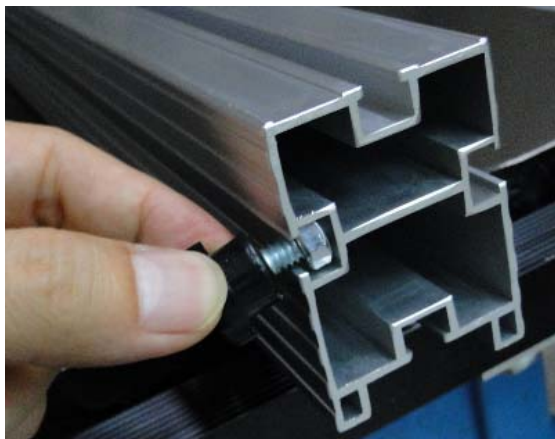

# FENCE ADJUSTMENT

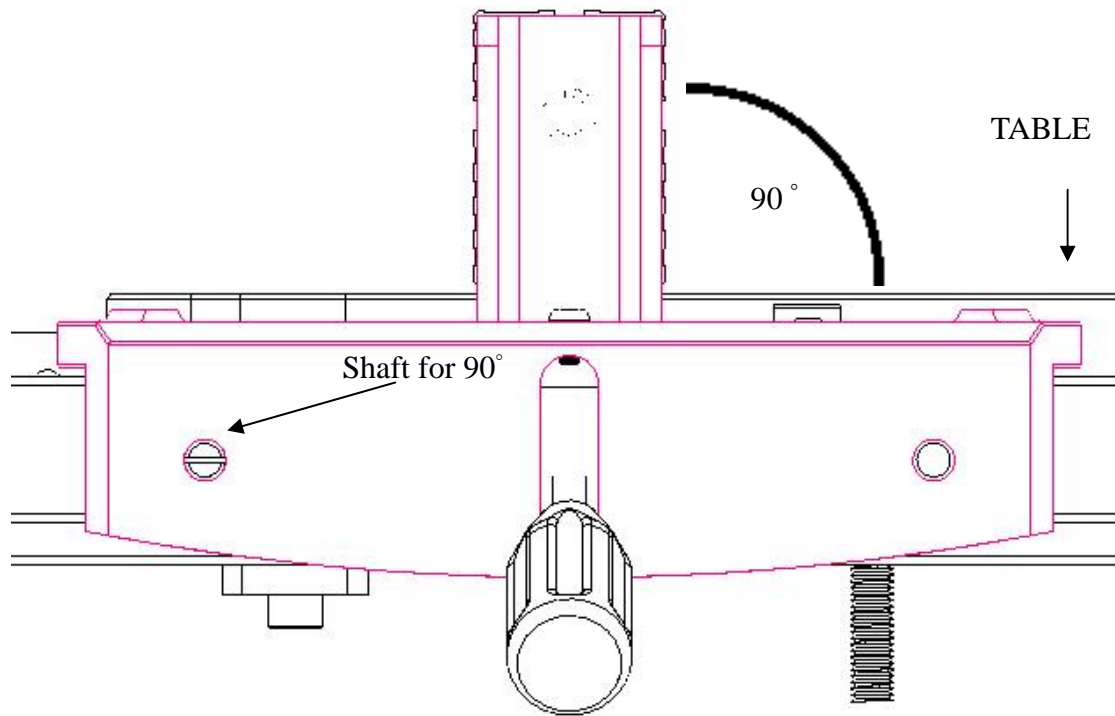
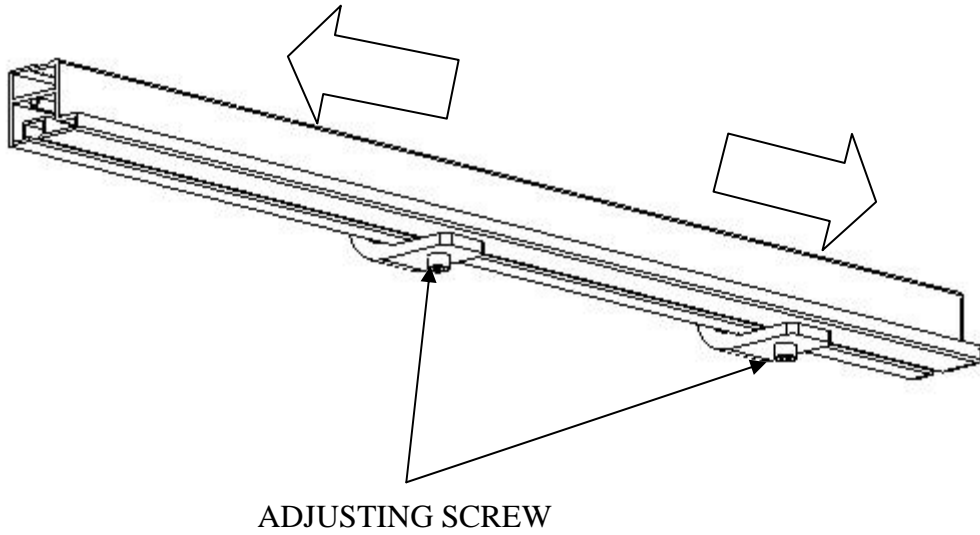

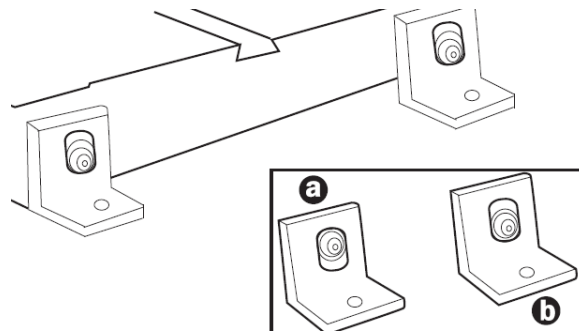
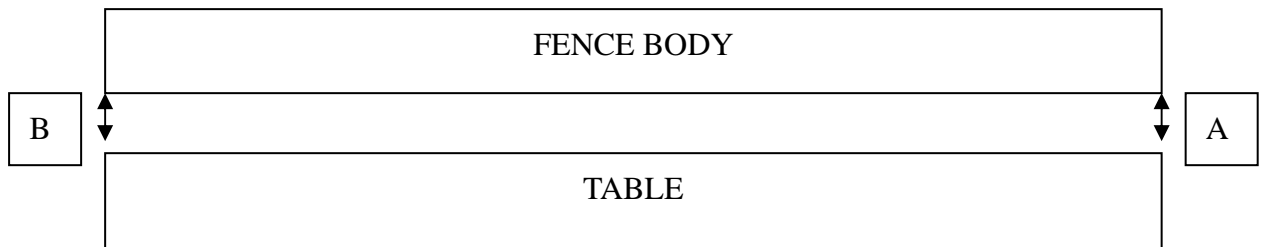

To level and adjust the height of the fence, loosen the bolt that hold the mounting brackets to the table, and raise or lower the front rails along the elongated holes in the mounting brackets. Level the fence, front and back as needed, and set the spacing between the bottom of the fence and the table to 1mm (approx.) as shown in image. Then, tighten the bolt to lock the rails in position

# Troubleshooting

## ! WARNING

Disconnect the machine from power source before proceeding with any troubleshooting! Failure to comply may cause serious injury!

Description of Symptoms	Possible Cause	Corrective Action
Machine will not start	<ol style="list-style-type: none"> <li>1. Fuse blown or circuit breaker tripped</li> <li>2. Cord Damaged</li> <li>3. Faulty switch</li> <li>4. Not connected to power source</li> <li>5. Connected to wrong voltage</li> <li>6. Emergency stop button pressed</li> </ol>	<ol style="list-style-type: none"> <li>1. Replace fuse or reset circuit breaker</li> <li>2. Have cord replaced</li> <li>3. Replace switch</li> <li>4. Check connection</li> <li>5. Check voltage</li> <li>6. Rotate emergency stop button clockwise until it pops out</li> </ol>
Blade does not come up to speed	<ol style="list-style-type: none"> <li>1. Cable too light or too long</li> <li>2. Low current</li> <li>3. Circuit shared with other equipment</li> <li>4. Motor not wired for correct voltage</li> </ol>	<ol style="list-style-type: none"> <li>1. Replace with adequate size cable</li> <li>2. Contact local electric company</li> <li>3. Provide a dedicated circuit</li> <li>4. Refer to motor nameplate for correct voltage</li> </ol>
Motor overheats	<ol style="list-style-type: none"> <li>1. Motor overloaded</li> <li>2. Air circulation through the motor restricted</li> </ol>	<ol style="list-style-type: none"> <li>1. Reduce load on motor</li> <li>2. Clean out fan and fan cover</li> </ol>
Machine slows when operating	<ol style="list-style-type: none"> <li>1. Feeding workpiece too fast</li> </ol>	<ol style="list-style-type: none"> <li>1. Slow the feed speed</li> </ol>
Does not make accurate 45° or 90° cuts	<ol style="list-style-type: none"> <li>1. Stops not adjusted correctly</li> <li>2. Angle pointer not set accurately</li> <li>3. Miter gauge out of adjustment</li> </ol>	<ol style="list-style-type: none"> <li>1. Check blade with combination square and adjust stops</li> <li>2. Check blade with combination square and adjust pointer</li> <li>3. Adjust miter gauge</li> </ol>
Saw makes unsatisfactory cuts	<ol style="list-style-type: none"> <li>1. Dull blade</li> <li>2. Blade mounted backwards</li> <li>3. Gum or pitch on blade</li> <li>4. Incorrect blade for cut</li> </ol>	<ol style="list-style-type: none"> <li>1. Sharpen or replace blade</li> <li>2. Turn blade around</li> <li>3. Remove blade and clean</li> <li>4. Change blade to correct type</li> </ol>
Saw vibrates excessively	<ol style="list-style-type: none"> <li>1. Stand on uneven floor</li> <li>2. Damaged saw blade</li> <li>3. Bad V-belt</li> <li>4. V-belt tension incorrect</li> <li>5. Loose hardware</li> </ol>	<ol style="list-style-type: none"> <li>1. Reposition on flat, level surface</li> <li>2. Replace saw blade</li> <li>3. Replace V-belt</li> <li>4. Check and adjust v-belt tension</li> <li>5. Tighten hardware</li> </ol>

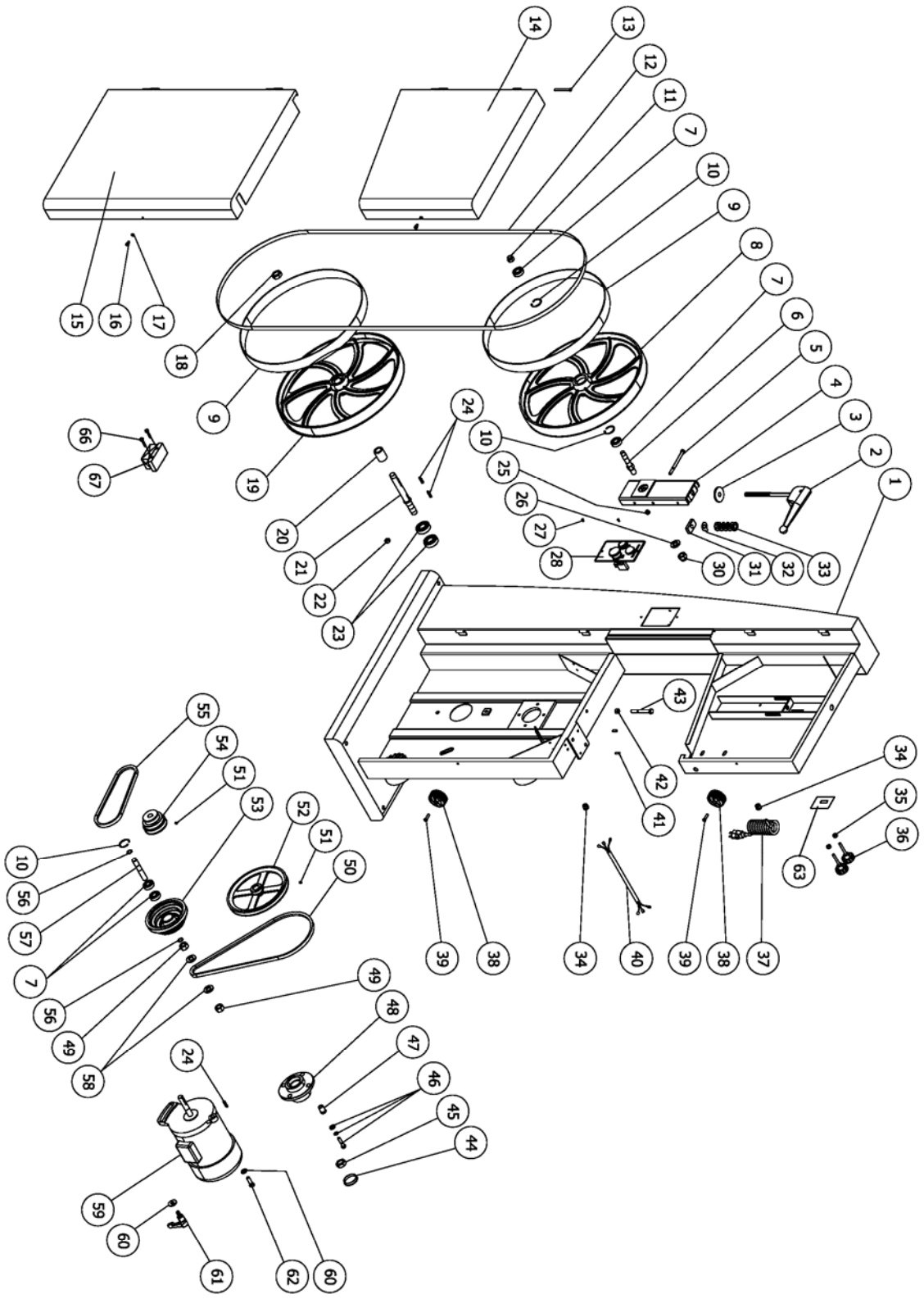

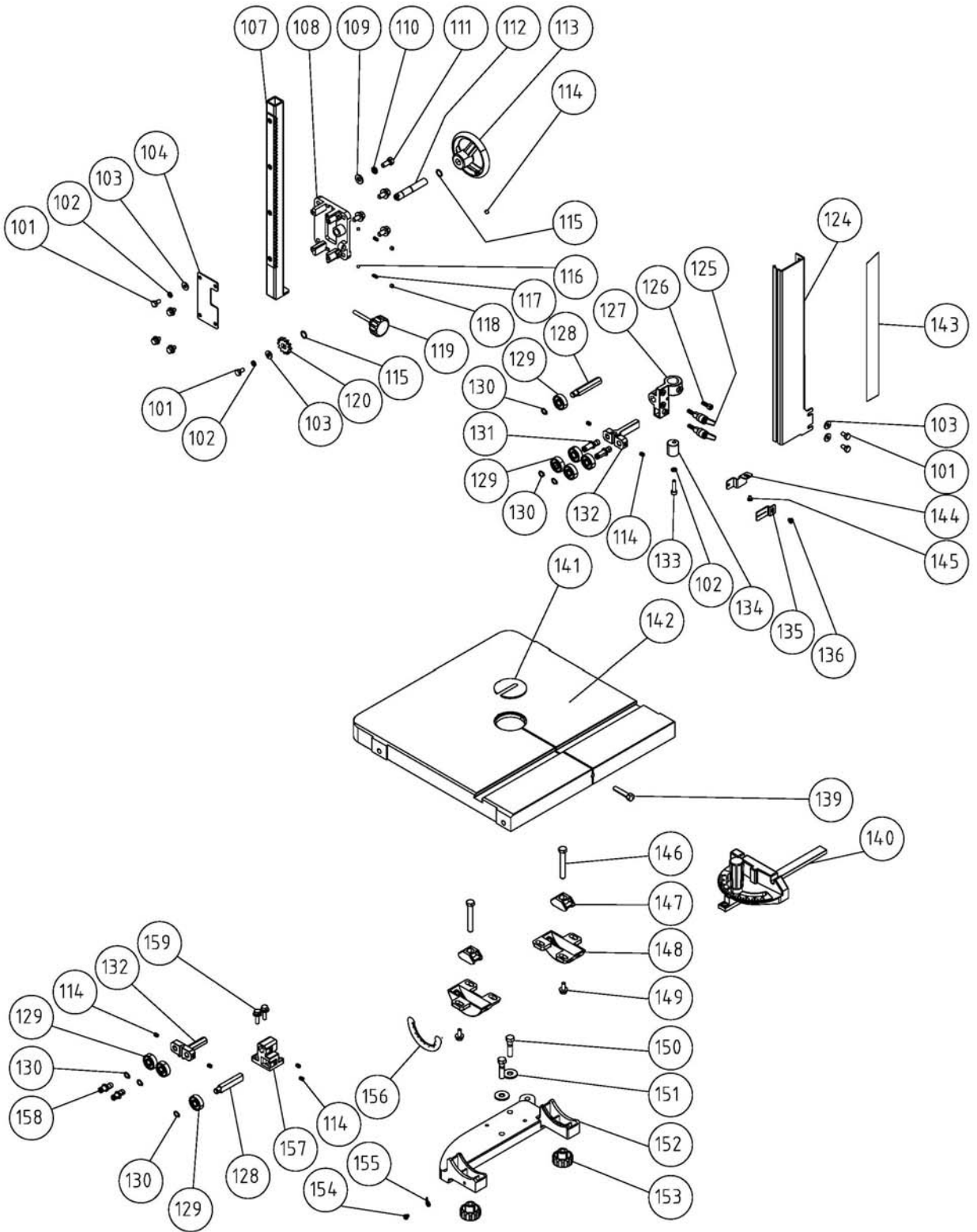



<b>PART</b>	<b>DESCRIPTION</b>	<b>PART</b>	<b>DESCRIPTION</b>
1	BODY	34	RETAINER
2	HANDLE	35	5/16" HEX NUT
3	WASHER	36	KNOB
4	UPPER WHEEL BRACKET	37	CORD
5	SCREW	38	KNOB
6	UPPER WHEEL SHAFT	39	1/4"-3/4" SOC HD SCREW
7	BEARING	40	CORD
8	UPPER WHEEL	41	6mm PIN
9	TIRE	42	3/8" HEX NUT
10	C-RING	43	3/8"-5" SCREW
11	1/2" HEX NUT	44	COVER
12	BLADE	45	3/4" HEX NUT
13	PIN	46	SCREW
14	UPPER WHEEL GUARD	47	ADJUSTING SCREW
15	LOWER GUARD	48	BEARING HOUSING
16	1/4"-3/8" SCREW	49	5/8" HEX NUT
17	1/4" LOCK WASHER	50	BELT
18	3/4" HEX NUT-L	51	1/4"-3/8" SET SCREW
19	LOWER WHEEL	52	PULLEY
20	SPACER	53	PULLEY
21	SHAFT	54	MOTOR PULLEY
22	3/8" HEX NUT	55	BELT
23	BEARING	56	C-RING
24	KEY 5x5	57	SHAFT
25	NUT	58	5/8" WASHER
26	1/2" WASHER	59	MOTOR
27	3/16"-1/2" PAN HD SCREW	60	3/8" WASHER
28	SWITCH	61	KNOB
30	1/2" NUT	62	3/8"-2 1/2" SCREW
31	SQUARE NUT	66	3/16*1/2 SCREW
32	POINTER	67	BRUSH
33	SPRING		

<b>PART</b>	<b>DESCRIPTION</b>	<b>PART</b>	<b>DESCRIPTION</b>
101	1/4"-3/8" SCREW	134	GUIDE POST
102	1/4" LOCK WASHER	135	POINTER
103	1/4" WASHER	136	3/16" SCREW
104	GUIDE BAR COVER	137	
105	M5 SCREW	138	
106	GEAR	139	PIN
107	GUIDE BAR	140	GAUGE
108	BRACKET	141	TABLE INSERT
109	5/16" WASHER	142	TABLE
110	5/16" LOCK WASHER	143	SCALE
111	5/16"-5/8" SCREW	144	POINTER PLATE
112	SHAFT	145	1/4"-3/8" SCREW
113	HAND WHEEL	146	3/8"-2/1/2" SCREW
114	1/4" SET SCREW	147	CLAMP SHOE
115	C-RING	148	TRUNNION
116		149	SCREW
117	SPRING	150	3/8"-2" SCREW
118	M6 SET SCREW	151	3/8" WSHER
119	KNOB	152	TABLE BRACKET
120	GEAR	153	KNOB
121		154	3/16" SCREW
122		155	POINTER
123		156	SCALE
124	BLADE COVER	157	BRACKET
125	KNOB	158	GUIDE SHAFT(S)
126	1/4"-3/4" SCREW	159	SCREW
127	BRACKET		
128	BEARING SUPPORT BRACKET		
129	BEARING		
130	C-RING		
131	GUIDE SHAFT(L)		
132	SUPPORT		
133	1/4"-3/4" CAP ACREW		

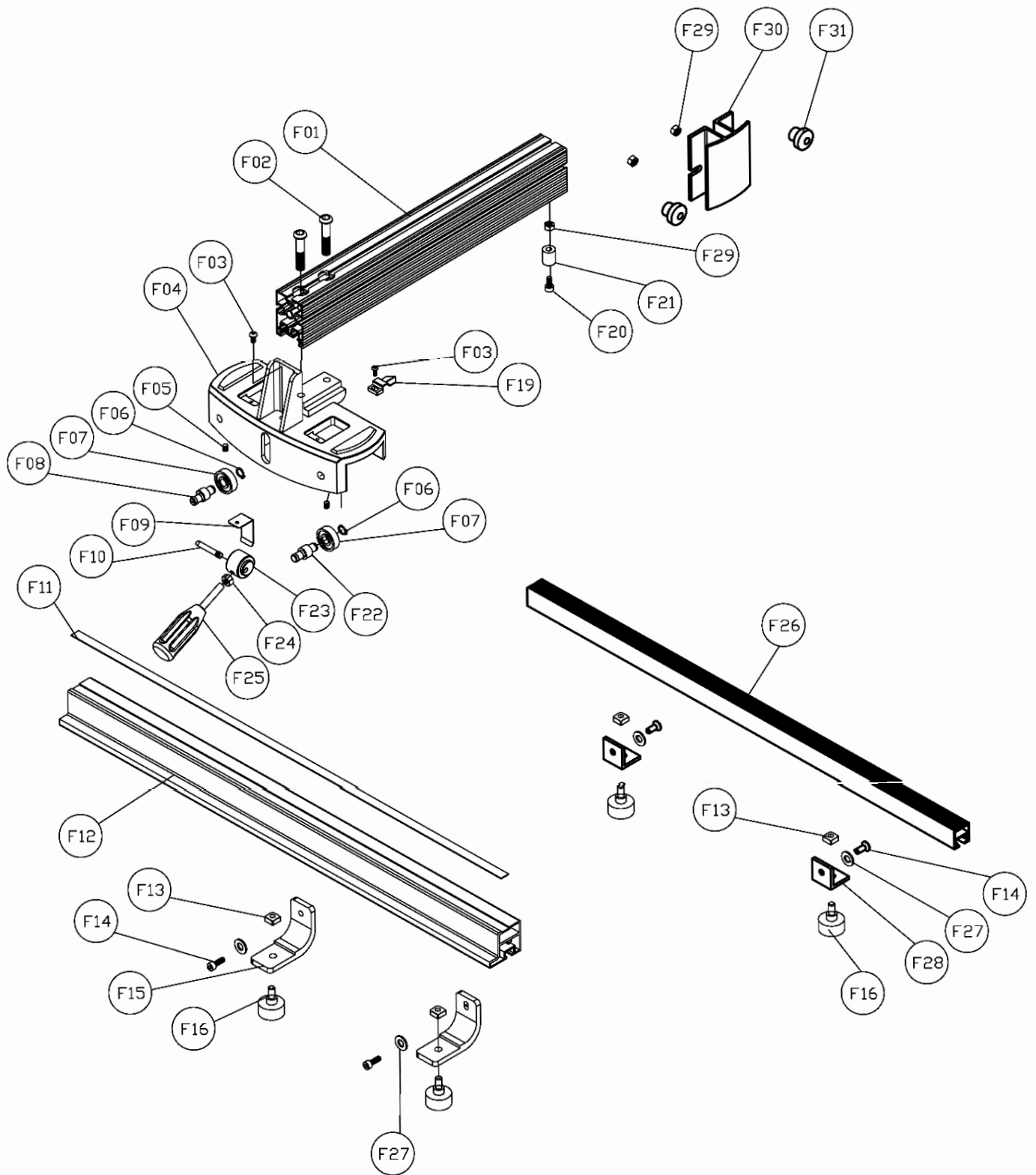

REF	DESCRIPTION
F01	FENCE BODY
F02	CAP SCREW 10*16
F03	BUTTON HEAD SCREW 5*10MM
F04	FENCE BASE
F05	SET SCREW 1/4"*1/4"
F06	EXTERNAL RETAINING RING S10
F07	BEARING
F08	ECCENTRIC SHAFT
F09	PRESSURE PLATE
F10	PIN
F11	SCALE
F12	FENCE RAIL FRONT
F13	SQUARE NUT 5/16
F14	CAP SCREW
F15	L TYPE PLATE
F16	KNOB 5/16*5/8
F17	
F18	
F19	POINTER
F20	HEX BOLT 1/4"*3/4"
F21	RUNNER
F22	BEARING SHAFT
F23	LOCK MECHANISM
F24	HEX BOLT 8MM
F25	FENCE HANDLE
F26	REAR RAIL
F27	FLAT WASHER 1/4"
F28	L BRACKET
F29	HEX NUT 1/4"
F30	Resaw attachment
F31	knob 1/4"*3/8"





# Warranty and Service

Oliver makes every effort possible to assure that its equipment meets the highest possible standards of quality and durability. All products sold by Oliver are warranted to the original customer to be free from defects for a period of 2 (two) years on all parts, excluding electronics and motors, which are warranted for 1 year. Oliver's obligation under this warranty shall be exclusively limited to repairing or replacing (at Oliver's option) products which are determined by Oliver to be defective upon delivery F.O.B. (return freight paid by customer) to Oliver, and on inspection by Oliver. This warranty does not apply to defects due, directly or indirectly, to misuse, abuse, negligence, accidents, unauthorized repairs, alterations, lack of maintenance, acts of nature, or items that would normally be consumed or require replacement due to normal wear. In no event shall Oliver be liable for death, personal or property injury, or damages arising from the use of its products.



Oliver Machinery is always adding new Industrial Woodworking products to the line.

For complete, up-to-date product information, visit us online at:

[WWW.OLIVERMACHINERY.NET](http://WWW.OLIVERMACHINERY.NET)

or call toll free 1-800-559-5065

**\*\* SAVE THIS MANUAL FOR FUTURE REFERENCES. \*\***