

# M15

# OPERATION MANUAL

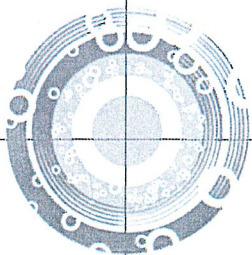

**TABLE OF CONTENTS**

**OPERATION OVERVIEW AND GENERAL INTRODUCTION ..... 1**

**INTRODUCTION ..... 2**

**MANUAL MODE ..... 3**

**SINGLE MODE ..... 3**

**PRE-SET PROGRAM (10 SETS)..... 4**

**PROGRAM LOCK AND OPEN(10 SETS) ..... 5**

**FAST PROGRAM..... 6**

**FINE ADJUSTMENT ..... 6**

**LOAD DATUM VALUES..... 7**

**SELECT COUNTING DIRECTION(+/-) ..... 8**

**RESOLUTION ..... 9**

**SENSOR CALIBRATION ..... 10**

**SET PARAMETER ..... 11**

**PARAMETER ..... 12**

**PARAMETER LOCK AND OPEN ..... 13**

**TROUBLESHOOTING ..... 14**

**INSTALLATION GUIDE ..... 16**

**POWER SUPPLY & HARDWARE ..... 18**

**EXTERNAL DIMENSION ..... 19**

## Operation Panel

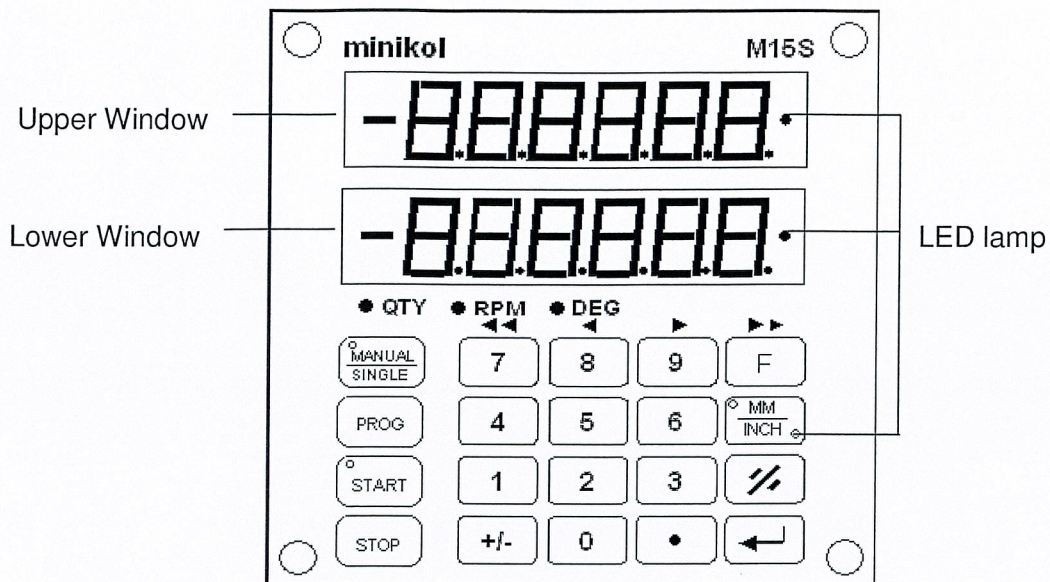

LED / KEY	Description	KEY	Description	KEY	Description
Upper Window	Target value		Manual / Single mode		Parameter
Upper LED	Target value LED		Program		mm / inch
Lower Window	Current value		Active		Clear / Return
Lower LED	Current value LED		Stop / Cancel		Confirm / Enter
0 ~ 9	Number keys		+ / -		Decimal

Note: Display : LED on / blinks

## Introduction

### Function:

- |                                    |                                       |
|------------------------------------|---------------------------------------|
| 1. One or two speed positioning    | 7. Resolution: 0.1mm/ 0.05mm/ 0.01mm  |
| 2. Manual / Single mode            | 8. Correct zero point                 |
| 3. 10 sets single program          | 9. Display: RPM speed                 |
| 4. 10 sets tool offsets            | 10. Protection for tool / motor fault |
| 5. Quick program / Fine Adjustment | 11. Battery life 2.5 year             |
| 6. Inch / mm conversion            | 12. Self-diagnose                     |

### Specification:

1	Housing:	115w × 115h × 80d (mm)
2	Panel cut out:	93w × 67h (mm)
3	Mounting screws:	M3 × 4 104 × 104 (mm)
4	Supply voltage:	24VDC/50mA/, C type battery (1.5V) × 1
5	Battery voltage control:	Low battery alarm
6	Sensor cable length:	3m
7	Thermal expansion:	$\alpha = 16 \times 10^{-6} \times 1/K$
8	Gap sensor/strip:	max. 2.5mm
9	Display:	15mm LED × 6 digits × 2 line
10	Output:	4 digital output (AC250V / 7A;DC24V/10A )
11	Input:	4 digital input ( 24VDC )
12	Operating elements:	20 button keyboard
13	Test mark/ interfere Protection class:	3 accord. to IEC 801
14	Travel Speed:	1.5m/s
15	System accuracy:	$\pm (0.025+0.02L)$ mm, L: Meter )
16	Repeatability:	0.01mm
17	Temperature:	Operating temperature 0 + 50, Storage temperature -20 +70°C
18	Humidity:	max. 95% rF(Condensation not permitted )

## Manual Mode

**Description:** To move the machine table by pressing M15 keyboard.

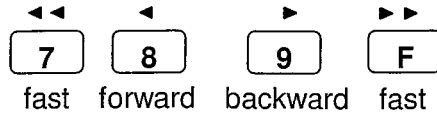

Example: M15 displays 100.00mm, to move the machine table:

※Note: Be sure in “**manual**” mode. (LED lamp of “manual / Single” key is blinking) The upper window shows “HAnd” mode.

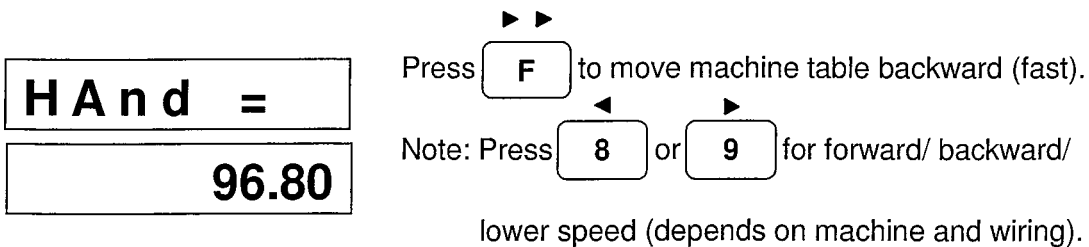
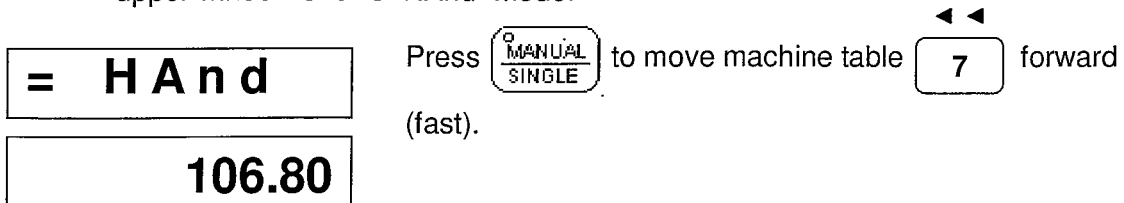

## Single Mode

**Description:** M15 can execute auto positioning.

Example: M15 current value is 100.00mm, to reach 200mm (setting target value).

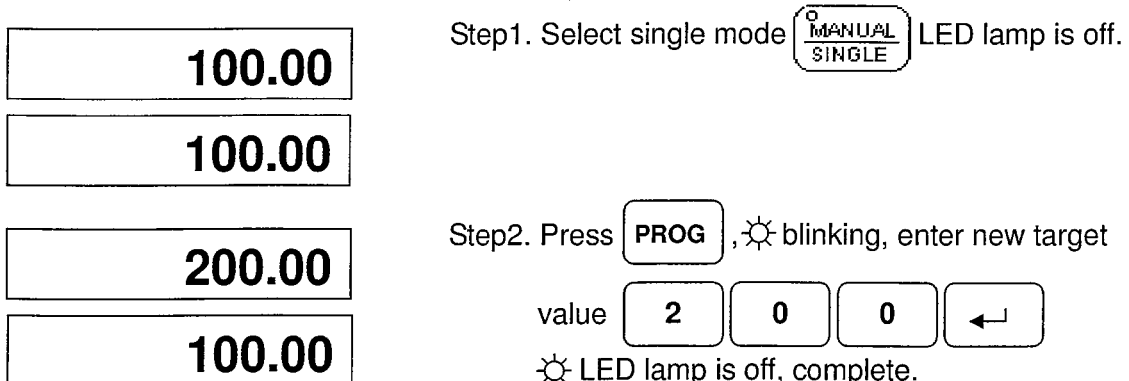





※Note: During positioning, press STOP to stop; to re-start, press PROG and ←

## Pre-Set Program (10 sets)

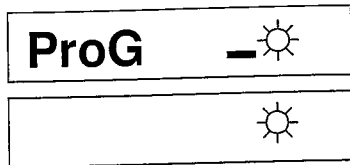
**Description:** Pre-set program 10 sets, enter program # 0~9 to execute.





Example: Program 1=10mm, Program 2=20.00mm.



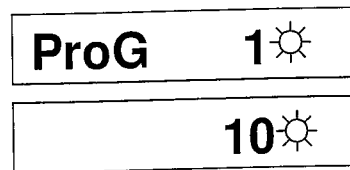

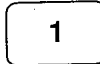
Step1. Press     select enter a key (0-9, total of 10sets).

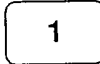
※Note: Be sure in manual mode.

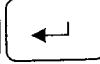

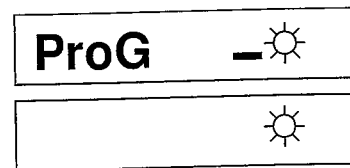
Step2. (Enter program 1=10mm), press    
more press   .



Step3. Target value display: ProG\_  at present,  
enter program 2=20.00mm, press  to  
exit.

## Program Open and Lock (10 sets)

**Description:** Don't needs pre-set program, to start or close.

Example: Program 1=10.00mm for  , program 2= 20.00mm for  ,  
 ~  other a key, don't setting pre-set program, to stop follow  
steps as below:

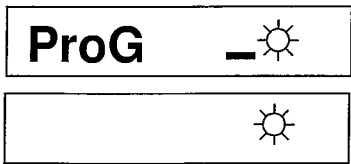

Step1. Press

target value display: ProG\_☀.

※Note: Be sure in single mode.

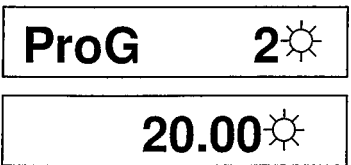

Step2. Press

current value display: \_\_\_\_\_,  closed,  
frame display,  started.

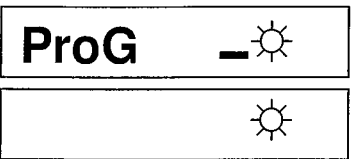



Step3. Press  to close

※Note: To close other keys, follow the step 2, 3.

## Fast Program

**Description:** To facilitate frequently used positions, the keys 0 to 9 have associated preset target values. And the positioning can be started immediately.

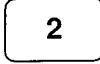
Example: Program 1=10.00mm, program 2=20.00mm. Execute program 2 as below:













100.00	Step1. Select single mode  LED lamp off.
100.00	
20.00	Step2. Press  target value display: 20.00mm  LED blinking, to waiting start.
100.00	

※Note: Execute program1 press#1.

## Fine Adjustment

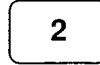
**Description:** Increase and decrease to reach fine adjustment.

Example: M15 target value display100.78mm, increase/ decrease target value0.25mm, setting steps as below:

0.00 	Step1. Increase target value: press  display 0.00  LED blinking, decrease: press  twice, display-0.00  LED blinking.
100.00	
0.25 	Step2. Press     press  to completed.
100.00 	

※Note: Target value display: 101.03mm, current value display:100.78mm for target value increase 0.25mm.



## Load datum values

**A. Description:** To load current value according to working piece.

Example: M15 current value display 100.00mm, actual size: 100.50mm, follow the steps as below:









100.00

100.00

Origin 

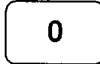
100.00 

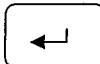

Step1. Select single mode  LED lamp off.

Step 2. Press    , enter new value, press      press  , to exit.

**B. How to show the new set value:**

F 0 

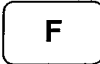
100.00

Step1. Press   , press  twice, display new value.

## Select Counting Direction(+/-)

**Description :** To select the counting direction.

Example : M-15 current value display: 100.00mm, sensor forward for decrease value 99.68mm, but hope value become big, value increase follow the steps as below:

100.00

99.68

F 1 ☀

99.68

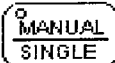
Step1. Press  back single mode, LED lamp off.

Step 2. Press   

target value display origin parameter value “-dir”  
(select counting direction parameter).

-dir

Step 3. Press  to select the direction, -dir / dir ☀  
(or“-dir” for left or “dir- ” for right.)

100.00

99.68

Step 4. Press  to complete, and exit.

## Resolution

**Description:** Select resolution: 0.1mm/0.01mm/0.05mm.

Example: M15 current value display 100.0mm, to select display: 100.00mm follow the steps as below:

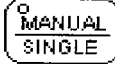

100.0

100.0

Step 1. Select single mode  LED lamp off.

F 90☀

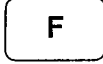
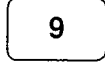
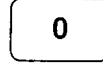
100.0☀

Step 2. Press     to select resolution.

rES ☀

0.01☀

Step 3. Press  /  (0.1 / 0.01 / 0.05)

100.00☀

100.00☀

Step 4. Press  to complete and exit.

## Sensor Calibration

A. **Description:** For better accuracy, please execute calibration immediately after installed sensor each time.

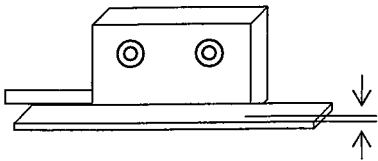

Gap sensor-tape

Step 1. Fix sensor, keep 1mm gap from tape  
**(RECOMMENDED).**

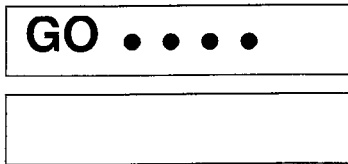

Step 2. Press **F** **9** **9** **←**  
Target value display GO●●●● (Enter parameter)

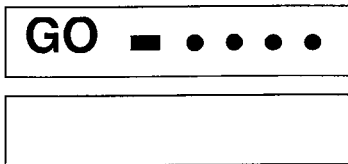

Step 3 · Press and hold **8** or **9** to start.

※Note : Moving the slider at low speed, Required distance around 120mm (Moving GO●●●●)

Display: **GO ■●■●●●** (Detecting)

Display: **GO ■●■●■●●●** (Almost complete)

When completed calibration, LED display will flash and show.

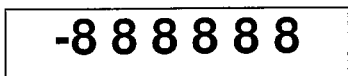

※Note: Please reload origin datum values refer to page8.

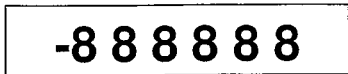

**B. Troubleshooting of calibration:**

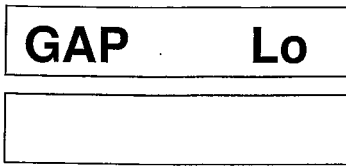

a. Display: GAP LO  
Possible cause: The gap is too narrow.  
Excluding: Please enlarge the gap. Press  and follow step 2 again.

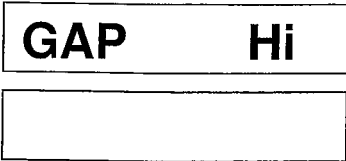

b. Display: GAP Hi  
Possible cause: The gap is too big.  
Excluding: Please narrows the gap and press  calibration again.

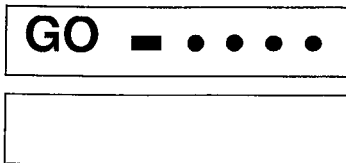

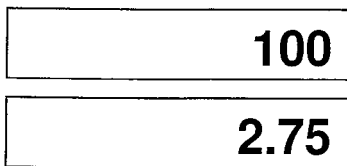

c. Display: GO●●●● or GO■●●●● or GO■●■●●●  
Possible cause: The gap too big or machine surface is not flat/smooth.  
Excluding: Adjust gap or improve the machine surface.

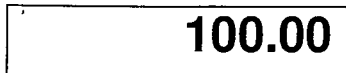

d. During calibration press  to exit.

**Set Parameter**



Step 1. Select single mode  LED lamp off.

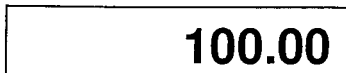

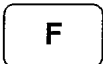
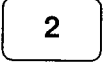
Step 2. Press  select enter parameter #, example parameter 2, press 

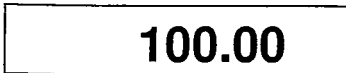
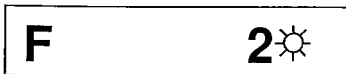

Step 3. Press  target value display OriGin(Lond parameter)



※Note: Refer to set parameter or page12.

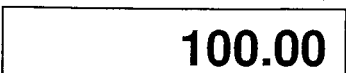

※Note: Press  to exit.

## Parameter

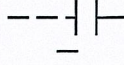
Parameter	Display	Description	Default	Remarks
0	<b>CHAnGE</b>	Load datum value	0	
1	<b>dir</b>	Select counting direction (+ / -)	-dir	
2	<b>OriGin</b>	Load origin	0.00mm	
3	<b>OffS-</b>	Set tool diameter	0.00mm	
4	<b>POSdir</b>	Positioning mode		
5	<b>SPEEd</b>	One or two speed positioning	1sp	
9	<b>LoAd 0</b>	Load tool diameter	0.00	
10	<b>Lo-End</b>	- Software limit	-50.00mm	
11	<b>Hi-End</b>	+ Software limit	1000.00m m	
15	<b>InPOS</b>	Positioning output time	0.15ms	
17	<b>toLL</b>	Tolerance	0.30mm	
19	<b>FAuLt</b>	Low speed limit	55	
20	<b>LinCOr</b>	Linear correction	1.00000	
30	<b>PASS</b>	Parameter lock	----	
33	<b>SOurCE</b>	Software version		
55	<b>PrOG-</b>	Fast program		
90	<b>rES</b>	Resolution	0.01mm	
99	<b>GO....</b>	Sensor calibration		

## Parameter Lock And Open

**Description:** Needless function can open or close, to prevent client operation unsuitable to cause the fault.

100.00

100.00

PASS 





dir 

on 

dir 

on 

Step 1. Select single mode  LED lamp off



Step 2. Press    

target value display "PASS"  blinking,

current value display: \_ \_ \_ \_  blinking

Step 3. Press    

into the on/off set parameter.

※Note: Press  or 

(dir/ OriGin/ FAULT/ inPos)

Step 4. Press  setting on/off

Example: Frame display "dir off" indicate  $\pm$ direction

parameter open.

Frame display: "dir on" indicate  $\pm$ direction

Parameter close.

Press  to setting and exit.

## Troubleshooting

**SEnSor**

**Error**

1. Possible Cause: No sensor

Excluding: a. Power off

b. 9 Pin connector is loosen or wire broken

c. The gap is too big between sensor and tape.

**CHAnGE**

**rst**

2. Possible Cause: A motion in the wrong direction.

Excluding: a. Power off b. Change R. S. T.

**EnGinE**

**FAuLt**

3. Possible Cause: a. Motor fault or overload.

b. Motor fault investigate setting

wrong (F19)

c. External limit action

Excluding: a. Press 

b. Check parameter F19

c. Power off

d. Check external limit

e. Check motor and control line

**100.00** ☀

**100.00**

4. Possible Cause: a. Over soft limit

b. Target value setting wrong

c. Parameter value setting wrong

Excluding: Press 



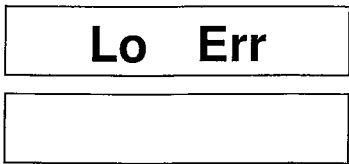



5. Possible Cause: Current value over soft low and high  
(F10、F11)

※Note: Frame show Lo/Hi

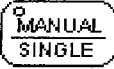
Excluding: a. Check machine table whether over the travel.

b. Press  LED blinking  
press  or  to exit.

c. Please reload origin datum values refer to page8.



6. Possible Cause: Indicates battery discharged

Excluding: a. Power off

b. Change the battery(1.5V \* 1 tape)

c. Turn the power on again

d. Please reload origin datum values refer to page8.(If current value lose)

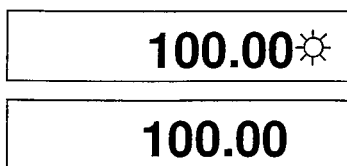

7. Possible Cause: Waiting for enter target value

Excluding: a. Enter new target value

b. Press  to exit

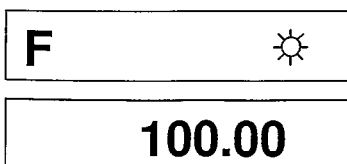

8. Possible Cause: In the parameter setting value

※Note: Frame show F/origin

Excluding: Press 

## **Installation Guide**

\* The magnetic tape consists of three components:

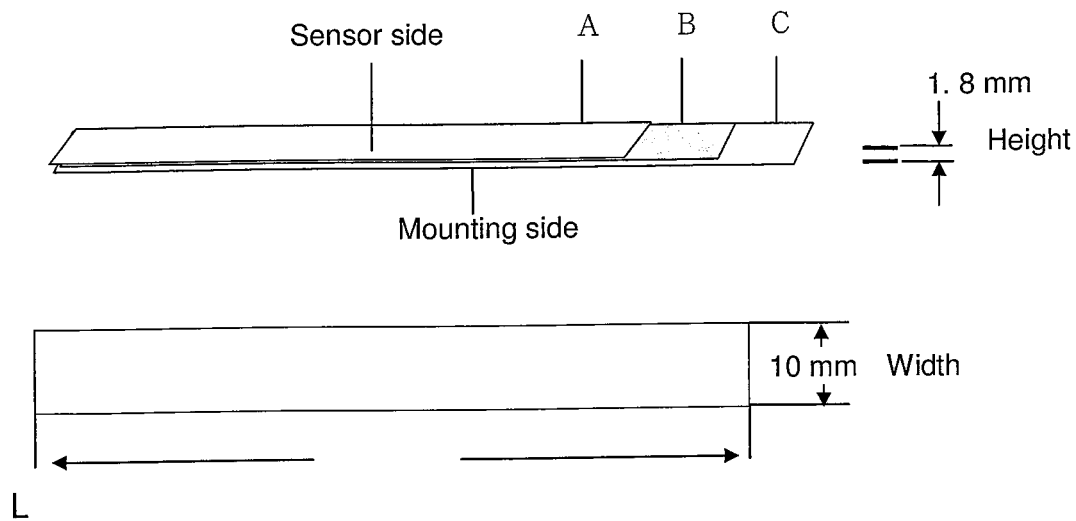

A. A magnetized, highly flexible synthetic tape.

B. Flexible steel tape. A and B are already factory-bonded.

C. To keep the flexibility for transport and installation, the third part, also a steel tape is delivered separately. It serves for mechanical protection of the synthetic tape and must be stuck on the magnetic synthetic tape after installation.

### **Installation:**

- a. There components of tape: depth:1.8mm, width:10mm.
- b. Ensure to apply tape on clean, dry and plain surface.
- c. Be sure the tape adhesion on surface.
- d. Please apply the tape with ambient temperature: 21~38°C
- e. We recommend to make a chamfer on the machine to install the tape.
- f. If cut a edge can stable the tape.

**Cable:**

- Distance more than diameter 50mm.
- Must be away from inductive and capacitive interference source as conductor, relays, motors, switch power pack clocked controllers, etc
- Must be kept a distance to interference sources.

**Sensor:**

- Allow some fault when install the sensor.
- Attend the position when install the sensor.

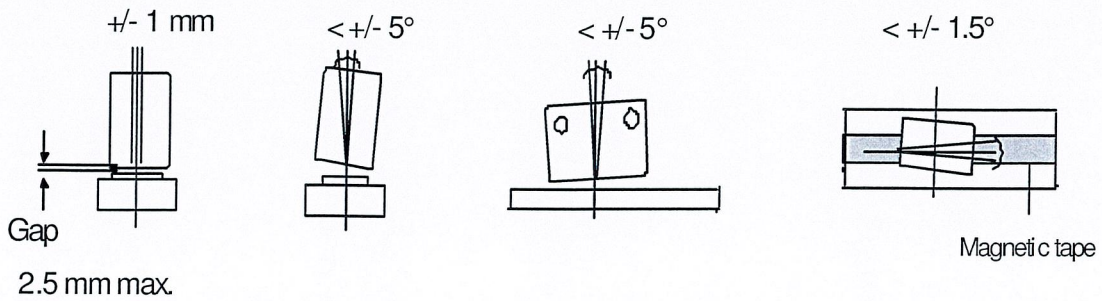

Recommend Gap between tape and sensor: 1mm

Unit: mm

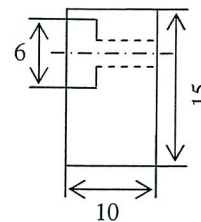
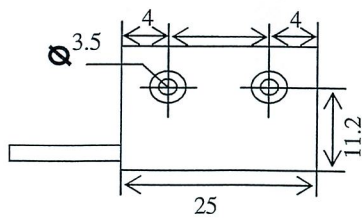
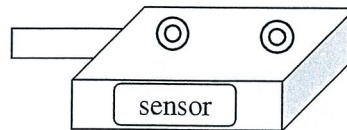
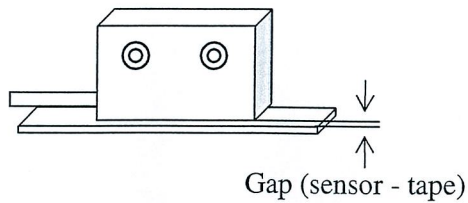

## Power Supply & Hardware

Power supply: a. 2 PIN connector

b. DC 18 ~ 30V 50mA

Battery: C type battery×1, the battery life: 2.5 year(24hr)

Output: a. 8 pin connector

b. Relay × 4: Forward Reverse Low speed Positioning.

Note: Positioning only works inside the tolerance and on position mode.

Manual mode: Do not work.

c. NO

d. AC240V/ 5A AC120V/ 10A DC24V/ 10A

Input: a. 5 Pin connector

b. DC 24V

c. NPN or PNP

d. 10mA

- COM
- Start
- Stop
- Repeat
- No use

Sensor : 9 pin connector

### Back panel(face squarely)

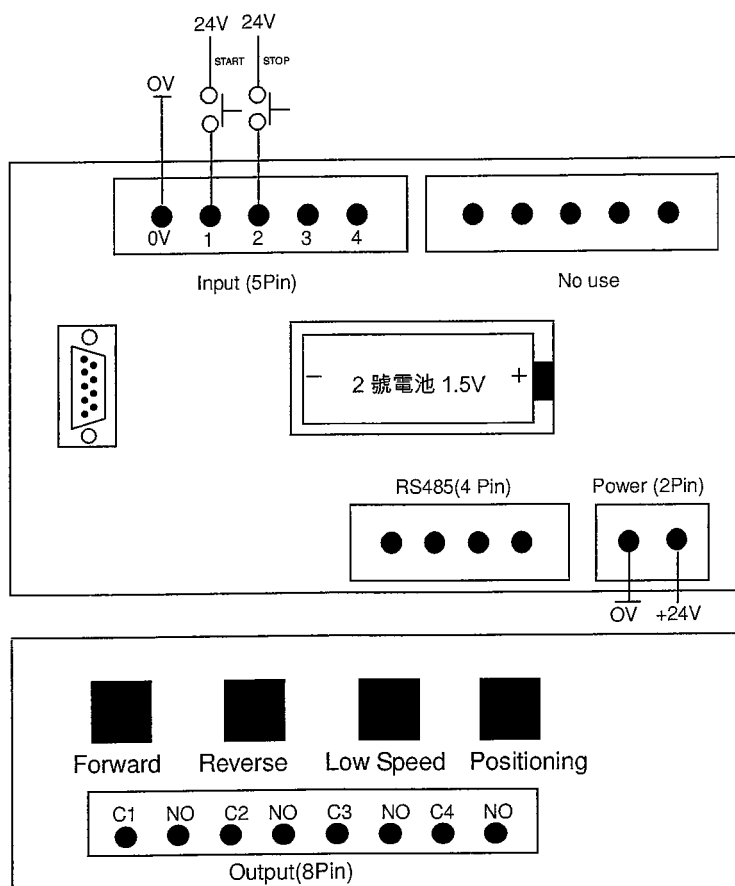

## External Dimension

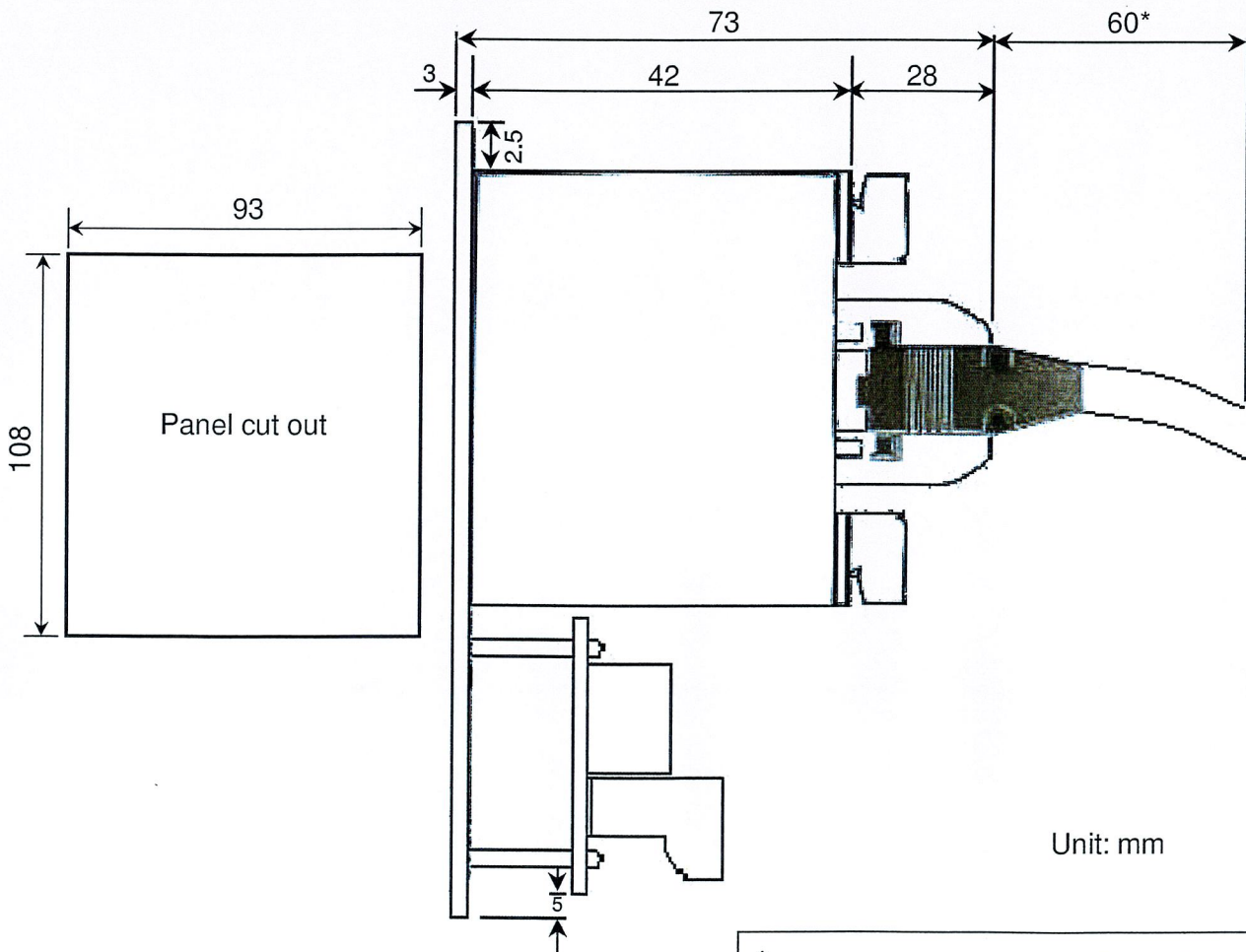
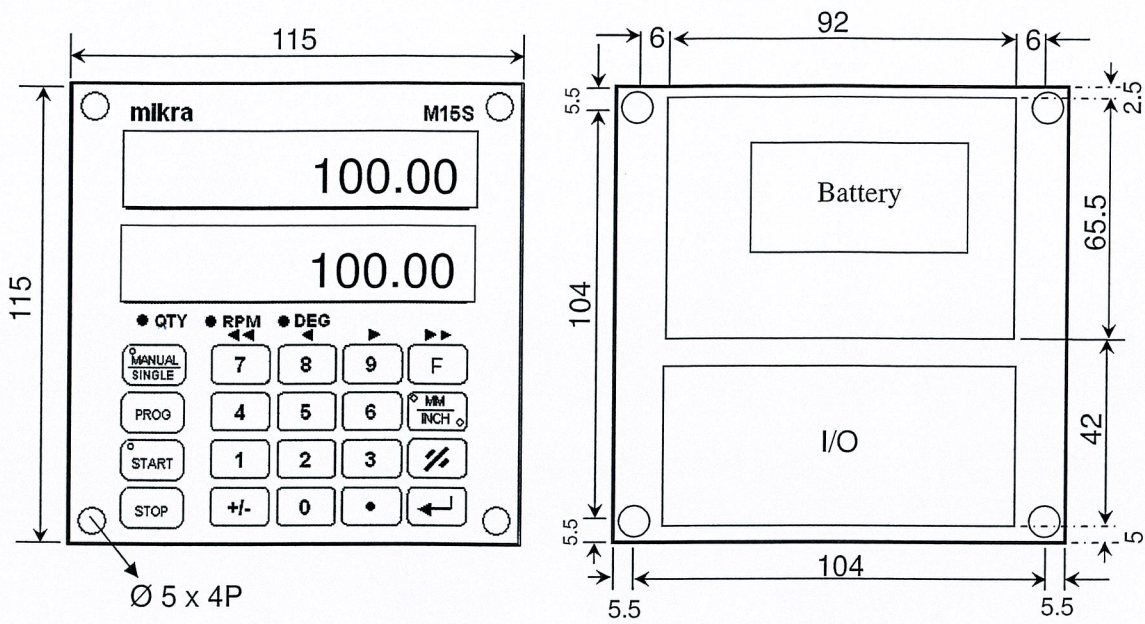

Unit: mm

\*: Required extra space for installation: 60mm