



# 4230 8" Jointer

## Owner's Manual



## **Warranty**

Oliver makes every effort possible to assure that its equipment meets the highest possible standards of quality and durability. All products sold by Oliver are warranted to the original customer to be free from defects for a period of 2 (two) years on all parts, excluding electronics and motors, which are warranted for 1 year. Oliver's obligation under this warranty shall be exclusively limited to repairing or replacing (at Oliver's option) products which are determined by Oliver to be defective upon delivery F.O.B. (return freight paid by customer) to Oliver, and on inspection by Oliver. This warranty does not apply to defects due, directly or indirectly, to misuse, abuse, negligence, accidents, unauthorized repairs, alterations, lack of maintenance, acts of nature, or items that would normally be consumed or require replacement due to normal wear. In no event shall Oliver be liable for death, personal or property injury, or damages arising from the use of its products.

## **Warning**

Read this manual thoroughly before operating the machine. Oliver Machinery disclaims any liability for machines that have been altered or abused. Oliver Machinery reserves the right to effect at any time, without prior notice, those alterations to parts, fittings, and accessory equipment which they may deem necessary for any reason whatsoever.

## **For More Information**

Oliver Machinery is always adding new Industrial Woodworking products to the line. For complete, up-to-date product information, check with your local Oliver Machinery distributor, or visit [www.olivermachinery.net](http://www.olivermachinery.net)

# WARNING

Read this manual completely and observe all warning labels on the machine. Oliver Machinery has made every attempt to provide a safe, reliable, easy-to-use piece of machinery. Safety, however, is ultimately the responsibility of the individual machine operator. As with any piece of machinery, the operator must exercise caution, patience, and common sense to safely run the machine. Before operating this product, become familiar with the safety rules in the following sections.

- **Always keep guards in place and in proper operating condition.**
  - **Never reach around or under the jointer.**
1. **If you are not properly trained** in the use of a jointer do not use until the proper training has been obtained.
  2. **Read, understand and follow** the safety instructions found in this manual. Know the limitations and hazards associated with this machine.
  3. **Electrical grounding:** Make certain that the machine frame is electrically grounded and that a ground lead is included in the incoming electrical service. In cases where a cord and plug are used, make certain that the grounding plug connects to a suitable ground. Follow the grounding procedure indicated in the National Electrical Code.
  4. **Eye safety:** Wear an approved safety shield, goggles, or glasses to protect eyes. Common eyeglasses are only impact-resistant, they are not safety glasses.
  5. **Personal protection:** Before operating the machine, remove tie, rings, watch and other jewelry and roll up sleeves above the elbows. Remove all loose outer clothing and confine long hair. Protective type footwear should be used. Where the noise exceeds the level of exposure allowed in Section 1910.95 of the OSHA Regulations, use hearing protective devices. Do not wear gloves.
  6. **Guards:** Keep the machine guards in place for every operation for which they can be used. If any guards are removed for maintenance, DO NOT OPERATE the machine until the guards are reinstalled.
  7. **Work area:** Keep the floor around the machine clean and free of scrap material, saw dust, oil and other liquids to minimize the danger of tripping or slipping. Be sure the table is free of all scrap, foreign material and tools before starting to use the machine. Make certain the work area is well lighted and that a proper exhaust system is used to minimize dust. Use anti-skid floor strips on the floor area where the operator normally stands and mark off machine work area. Provide adequate work space around the machine.
  8. **Jointer position:** Position the jointer so that in case of material kick back the flying piece will not injure workers.
  9. **Material condition:** Do not attempt to joint boards with loose knots or with nails or other foreign material.
  10. **Operator:** Always use push blocks. Maintain a balanced stance and keep your body under control at all times.
  11. **Before starting:** Before turning on machine, remove all extra equipment such as keys, wrenches, scraps, and cleaning rags away from the machine and off the table.

12. **Careless acts:** Give the work you are doing your undivided attention. Looking around, carrying on a conversation, and “horseplay” are careless acts that can result in serious injury.
13. **Disconnect all power sources:** Before performing any service, maintenance, adjustments or when changing blades. A machine under repair should be RED TAGGED to show it should not be used until the maintenance is complete.
14. **Job completion:** If the operator leaves the machine area for any reason, the jointer should be turned "off" and the cutter head should come to a complete stop before leaving.
15. **Replacement parts:** Use only genuine Oliver Machinery factory authorized replacement parts and accessories; otherwise the warranty and guarantee are null and void.
16. **Misuse:** Do not use this Oliver jointer for other than its intended use. If used for other purposes, Oliver disclaims any real or implied warranty and holds itself harmless for any injury or damage which may result from that use.
17. **Drugs, alcohol and medication:** Do not operate this machine while under the influence of drugs, alcohol, or any medication.
18. **This machine is designed** for planing wood products only. Do not use to cut any kind of metal or substance other than wood.
19. **Never start the jointer** while a workpiece is in contact with the blade.
20. **Raise or lower the tables** only when the machine has been turned “off” and the cutter head has come to a complete stop.
21. **Make sure** the cutter head is running in the proper direction. The knives should be turning toward the infeed table.
22. **Health hazards:** Some dust created by power sanding, sawing, grinding, drilling and other construction activities contains chemicals known to cause cancer, birth defects or other reproductive harm. Some examples of these chemicals are:
  - Lead from lead-based paint.
  - Crystalline silica from bricks and cement and other masonry products.
  - Arsenic and chromium from chemically-treated lumber.Your risk from these exposures varies, depending on how often you do this type of work. To reduce your exposure to these chemicals, work in a well-ventilated area, and work with approved safety equipment, such as those dust masks that are specifically designed to filter out microscopic particles.

Familiarize yourself with the following safety notices used in this manual:

**CAUTION:** (This means that if precautions are not heeded, it may result in minor or moderate injury and/or possible machine damage)

**WARNING:** (This means that if precautions are not heeded, it could result in serious injury or possibly even death).

<b>Table of Contents</b>	<b>Page Number</b>
Warranty.....	2
Warnings.....	3-4
Table of Contents.....	5
Specifications.....	5
Uncrating the Machine.....	6
Contents.....	6
<b>Machine Preparation and Setup</b> .....	<b>6-8</b>
Control panel and magnetic starter.....	7
V-Belts.....	7
Handwheels.....	8
Dust Collection.....	8
Electrical Connections.....	8
Blade guard.....	8
<b>Fence Operation</b> .....	<b>9</b>
Fence Legend.....	9
Adjustment of the 90 Degree Stop.....	9
Fence Operation.....	9
<b>Knives</b> .....	<b>10</b>
Knife Replacement.....	10
Adjusting the Outfeed Table.....	10
<b>Operation</b> .....	<b>11</b>
Hand Safety and Placement.....	11
Jointing.....	11
Direction of the grain.....	11
Edging.....	11
Facing.....	12
Beveling.....	12
Rabbeting.....	12
Adjusting the Infeed Table Height.....	13
<b>Maintenance</b> .....	<b>13</b>
V-Belts.....	13
Lubrication.....	13
Knives.....	13
Table Leveling.....	13
<b>Troubleshooting</b> .....	<b>14</b>
<b>Specifications</b>	
Model No.....	4230
Motor.....	.2HP, 1PH, 220 Volt
Full load amps.....	12
Infeed Table Travel (in.).....	1/2
Cutterhead speed (RPM).....	5500
Number of Knives.....	54
Rabbeting Capacity (in.).....	1/2
Dust Port Diameter (in.).....	4
Table Dimensions (L x W/in.).....	74-7/8 x 9-1/4
Table Height (In.).....	30-1/2
Fence Dimensions (L x H/in.).....	38 x 4
Fence Tilts (deg.).....	90 - 45
Positive Stops (deg.).....	90 and 45
Overall Dimensions.....	75 x 25 x 40
Gross Weight (lbs.).....	572
CFM.....	440CFM at 4500FPM air velocity

## Oliver 4230 – 8” Jointer

### Uncrating the Machine

The machine should arrive as show in Figure 1. Uncrate the machine and inspect the unit for signs of shipping damage. If damage is found, contact your dealer immediately. Unbolt the machine from the pallet. Retain all packaging materials in case it becomes necessary to ship the machine to another site.

### Contents: (Figure 2)

1. Blade guard
2. Two in/outfeed table hand wheels
3. Two speed handles for hand wheels
4. Two V-belts
5. Two push handles
6. Dust collection flange
7. Fence width adjustment knob
8. Two torx screw drivers, extra knives and screws.
9. Tools; three wrenches and two allen keys.
10. Three hardware packets.
11. Jointer to stand mounting bolts.

### Machine Preparation and Setup

#### **WARNING!**

**The equipment used to lift this machine must have a rated capacity at, or above the weight of the jointer. Failure to comply may cause serious injury!**

Mount the jointer top to the stand as seen in Figure 3. Line up the holes then lower the jointer onto the stand. Use the three, jointer to stand mounting bolts (#11 of Figure 2), to secure the jointer to the stand. The jointer must be positioned on a smooth, level surface. The area must be well lit and have plenty of room to maneuver with large pieces of wood.

Level the jointer front to back and side to side using a level placed on the table. Adjust the leveling feet as needed but make sure the jointer is stable before being placed into service.

Clean all rust protected surfaces with a commercial solvent. Do not use acetone, gasoline, lacquer thinner or any type of flammable solvent, or a cleaner that may damage paint. Cover cleaned surfaces with WD-40 or a 20W machine oil.

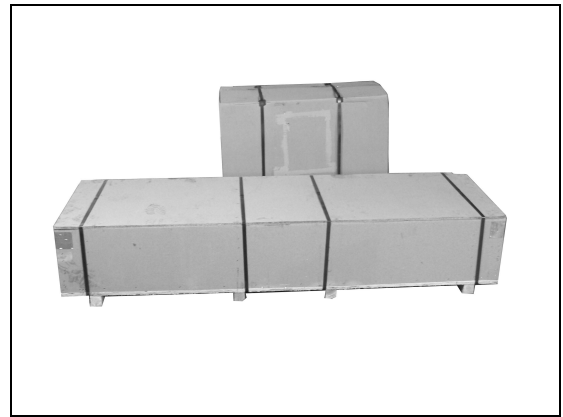

Figure 1

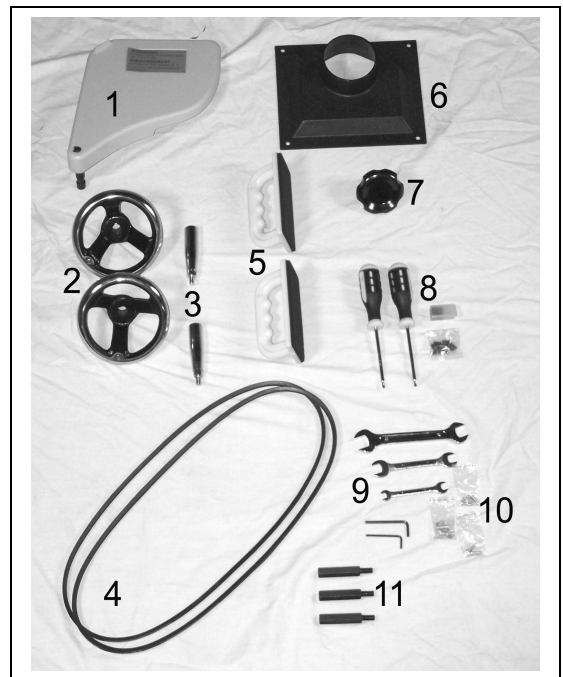

Figure 2



Figure 3

## Machine Preparation and Setup (Cont.)

### Control Panel and Magnetic Starter

Remove the control box and magnetic starter from the jointer stand. Mount the control box to the back of the stand as shown in Figure 4 using the supplied 12mm hex bolts.

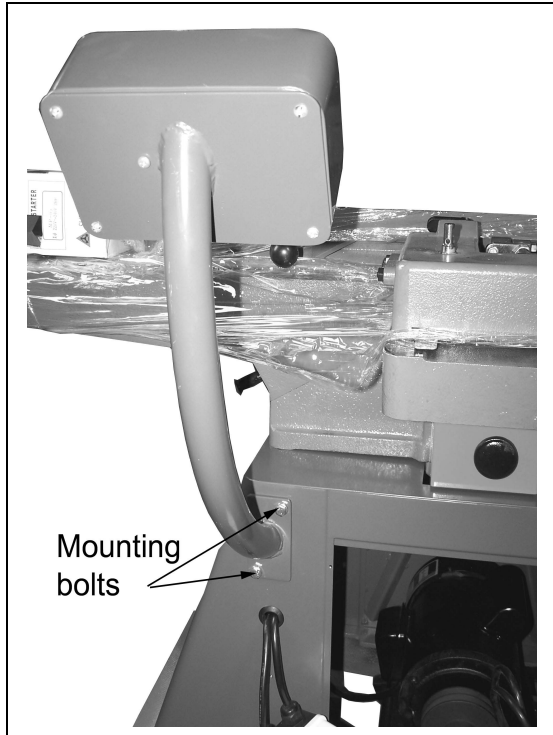

Figure 4

Remove the lid from the magnetic starter and mount the switch to the back of the jointer stand using the two machine screws as shown in Figure 5. Insert the screws through the two large threaded holes in which the large plastic screws secure the cover. Once in place, re-install the lid.

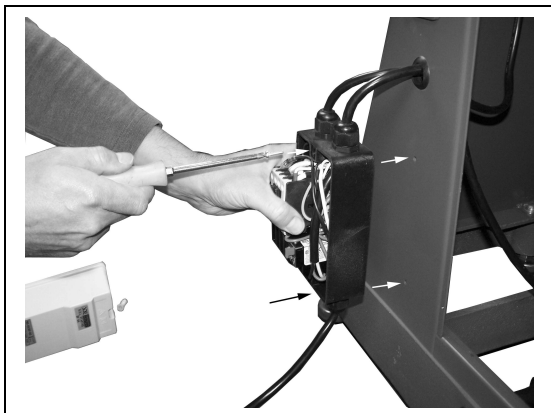

Figure 5

### V-Belts

Remove the belt guard and set aside as shown in Figure 6. Place the belts over the cutterhead and motor pulley. It may be necessary to loosen the nuts of the belt tension rods in order to stretch the belts over the pulleys. Once in place adjust the nuts of the belt tension rods to give approximately 1/2" deflection midway along the belts using finger pressure. Re-install the belt guard.

After approximately 20 hours of operation re-check the tension on the belts and adjust if necessary.

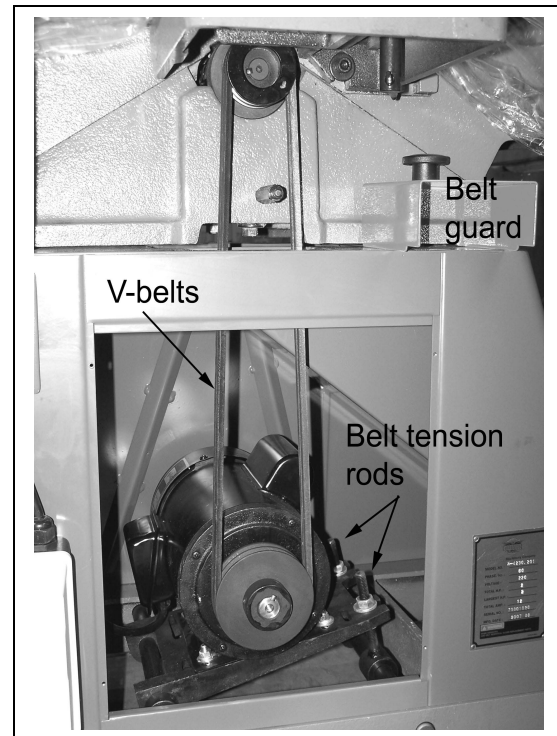

Figure 6

## Handwheel Installation (Figure 4)

The jointer comes with two hand wheels with speed handles (#'s 2 & 3 of Figure 2). The speed handle #2 screws into the threaded hole of the hand wheel and the assemblies slide onto the raising and lowering shafts of both the infeed table and outfeed table. The mounting screws and washers and keys are shipped, mounted on the shafts. Remove the tape securing the keyway and remove the screw and washer from the end of the shaft. Slide the hand wheel over the shaft and key then secure in place with the screw and washer. Do the same for both tables.



Figure 4

## Dust Collection

The 4230 is supplied with a mountable 4" dust port. If using a dust collector mount the dust port as shown in Figure 5. Secure it in place, under the outfeed table, with the supplied machine screws.



Figure 5

## Electrical Connections

The jointer comes supplied with its own power cord therefore the only electrical connection required is to add a plug to the end of the cord. The jointer is rated at 12amp at 220 volt therefore install a plug rated to handle this

amperage and one that will match your receptacle.

## Blade Guard Installation

Insert the shaft of the blade guard into the hole as shown in Figure 6. The lock screw should line up with the divet of the shaft. Before tightening the screw lift the fence and lock it into place. Push the blade guard so it is underneath the fence (Figure 7) and the horizontal roll pin at the top of the guard shaft rests against the side of the infeed table. Lock the guard into place with the lock screw. Pull the guard back and lower the fence. Check for adequate spring return action of the blade guard.

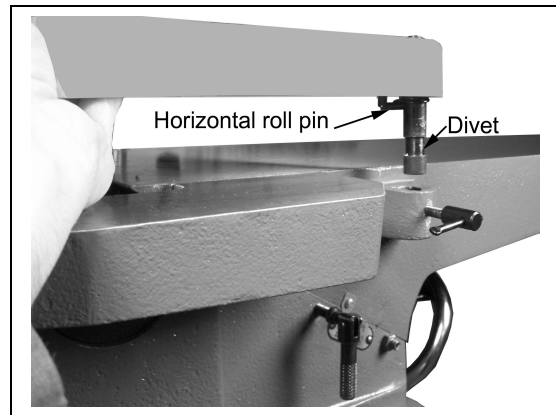

Figure 6

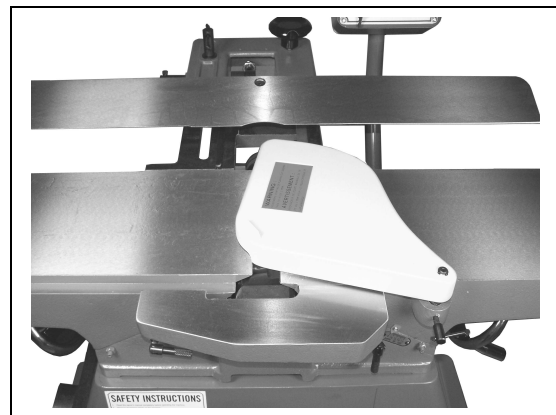

Figure 7



## Fence Operation

### **WARNING!**

Never make any adjustments with the machine running!

### Fence Legend

The various adjustments, locks and handles are shown in Figure 8.

90 degree adjustment

90 degree flip stop.

Angle lock handle.

45 degree adjustment.

Width lock handle.

Fence width lock.

### Adjustment of the 90 Degree Stop

1. Lay a square on the infeed table as shown in Figure 9.
2. Loosen the angle lock handle (F, Figure 8).
3. Ensure the 90 degree flip stop (B, Figure 8) is in the 90 degree position as shown.
4. Loosen the jam nut on the 90 degree adjusting bolt (A, Figure 8) and adjust the bolt against the flip stop until the fence becomes true with the square.
5. Tighten the jam nut while holding the bolt in position.

### Fence Operation

To tilt the fence, see Figure 8. Loosen angle lock handle 'C', flip up the stop 'B', and tilt the fence to the desired angle. Use a protractor or adjustable triangle to set the angle. A 45 degree stop, 'D' is provided for quick set-up at this angle.

To adjust the cutting width loosen the lock handle 'F' and move the fence to the desired position.

Once any adjustments are made be sure to lock them into place before jointing.

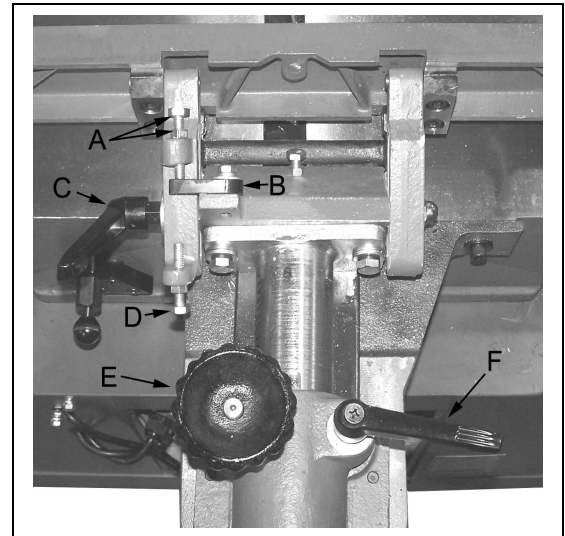

Figure 8

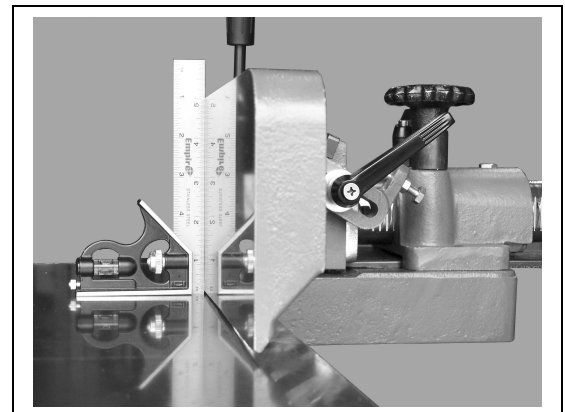

Figure 9

## Knives

### **WARNING!**

**The knives are extremely sharp. Use caution when handling.**

### Knife Replacement

If a knife gets nicked or dull, it can be rotated. Simply remove the torx screw with the provided driver as shown in Figure 10. Before rotating the knife it is extremely important to clean the pocket of any dust or debris as well as the underside of the knife. Any foreign material between the knife and pocket can cause knife breakage or leave excessive knife marks on the work piece.

To properly align the insert, hold the insert away from the seat while tightening to approximately 45-55 in/lbs torque. This allows the countersink in the tip and the taper of the head on the flat head screw to slide the tip into its proper position. If you do not have a torque driver, just understand that over tightening the knife can cause it to break .

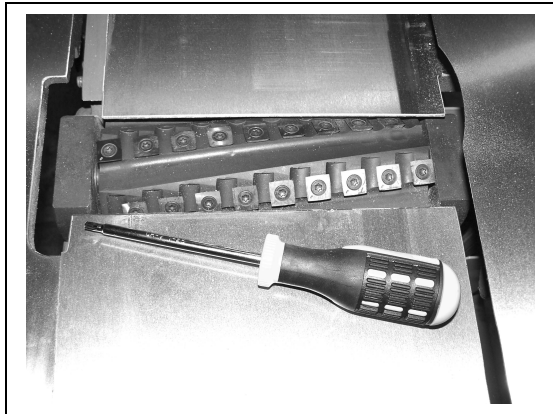

Figure 10

### Adjusting the Outfeed Table

1. For proper operation the height of the outfeed table must be set to the highest point of the cutting circle. To do this, set a straight edge on the outfeed table as shown in Figure 13.

2. Carefully adjust the table height by turning the handwheel (A, Figure 14) while rocking the cutterhead back and forth as shown by the arrow in Figure 13. The table will be at its correct height when the knife, at its highest point of the cutting circle, just scrapes the bottom of the straight edge.

3. Once set, lock into place with the height lock knob (B, Figure 14).

**Note:** Failure to adjust the outfeed table will result in either a curved or sniped work piece.

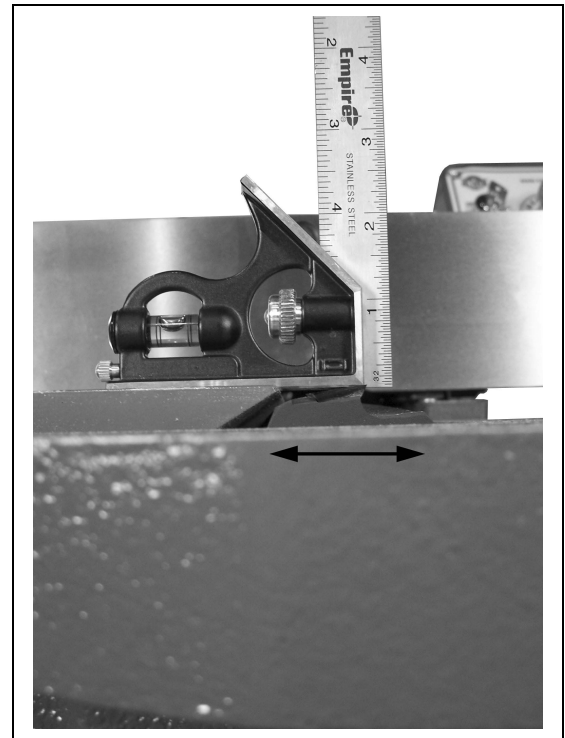

Figure 13

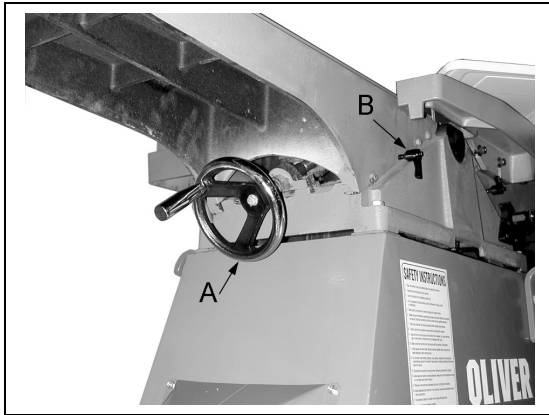

Figure 14

### Direction of the Grain

To avoid tear out, always feed the material in the direction of the grain. If the direction of the grain changes half way through the board, try taking lighter cuts at a slower feed rate. If the results are still unsatisfactory, try turning the material around and feeding the other way. (Figure 22)

### Edging

To give a good straight edge for gluing or joining, set the fence square with the table. Remove the least amount of material required to obtain a straight edge. Hold the best face of the piece firmly against the fence throughout the feed. When finished you will have a perfect starting point for your project. (Figure 23)

### Operation

#### **WARNING!**

**Keep all guards in place. Keep hands away from the cutterhead! Always use push stick when possible. Failure to comply may cause serious injury.**

#### Hand Safety and Placement

Never pass the hands directly over the cutter knife. As one hand approaches the knives remove it from the stock in an arc motion and place it back on the stock in a position beyond the cutter knife. See Figure 21.

When feeding the work piece, pressure is applied not only toward the cutterhead but against the fence and down to the table as well. At the start of the cut, the left hand holds the material down and toward the fence while the right hand pushes toward the cutterhead. As the material crosses the cutterhead the left hand comes up and over as in Figure 21 to continue the pressure but now on the outfeed table. As the right hand approaches the cutterhead it is time to move it up and over the cutterhead in the same fashion as the left in Figure 21 all the while continuing pressure as stated above.

### Jointing

In order to craft a good woodworking project, it is necessary to have a square piece of wood to start with. The way to do this is with a jointer. You need one straight edge and one flat face. After you have these, you can plane to thickness and rip to width and the resulting piece will be square and true on all four sides. At this point you can begin building your project.

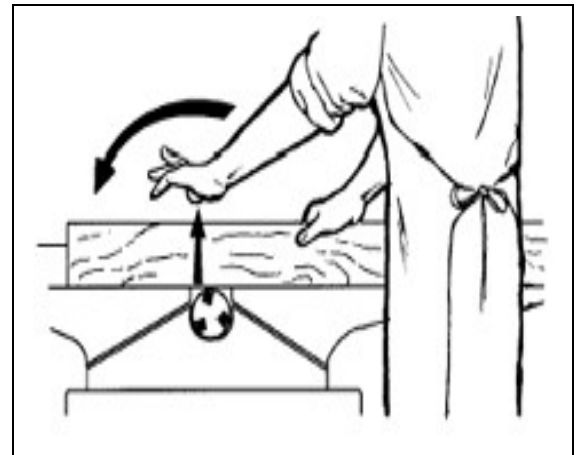

Figure 21

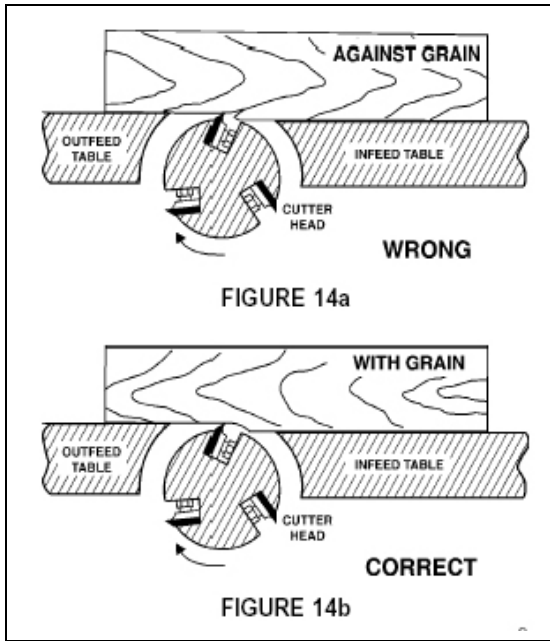

Figure 22



Figure 23

## Facing

Once you have a good edge it is time to eliminate any warp or cup on the board. Keep in mind the outfeed table is the reference point and once the material is past the cutterhead, downward pressure should be applied to the outfeed table only. Putting downward pressure on the board over the infeed table will bend any cup or warp prior to hitting the cutterhead and after the pressure is released, the cup will spring back. At the same time try keeping a constant feed rate in order to give a good smooth cut with no burn marks. (Figure 24)



Figure 24

## Beveling

For beveling (Figure 25), set the fence to the desired angle using a protractor and lock into place. Feed the material through pressing firmly against the fence and tables. Several passes may be necessary for the desired result.



Figure 25

## Rabbeting

### **WARNING!**

**Rabbeting requires removal of the blade guard. Use extreme caution and replace the guard after completion.**

1. Adjust the fence so that the distance between the edge of the knife and the fence is equal to the width of the desired rabbet (Figure 26).
2. Lower the infeed table to the depth of the rabbet required. If the rabbet is quite deep it may be necessary to do it in increments.



Figure 26

## Adjusting the Infeed Table Height

The height of the infeed table with respect to the cutting circle will determine the amount of material to be removed from the work piece. To raise or lower the table, turn the height adjusting wheel (A, Figure 27), located below the infeed table, to the desired height indicated by the gauge (B, Figure 27). Once the desired height is set the table can be locked into place (C, Figure 27).

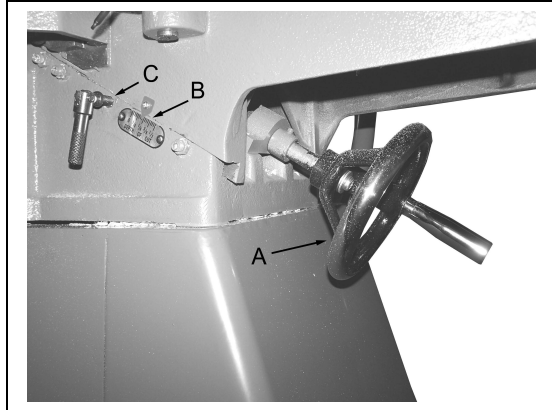

Figure 27

## Table Leveling

Over time the table gibs will wear causing the tables to become un-parallel. At this time it becomes necessary to tighten the gibs using the set screws (A, Figure 30). First loosen the jam nuts and then turn in the set screws until they make good contact with the gibs. Tighten the jam nuts.

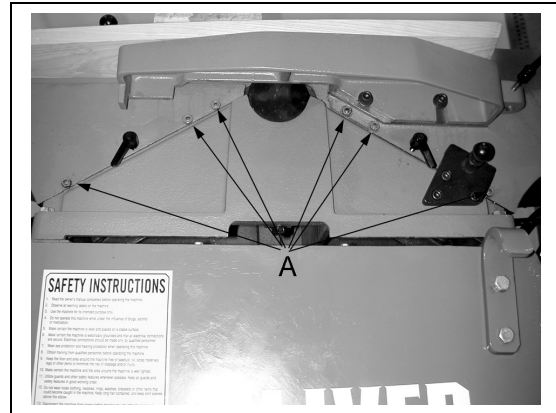

Figure 30

## Maintenance

### Lubrication

Periodically apply a light grease to the tables up/down lead screw. As well, apply a light oil to the dovetail ways from time to time to allow ease of movement.

The cutterhead bearings are permanently greased for life and do not require care.

### Knives

When knives become gummed up with pitch carefully clean them with a strong solvent. A knife in this condition will not only give a poor cut it will allow heat to build up quickly thus putting undue stress on the machine.

Dull knives can be replaced or sharpened. Check in your local yellow pages for a sharpening service. It may be more cost effective to replace rather than sharpen.

*Note; Do not run the machine with dull knives. Not only will they give a bad cut, they put undue stress and vibration on the machine thereby decreasing the life of the machine and damaging the cutterhead bearings.*



## Troubleshooting

Description of Symptoms	Possible Cause	Corrective Action
Machine will not start	<ol style="list-style-type: none"> <li>1. Fuse blown or circuit breaker tripped</li> <li>2. Cord Damaged</li> <li>3. Faulty switch</li> <li>4. Not connected to power source</li> <li>5. No power to machine</li> <li>6. Emergency stop button pressed</li> </ol>	<ol style="list-style-type: none"> <li>1. Replace fuse or reset circuit breaker</li> <li>2. Have cord replaced</li> <li>3. Replace switch</li> <li>4. Check connection</li> <li>5. Check voltage</li> <li>6. Rotate emergency stop button clockwise until it pops out</li> </ol>
Cutterhead does not come up to speed	<ol style="list-style-type: none"> <li>1. Cable too light or too long</li> <li>2. Low current</li> <li>3. Motor not wired for correct voltage</li> </ol>	<ol style="list-style-type: none"> <li>1. Replace with adequate size cable</li> <li>2. Contact local electric company</li> <li>3. Refer to motor nameplate for correct voltage</li> </ol>
Unsatisfactory finish	<ol style="list-style-type: none"> <li>1. Dull Knives</li> <li>2. Gum or pitch on knives</li> </ol>	<ol style="list-style-type: none"> <li>1. Sharpen or replace knives</li> <li>2. Clean or replace knives</li> </ol>
Excessive vibration	<ol style="list-style-type: none"> <li>1. Machine not level.</li> <li>2. Damaged knives</li> <li>3. Bad V-belts</li> <li>4. Bent pulley</li> <li>5. Improper motor mounting</li> <li>6. Loose hardware</li> </ol>	<ol style="list-style-type: none"> <li>1. Reposition on flat, level surface</li> <li>2. Replace knives</li> <li>3. Replace V-belts</li> <li>4. Replace pulley</li> <li>5. Check and adjust motor</li> <li>6. Tighten hardware</li> </ol>
Adjustments do not move freely.	Sawdust and debris in mechanisms	Clean and regrease
Finished stock is concave on the end	Knife is higher than the outfeed table	Adjust the outfeed table to the highest point of the cutting circle
Back end of the stock is thicker than the front end	Knife is higher than the outfeed table	Adjust the outfeed table to the highest point of the cutting circle
Finished stock is concave or convex in the middle	Tables are not level with each other.	Level one of the tables to the other.