

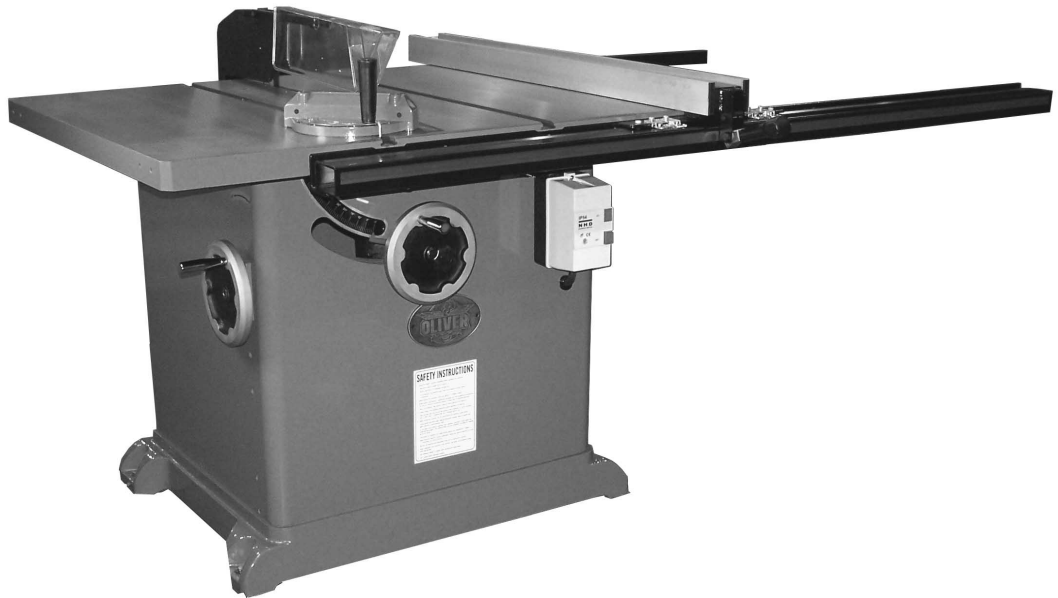

4060 16" Professional Tablesaw

Owner's Manual



Oliver Machinery
Seattle, WA
info@olivermachinery.net

M-4060 4/2019
© Copyright 2003-2019
www.olivermachinery.net

Warranty

Oliver makes every effort possible to assure that its equipment meets the highest possible standards of quality and durability. All products sold by Oliver are warranted to the original customer to be free from defects for a period of 2 (two) years on all parts, excluding electronics and motors, which are warranted for 1 year. Oliver's obligation under this warranty shall be exclusively limited to repairing or replacing (at Oliver's option) products which are determined by Oliver to be defective upon delivery F.O.B. (return freight paid by customer) to Oliver, and on inspection by Oliver. This warranty does not apply to defects due, directly or indirectly, to misuse, abuse, negligence, accidents, unauthorized repairs, alterations, lack of maintenance, acts of nature, or items that would normally be consumed or require replacement due to normal wear. In no event shall Oliver be liable for death, personal or property injury, or damages arising from the use of its products.

Warning

Read this manual thoroughly before operating the machine. Oliver Machinery disclaims any liability for machines that have been altered or abused. Oliver Machinery reserves the right to effect at any time, without prior notice, those alterations to parts, fittings, and accessory equipment which they may deem necessary for any reason whatsoever.

For More Information

Oliver Machinery is always adding new Industrial Woodworking products to the line. For complete, up-to-date product information, check with your local Oliver Machinery distributor, or visit www.olivermachinery.net

WARNING

Read this manual completely and observe all warning labels on the machine. Oliver Machinery has made every attempt to provide a safe, reliable, easy-to-use piece of machinery. Safety, however, is ultimately the responsibility of the individual machine operator. As with any piece of machinery, the operator must exercise caution, patience, and common sense to safely run the machine. Before operating this product, become familiar with the safety rules in the following sections.

- **Always keep guards in place and in proper operating condition.**
 - **Use blade guard for every applicable operation including all through cuts. If guard is removed for special non-through cuts such as dado and rabbet cuts, replace before further use of the saw.**
 - **Keep hands out of line with the saw blade.**
 - **Use a push stick.**
 - **Do not perform any operation freehand.**
 - **Never reach around or over the saw blade.**
1. **If you are not properly trained** in the use of a tablesaw do not use until the proper training has been obtained.
 2. **Read, understand and follow** the safety instructions found in this manual. Know the limitations and hazards associated with this machine.
 3. **Electrical grounding:** Make certain that the machine frame is electrically grounded and that a ground lead is included in the incoming electrical service. In cases where a cord and plug are used, make certain that the grounding plug connects to a suitable ground. Follow the grounding procedure indicated in the National Electrical Code.
 4. **Eye safety:** Wear an approved safety shield, goggles, or glasses to protect eyes. Common eyeglasses are only impact-resistant, they are not safety glasses.
 5. **Personal protection:** Before operating the machine, remove tie, rings, watch and other jewelry and roll up sleeves above the elbows. Remove all loose outer clothing and confine long hair. Protective type footwear should be used. Where the noise exceeds the level of exposure allowed in Section 1910.95 of the OSHA Regulations, use hearing protective devices. Do not wear gloves.
 6. **Guards:** Keep the machine guards in place for every operation for which they can be used. If any guards are removed for maintenance, DO NOT OPERATE the machine until the guards are reinstalled.
 7. **Work area:** Keep the floor around the machine clean and free of scrap material, saw dust, oil and other liquids to minimize the danger of tripping or slipping. Be sure the table is free of all scrap, foreign material and tools before starting to use the machine. Make certain the work area is well lighted and that a proper exhaust system is used to minimize dust. Use anti-skid floor strips on the floor area where the operator normally stands and mark off machine work area. Provide adequate work space around the machine.
 8. **Material condition:** Do not attempt to saw boards with loose knots or with nails or other foreign material. Do not attempt to saw twisted, warped, bowed stock.
 9. **Operator position:** Maintain a balanced stance and keep your body under control at all times.
 10. **Before starting:** Before turning on machine, remove all extra equipment such as keys, wrenches, scraps, and cleaning rags away from the machine.

11. **Careless acts:** Give the work you are doing your undivided attention. Looking around, carrying on a conversation, and “horseplay” are careless acts that can result in serious injury.
12. **Disconnect all power sources:** Before performing any service, maintenance, adjustments or when changing blades. A machine under repair should be RED TAGGED to show it should not be used until the maintenance is complete.
13. **Job completion:** If the operator leaves the machine area for any reason, the tablesaw should be turned “off” and the blade should come to a complete stop before their departure. The key should be placed in the “off” position, removed and given to a supervisor to prevent any unauthorized use of the tablesaw.
14. **Replacement parts:** Use only genuine Oliver Machinery factory authorized replacement parts and accessories; otherwise the warranty and guarantee is null and void.
15. **Misuse:** Do not use this Oliver tablesaw for other than its intended use. If used for other purposes, Oliver disclaims any real or implied warranty and holds itself harmless for any injury or damage which may result from that use.
16. **Drugs, alcohol and medication:** Do not operate this machine while under the influence of drugs, alcohol, or any medication.
17. **This machine is designed** for cutting wood products only. Do not use to cut any kind of metal or substance other than wood.
18. **Never start the saw** while a workpiece is in contact with the blade.
19. **Raise or lower the blade** only when the machine has been turned “off” and the blade has come to a complete stop.
20. **Miter Gauge and Rip Fence:** Never use the miter gauge and rip fence at the same time.
21. **Damaged Saw Blade:** Never use a damaged saw blade or one that has been dropped. Check the saw blade for cracks or missing teeth. Do not use a cracked or dull blade or one with missing teeth. Make sure the blade is securely locked on the arbor.
22. **Make sure** the blade is running in the proper direction. Refer to the arrow on the blade. The teeth should be pointing down when viewing from the front of the saw.
23. **Alignment:** Check the alignment of the splitter to the blade. Also, check the alignment of the fence to the miter slot.
24. **Health hazards:** Some dust created by power sanding, sawing, grinding, drilling and other construction activities contains chemicals known to cause cancer, birth defects or other reproductive harm. Some examples of these chemicals are:
 - Lead from lead-based paint.
 - Crystalline silica from bricks and cement and other masonry products.
 - Arsenic and chromium from chemically-treated lumber.Your risk from these exposures varies, depending on how often you do this type of work. To reduce your exposure to these chemicals, work in a well-ventilated area, and work with approved safety equipment, such as those dust masks that are specifically designed to filter out microscopic particles.

Familiarize yourself with the following safety notices used in this manual:

CAUTION: (This means that if precautions are not heeded, it may result in minor or moderate injury and/or possible machine damage)

WARNING: (This means that if precautions are not heeded, it could result in serious injury or possibly even death).

Table of Contents	Page Number
Warranty	2
Warnings	3-4
Table of Contents	5
Specifications	5
Contents of the Shipping Containers	6
Machine Preparation and Setup	7
Extension Wing Assembly	7
Handwheel Assembly	7
Rail Assembly	8
Fence Assembly and Adjustment	9
Adjusting the Scale Reader	9
Adjusting 45° and 90° Stops	10
Splitter and Blade Guard Assembly	11
Miter Gauge	12
Controls	12
Dust Collection	12
Electrical Connections	13
Replacing the Blade	13
Maintenance	14
Troubleshooting	15-16

Specifications

Model Number	4060
Blade Diameter (In)	16"
Arbor Diameter (In)	1"
Maximum Depth of Cut at 90 Degrees (In)	5-1/2"
Maximum Depth of Cut at 45 Degrees (In)	4-1/4"
Maximum Cut to the Right of Blade	52"
Dust Port Diameter (In)	4
Table Dimensions w/Extensions (LxW)	48-1/2" x 38"
Table Height (In)	36-1/2"
Blade Tilt	Right
Arbor Speed RPM	3,450
Overall Dimensions (with fence & rails attached)	85"L x 55"W x 42"H
Gross Weight	1040

Contents of the Shipping Containers

Oliver 4060, 16" Professional Tablesaw

Saw

Once the top is removed the saw will be as shown. Inspect for freight damage and call the freight carrier if any.

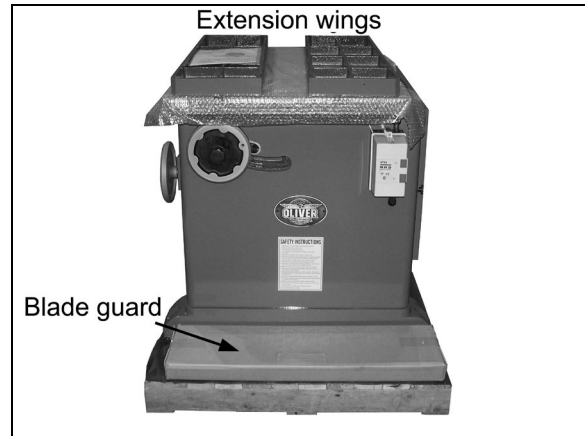

Saw

Contents

1. Speed handles
2. Angle height lock
3. Hardware packet (wings)
4. Hardware packet (rails)
5. Tools
6. Blade guard support bracket
7. Miter gauge

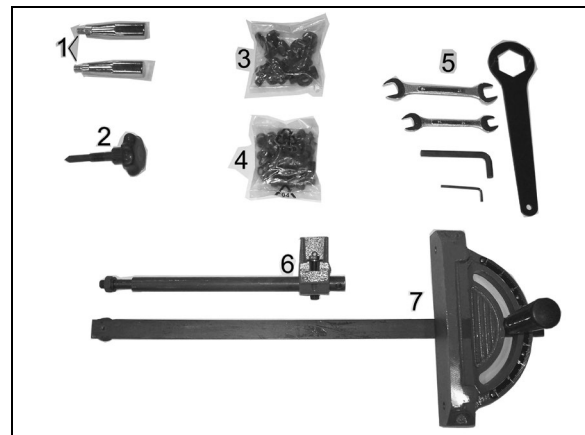

Contents

Fence and Rail Assembly

1. Fence
2. Front rail
3. Front rail support
4. Rear rail

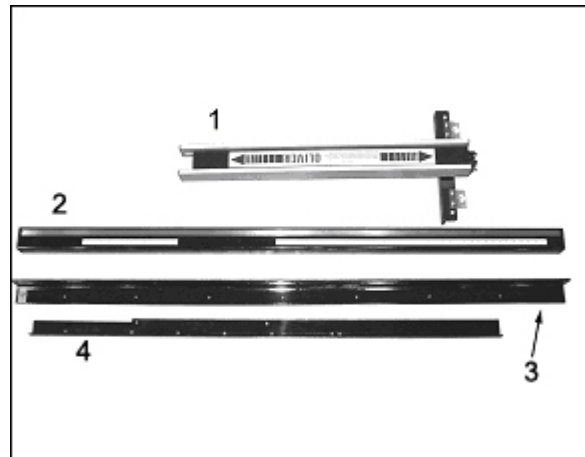

Fence and Rail Assembly

Machine Preparation and Setup

WARNING!

The equipment used to lift this machine must have a rated capacity at, or above the weight of the tablesaw. Failure to comply may cause serious injury!

The tablesaw must be positioned on a smooth, level surface. The area must be well lit and have plenty of room to maneuver with large pieces of wood.

Level the saw front to back and side to side. Make sure the saw is stable before being placed into service.

Clean all rust protected surfaces with a commercial solvent. Do not use acetone, gasoline, lacquer thinner or any type of flammable solvent, or a cleaner that may damage paint. Cover cleaned surfaces with WD-40 or a 20W machine oil.

Pay particular attention to cleaning in the miter slot and the faces of table and extension wing.

Extension Wing Assembly

1. Attach each extension wing to table using the supplied hardware as shown in figure 1. Snug but do not tighten the bolts.
2. Make sure the mating surfaces are flush at both the top of the table and the front edge of the table as shown in figure 2. If the bolts have not been completely tightened, this can be easily accomplished using a rubber coated mallet or dead blow.
3. Fully tighten the bolts.

Handwheel Assembly

1. Screw in the speed handle and angle lock knob into their respective holes as shown in figure 3. Use the supplied wrench to securely tighten the speed handle. Do the same for both handwheels.

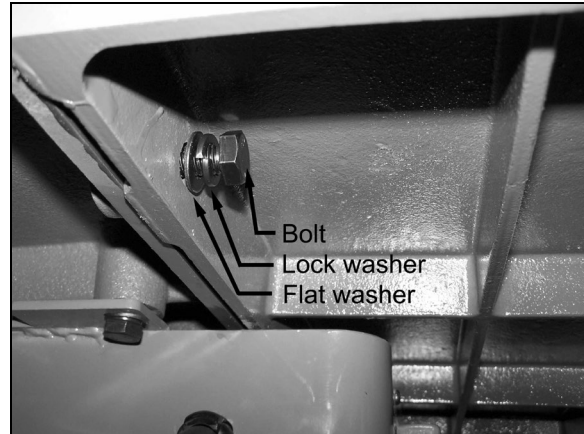

Figure 1

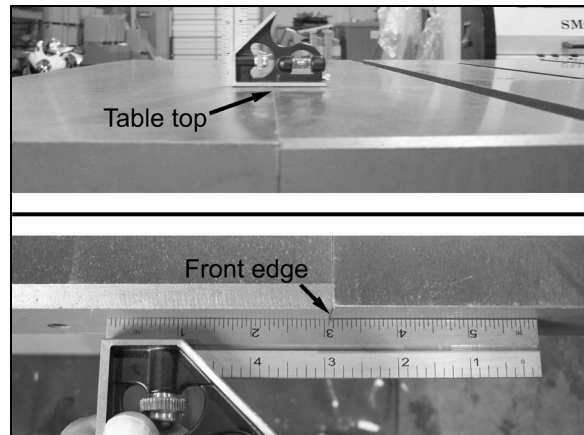

Figure 2

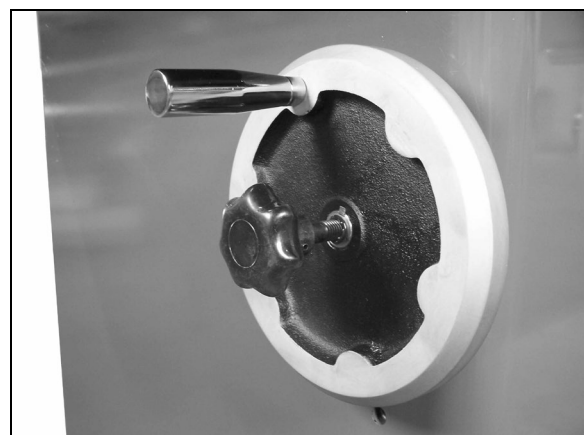

Figure 3

Rail Assembly

1. Install the front rail support to the saw using the four supplied chamfered bolts found in the hardware packet of the rails. It is easiest to start with the first hole as shown in figure 4, using the floor to rest the end of the rail on. Note that the rail comes pre-drilled for use on other saws so it is a matter of lining up the holes in the saw with the correct rail holes.

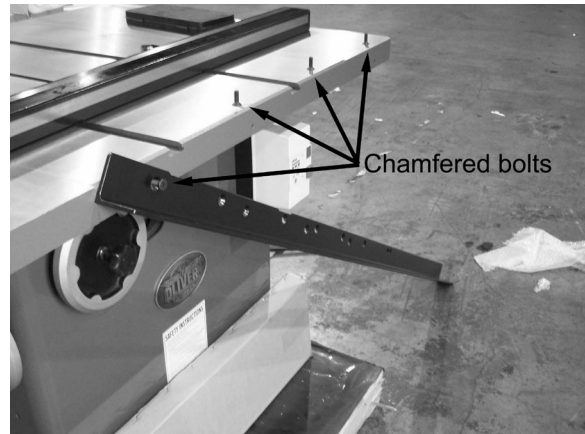

Figure 4

2. Set the front guide on the support bracket as shown in figure 5 and secure into place with the seven hex bolts also provided in hardware packet. Be careful when placing the rail on the bracket that it does not fall off when lining up the holes.

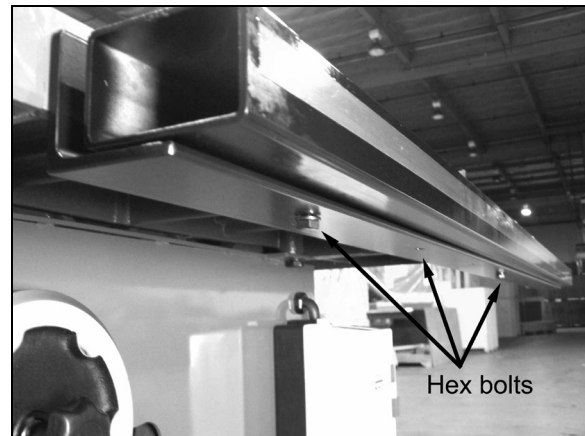

Figure 5

3. Install the rear guide as shown in figure 6 using the supplied hardware.

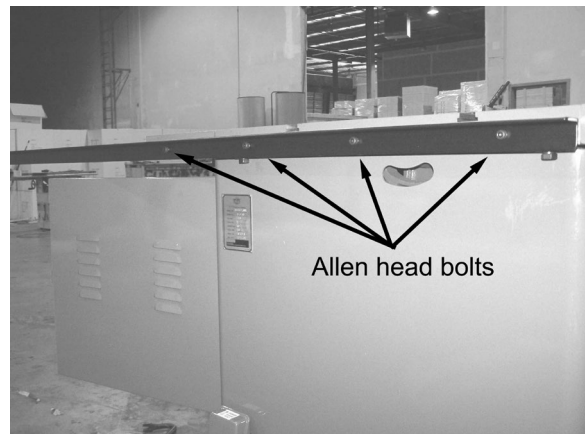

Figure 6

Fence Assembly and Adjustment

1. Place the fence on the rails and check for alignment with the mitre gauge slot as shown in Figure 7.
2. If the fence is not parallel to the mitre gauge slot, lift the fence off the guides and place it on the table as shown in figure 8. Turn the appropriate screw, B to compensate for the difference. Place the fence back on the guides and check again for alignment to the mitre gauge. If it is still mis-aligned, repeat the procedure.
3. If the fence does not securely lock into place with the lock handle, again adjust screws (B, Figure 8) inward equal amounts to put more pressure on the locking cam to the rail.
4. If the fence height with respect to the table needs to be adjusted use the leveling screws (A, Figure 8) in conjunction with the leveling knob on the other end of the fence. It is best to adjust the height as close a possible to the table as long as it doesn't rub or bind up on anything as it travels along it's rails.

Note: Before leveling the fence, remove the plastic screws (A, Figure 8) and apply a thin coat of oil to the screws before re-installing.



Figure 7

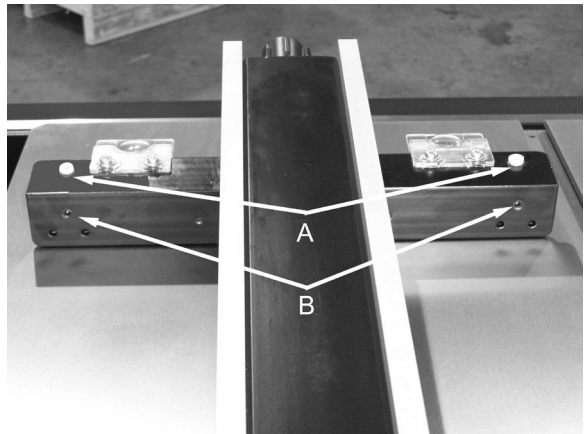

Figure 8

Adjusting the Scale Reader

1. Raise the blade to it's maximum height.
2. Place the fence on the guides on the right side of blade and then slide the fence toward the blade. Continue until the fence just touches the saw teeth. Do not push too hard or the blade will deflect.
3. Looking at the right side scale reader, the red pointer should match up with the zero mark. If not, loosen the two screws, B, Figure 9 and slide the viewer to align the mark with zero. Tighten the screws.
4. Move the fence to the left side of the blade and repeat the procedure for the left side viewer.

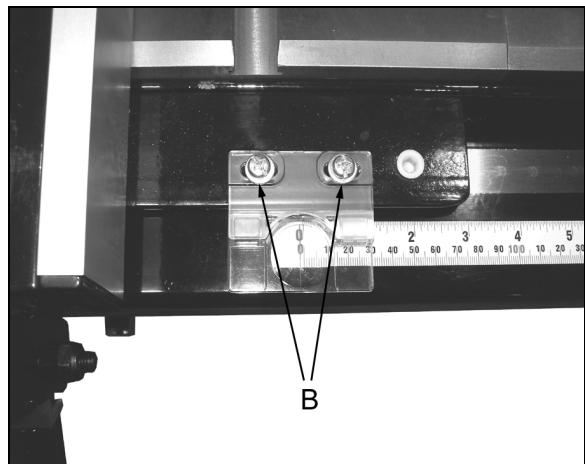

Figure 9

Adjusting 45° and 90° Stops

The stops have been adjusted at the factory and should not need any adjustment. If you need to adjust the stops:

90° Stop

1. **Disconnect saw from power source.**
2. Raise the saw blade to its maximum height by turning the blade raising handwheel clockwise as far as it will go. Place a square on the table and turn the blade tilt handwheel until the blade comes into 90 degrees with the square. Make sure the square is between the blade teeth.
3. Loosen the jam nut and turn the screw until it hits the stop (A, Figure 11).
4. If necessary, loosen the screw (B, Figure 13) and adjust the pointer to zero on the back-up angle scale.

45° Stop

1. Using a 45 gauge as shown in figure 12, tilt the blade until it makes contact with the gauge making sure the gauge does not hit the saw teeth.
2. Loosen the jam nut and adjust the bolt (A, Figure 13) until it hits the stop which is similar to the stop in figure 11 but at the other end of the rack swing.
3. Adjust the pointer if necessary.

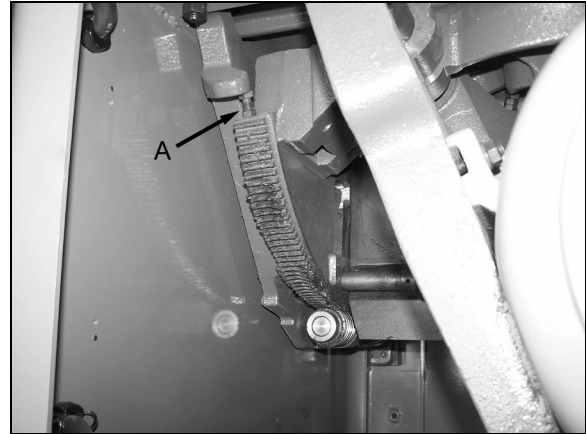

Figure 11

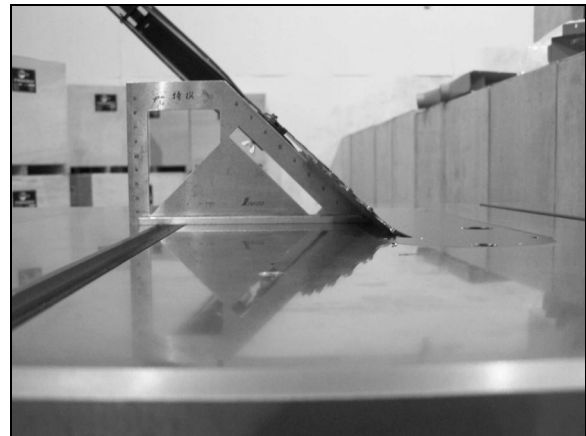

Figure 12

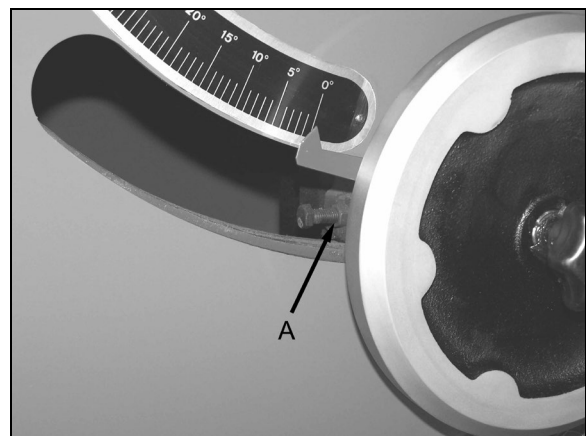

Figure 13

Splitter and Blade Guard Assembly

1. Disconnect saw from power source.
2. Insert the blade guard support rod into hole A as shown in figure 17.

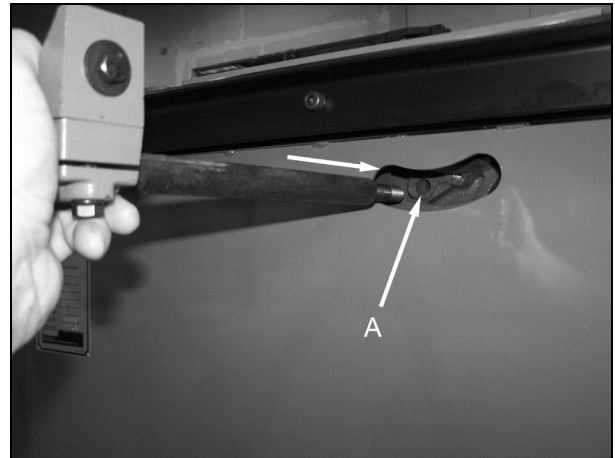

Figure 17

3. Remove the table insert then secure the blade guard support rod with lock washer (1) and nut (2) as shown in figure 18.

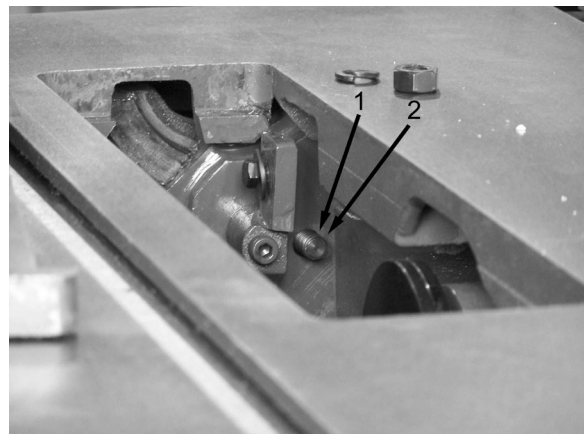

Figure 18

4. Lower the blade guard onto the front and rear brackets using the provided hex bolt and washer to secure into place as in figure 19.
5. Adjust the rear support bracket so that the rear of the blade guard is in line with the front of the blade guard and the blade itself.

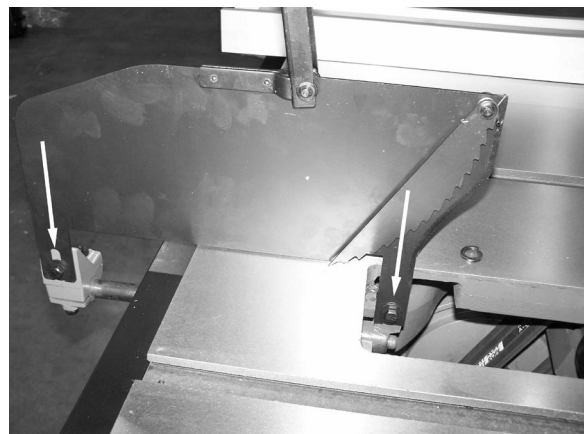

Figure 19

Miter Gauge

1. The miter gauge comes pre-assembled. Unpack the miter gauge and clean thoroughly.
2. Be certain the miter gauge 'T' slots in the table are also thoroughly cleaned.
3. The miter gauge is guided through the 'T' slot with a roller guide at the front of the guide bar. To insert miter gauge, first insert roller guide into 'T' slot at front of table.

Note: Always make test cuts. The scale is for reference. There are two holes in the miter gauge fence used to attach a wooden fence.

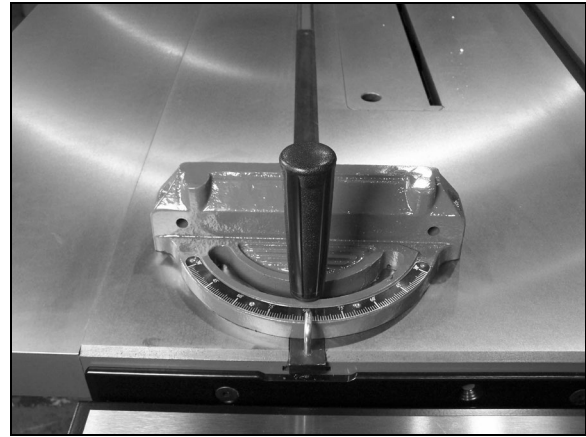

Figure 23

Controls (see Figures 24 & 25)

1. **Magnetic Switch:** Stops and starts the machine. This switch also provides overload protection for the saw motor (Figure 24).
2. **Handwheel Lock:** There is a handwheel lock on both handwheels (B & D of Figure 25). Loosen lock to turn handwheel and tighten when blade is in desired location.
3. **Blade Height Adjustment:** Loosen handwheel lock. Turn handwheel 'C' clockwise to raise the blade. The blade should be 1/8"-1/4" above the top of workpiece, or 3-5 blade teeth above the top of workpiece.
4. **Blade Tilt Adjustment:** Loosen handwheel lock. Turn handle 'B' to tilt blade.



Figure 24

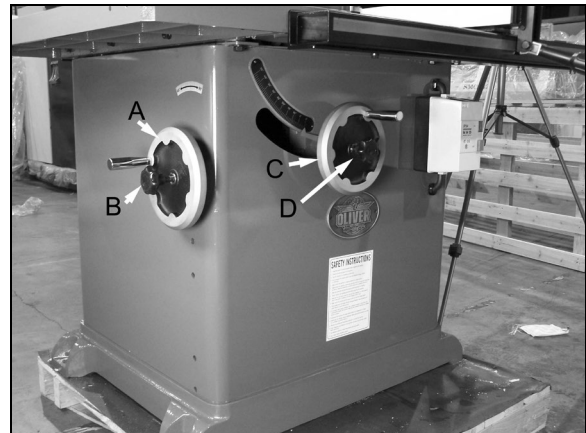

Figure 25

Dust Collection

There is a 4" dust port located on the side of saw cabinet. Make sure dust collection system has sufficient capacity and suction for your tablesaw. Always turn on dust collection system before starting the tablesaw.

Electrical Connections

WARNING!

Electrical connections and wiring must be done by a qualified electrician. The machine must be properly grounded. Failure to comply may cause serious injury!

This saw is available in both 1-Phase and 3-Phase versions.

- **Electrical Connections for a 3-Phase Unit**

This saw is 3-Phase, 220V/440V **pre-wired 220V**. If you need to switch the tablesaw from 220V to 440V have a qualified electrician make the changes. Note: Extra parts are required (#3046.00 440V) Oliver Machinery recommends using a dedicated circuit.

Make sure the voltage of your power supply matches the specifications on the motor plate of the machine.

Note: On initial start up, turn the saw on with out the saw blade installed in order to confirm the correct rotation. If the saw blade is on and turning in the wrong direction, the arbor nut could loosen, causing the arbor to sustain damage.

The arbor should spin toward the user when standing in front of the saw. If it does not, disconnect the power source and reverse any two power leads, L1, L2, or L3.

Replacing the Blade

1. **Disconnect saw from power source.**
2. Remove the blade guard.
3. Remove the table insert and raise the blade completely.
4. Use a piece of wood as a wedge to hold the blade in place while loosening the arbor nut with the supplied wrench as shown in figure 26. Remove the nut, flange and blade.

Note: Make sure the blade and arbor are clean before installing a new blade. The blade teeth should point down when viewing from the front of saw. The arbor nut is reverse thread as shown in figure 26.

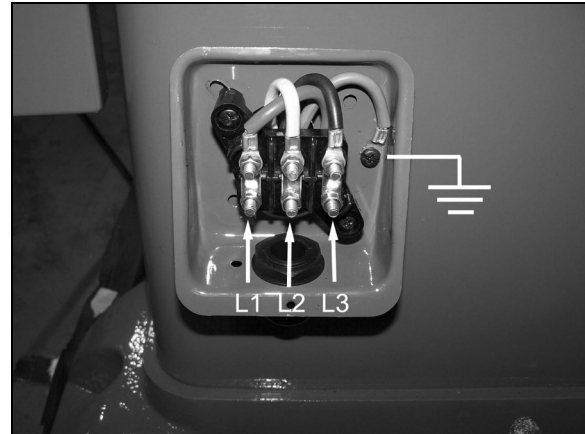

Figure 26



Figure 26

Maintenance

WARNING!

Disconnect the machine from power source before proceeding with any maintenance, or troubleshooting! Failure to comply may cause serious injury!

Periodically clean the inside of the machine for dust control. Use an air hose to blow out dust from motor fan and motor cover.

As needed, use a wire brush to clean trunions and worm gears. Apply a medium viscosity grease white lithium grease or powdered graphite to lubricate worm gears, and trunions.

Periodically lubricate all internal bearing or wear surfaces with a medium viscosity machine oil. Be sure to lubricate trunion ways and all bushings. Occasionally oil all other bearing points, including blade guard assembly, miter gauge, and rip fence.

Keep pulleys and belts free from dirt, dust, oil and grease.

Replace worn v-belts as needed.

Note: To remove the V-belts set the blade to 90 degrees and adjust to the lowest height.

Remove rust from the tabletop with a lubricant WD-40 and a Scotch-Brite™ Hand Pad. Keep a light coat of lubricant on the table top when not in use.

Note: Instead of oil, a good quality paste wax can be applied to the rip fence and table surface. Paste wax will enhance the movement of work pieces across the surface to which it is applied. In addition to being a lubricant, paste wax will help prevent surfaces from rusting.

All bearings on the arbor are shielded and permanently lubricated at the factory.

Replace belts and worn parts when needed. If power cords are worn, cut or damaged in any way, have them replaced immediately.

Make sure the teeth of the antikickback pawls are always sharp. Sharpen the dull teeth using a few light strokes of a fine-cut file.

Troubleshooting

Description of Symptoms	Possible Cause	Corrective Action
Machine will not start	<ol style="list-style-type: none"> 1. Fuse blown or circuit breaker tripped 2. Cord Damaged 3. Faulty switch 4. Not connected to power source 5. Connected to wrong voltage 6. Key in the "OFF" position 7. Emergency stop button pressed 	<ol style="list-style-type: none"> 1. Replace fuse or reset circuit breaker 2. Have cord replaced 3. Replace switch 4. Check connection 5. Check voltage 6. Insert key and turn to "ON" position 7. Rotate emergency stop button clockwise until it pops out
Blade does not come up to speed	<ol style="list-style-type: none"> 1. Cable too light or too long 2. Low current 3. Motor not wired for correct voltage 	<ol style="list-style-type: none"> 1. Replace with adequate size cable 2. Contact local electric company 3. Refer to motor nameplate for correct voltage
Does not make accurate 45° or 90° cuts	<ol style="list-style-type: none"> 1. Stops not adjusted correctly 2. Angle pointer not set accurately 3. Miter gauge out of adjustment 	<ol style="list-style-type: none"> 1. Check blade with combination square and adjust stops 2. Check blade with combination square and adjust pointer 3. Adjust miter gauge
Saw makes unsatisfactory cuts	<ol style="list-style-type: none"> 1. Dull blade 2. Blade mounted backwards 3. Gum or pitch on blade 4. Incorrect blade for cut 	<ol style="list-style-type: none"> 1. Sharpen or replace blade 2. Turn blade around 3. Remove blade and clean 4. Change blade to correct type
Material binds blade when ripping	<ol style="list-style-type: none"> 1. Fence not aligned with blade 2. Warped wood 3. Excessive feed rate 4. Splitter not aligned with blade 	<ol style="list-style-type: none"> 1. Check and adjust fence 2. Select another piece of wood 3. Reduce feed rate 4. Align splitter with blade

Saw vibrates excessively	<ol style="list-style-type: none"> 1. Stand on uneven floor 2. Damaged saw blade 3. Bad V-belts 4. Bent pulley 5. Improper motor mounting 6. Loose hardware 	<ol style="list-style-type: none"> 1. Reposition on flat, level surface 2. Replace saw blade 3. Replace V-belts 4. Replace pulley 5. Check and adjust motor 6. Tighten hardware
Material kicked back from blade	<ol style="list-style-type: none"> 1. Rip fence out of alignment 2. Splitter not aligned with blade 3. Feeding stock without rip fence 4. Splitter not in place 5. Dull blade 6. Letting go of material before it is past blade 7. Anti-kick back paws dull 	<ol style="list-style-type: none"> 1. Align rip fence with miter slot 2. Align splitter with blade 3. Install and use rip fence 4. Install and use splitter (with guard) 5. Replace blade 6. Push material all the way past blade before releasing work 7. Replace or sharpen anti-kick back paws
Blade does not raise or tilt freely	Sawdust and debris in raising and tilting mechanisms	Clean and regrease

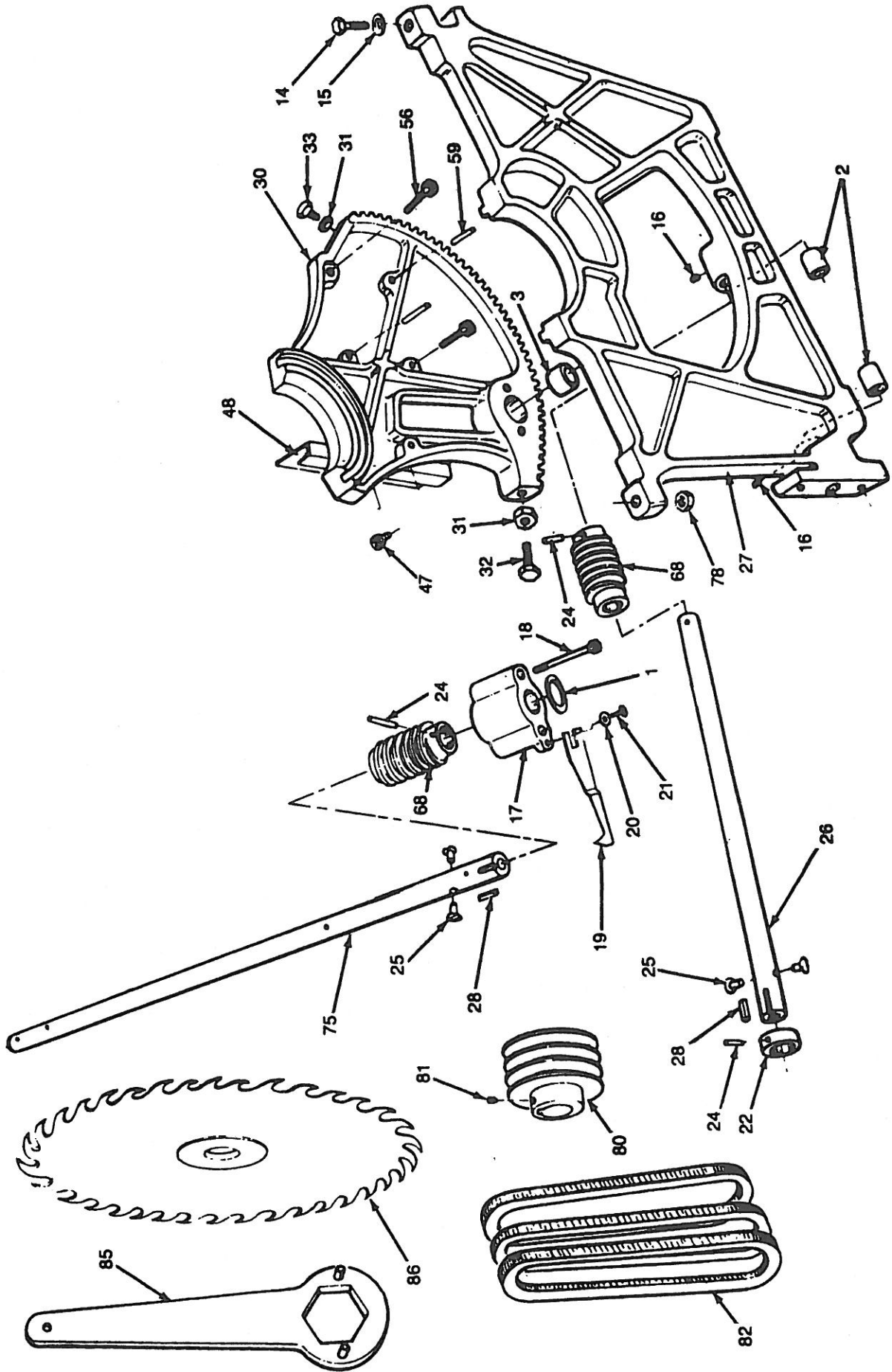

Figure 3 — Replacement Parts Illustration for Main Mechanism

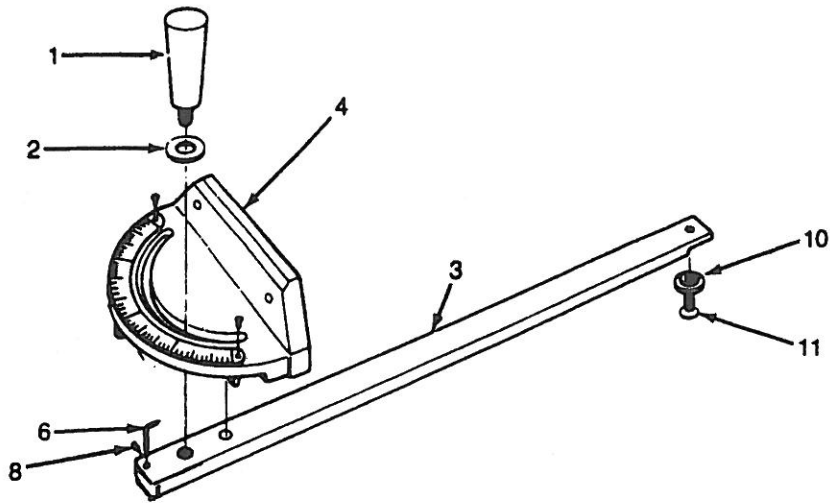

Figure 1 — Replacement Parts Illustration for Miter Gauge

Replacement Parts List for Miter Gauge

REF. NO.	DESCRIPTION	PART NO.	QTY.	REF. NO.	DESCRIPTION	PART NO.	QTY.
1	Handle	1086.00	1	6	Indicator	1091.00	1
2	Washer, 10mm	1087.00	1	8	Setscrew, 6mm - 1.0 x 6	0964.00	1
3	Bar	3001.00	1	10	Roller guide	.00	1
4	Gauge	3002.00	1	11	Flat head screw, 6mm - 1.0 x 8	1095.00	1

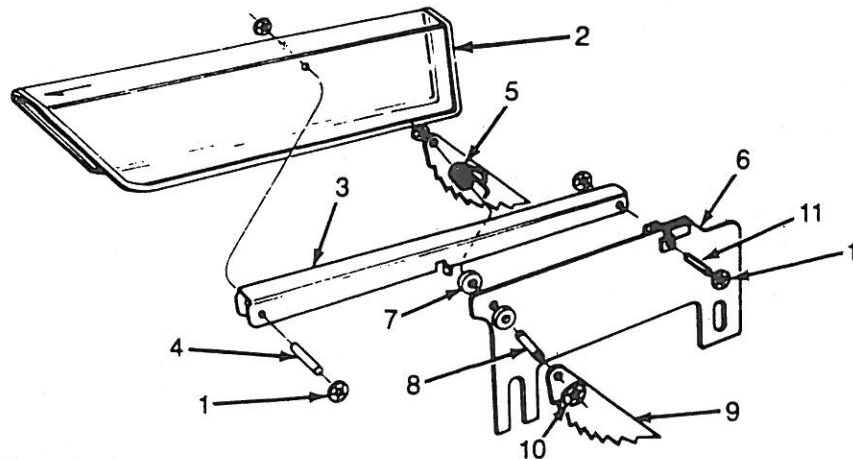
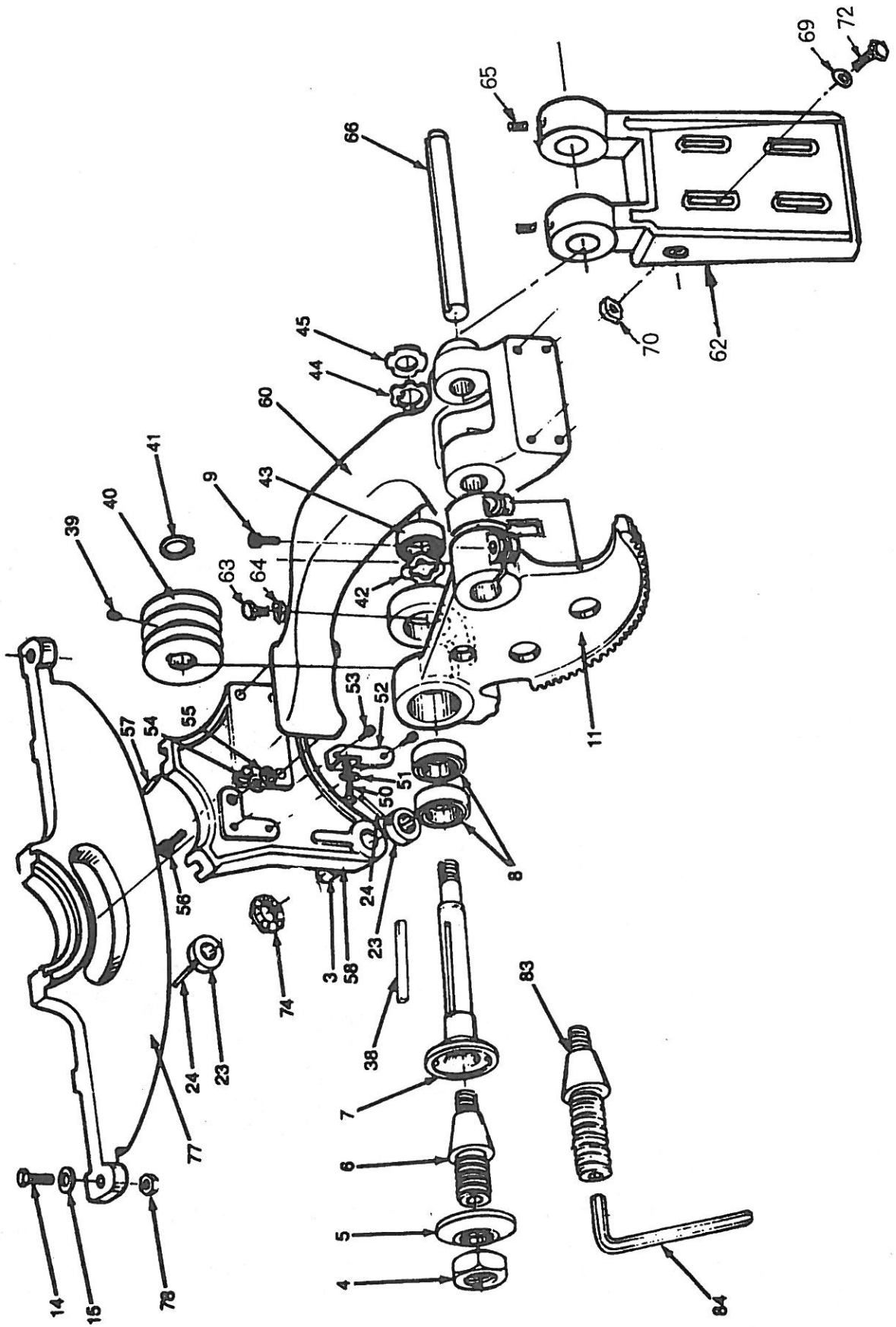

Figure 2 — Replacement Parts Illustration for Guard Assembly

Replacement Parts List for Guard Assembly

REF. NO.	DESCRIPTION	PART NO.	QTY.	REF. NO.	DESCRIPTION	PART NO.	QTY.
1	Push nut	1069.00	4	6	Spreader	3006.00	1
2	Clear blade guard	1070.00	1	7	Spacer	1075.00	2
3	Guard support	3004.00	1	8	Pin	1076.00	1
4	Pin	1072.00	1	9	Antikickback pawl	3007.00	2
5	Spring	1073.00	1	10	Snap ring	1078.00	2
				11	Pin	1079.00	1



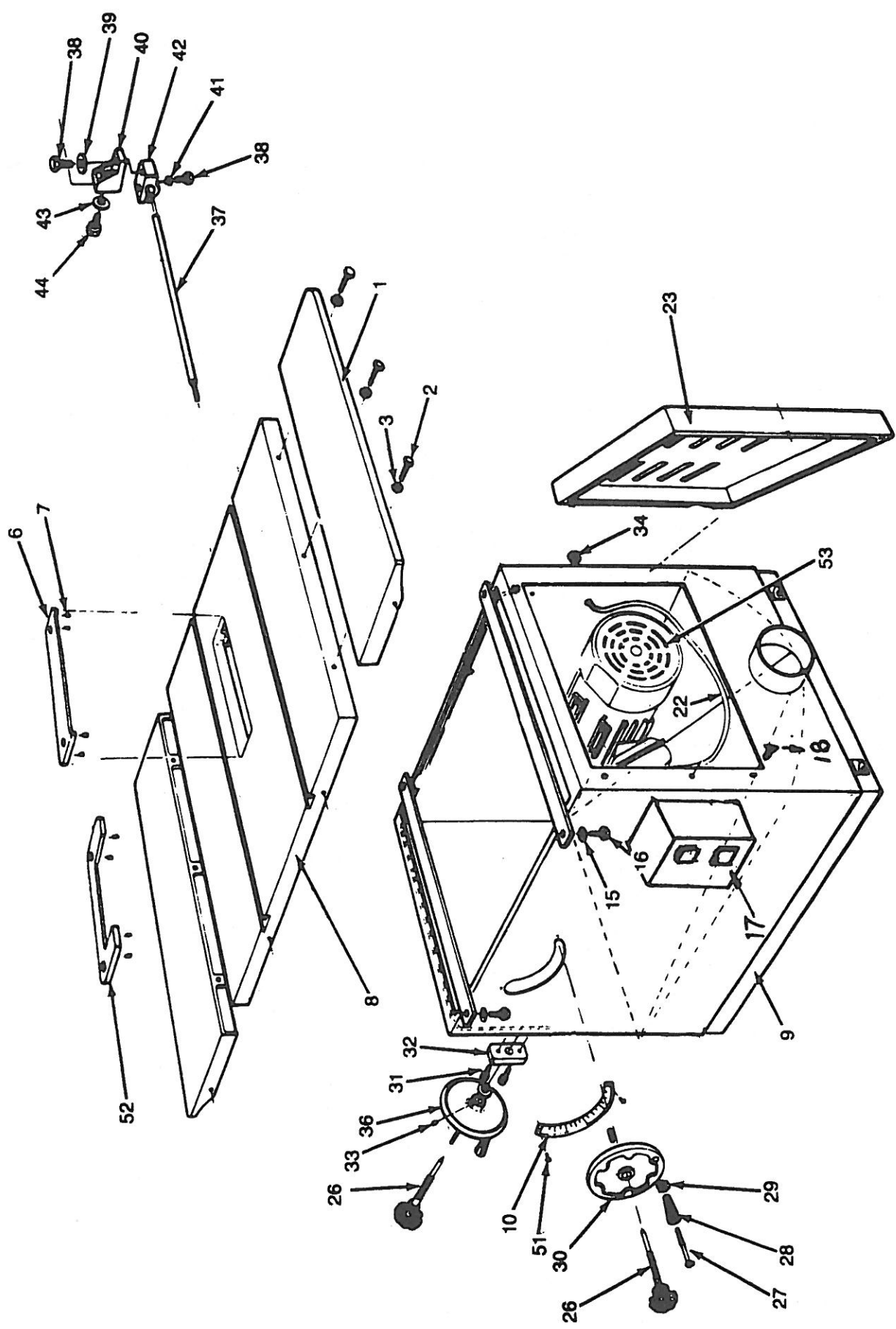

Figure 4 — Replacement Parts Illustration for Table and Base Assembly

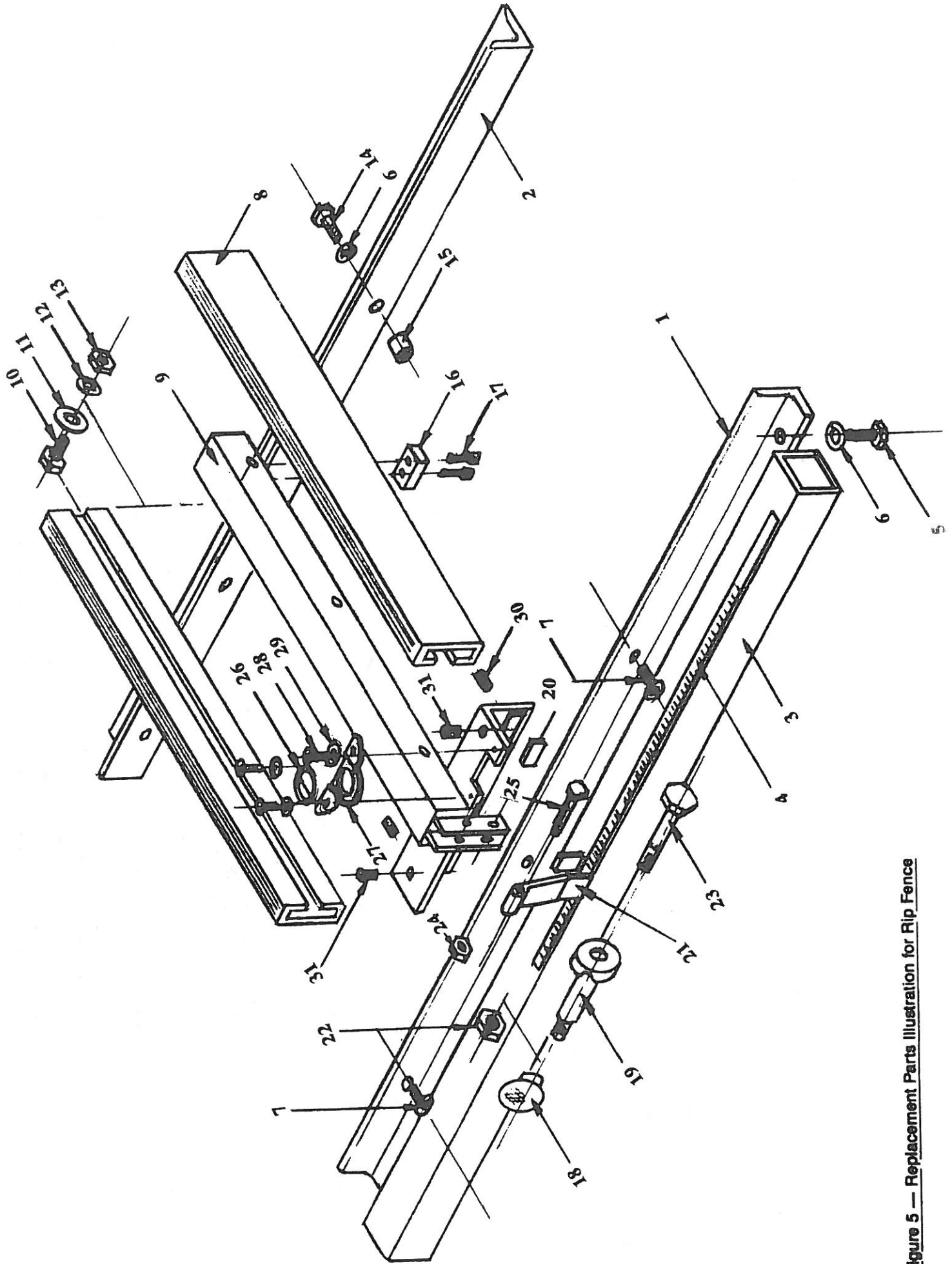

Figure 5 — Replacement Parts Illustration for Rip Fence

4060 Parts List

Replacement Parts List for Main Mechanism

REF. NO.	DESCRIPTION	PART NO.	QTY.
2	Bushing	3055.00	2
3	Bushing	0951.00	2
4	Arbor Nut (1" I.D.)	0952.00	1
5	Blade Flange (1" I.D.)	0953.00	1
6	Arbor Extension (for 1" O.D. blade)	0954.00	1
7	Arbor	3008.00	1
8	Bearing, 6006ZZ	3009.00	2
9	Socket Head Bolt, 8mm - 1.25 x 25	0957.00	2
10	Bearing Nut	3040.00	1
11	Arbor Bracket	3010.00	1
14	Hex Head Bolt, 12mm - 1.5 x 35	3011.00	4
15	Lock Washer, 12mm	3012.00	4
16	Set Screw, 6mm - 1.0 x 6	0964.00	2
17	Indicator Bracket	3013.00	1
18	Socket Head Bolt, 5mm - 80 x 75	0966.00	2
19	Indicator Bracket	0967.00	1
20	Washer, 5mm	0968.00	1
21	Round Head Screw, 5mm - 80 x 8	0969.00	1
22	Collar	3014.00	2
23	Collar	3014.00	2
24	Roll Pin	0971.00	4
25	Limit Stud	3015.00	4
26	Tilt Adjustment Shaft	3016.00	1
27	Front Trunnion Bracket	3017.00	1
28	Key, 5mm x 5mm x 25mm	3018.00	2
30	Front Trunnion	3019.00	1
31	Hex Nut, 8mm - 1.25	0978.00	2
32	Hex Head Bolt, 8mm - 1.25 x 35	0979.00	1
33	Hex Head Bolt, 8mm - 1.25 x 35	0979.00	1
38	Key, 5mm x 5mm	3020.00	1
39	Set Screw, 8mm - 1.25 x 8	0958.00	1
40	Drive pulley	3021.00	1
41	Snap Ring, R	3058.00	
42	Bearing Washer	0988.00	
43	Bearing 6204ZZ	0989.00	
44	Washer	0990.00	1
45	Locking nut, 20mm	0991.00	1
47	Socket Head Bolt, 6mm - 1.0 x 12	3022.00	2
48	Dust Deflector	3023.00	1

4060 Parts List			
<i>Replacement Parts List for Main Mechanism</i>			
REF. NO.	DESCRIPTION	PART NO.	QTY.
50	Hex Head Bolt, 8mm - 1.25 x 12	0996.00	1
51	Washer, 8mm	0997.00	1
52	Front Support Bracket	3024.00	1
53	Socket Head Bolt, 8mm - 1.25 x 25	3025.00	2
54	Lock Washer, 12mm	1000.00	1
55	Hex Nut, 12mm - 1.75	1001.00	1
56	Socket Head Bolt, 12mm - 1.75 x 30	3026.00	4
57	Pin	3028.00	2
58	Rear Trunnion Bracket	3027.00	1
59	Pin	3028.00	2
60	Arm	3029.00	1
62	Motor Mount Support	3030.00	1
63	Hex Head Bolt, 8mm - 1.25 x 35	0979.00	1
64	Hex Nut, 8mm - 1.25	0978.00	1
65	Set Screw 8mm - 1.25 x 8 mm	0958.00	2
66	Shaft	3031.00	1
68	Worm Gear	3022.00	2
69	Lock Washer, 12mm	3033.00	4
70	Hex Nut, 12mm	1001.00	4
72	Hex Head Bolt, 12mm - 1.5 x 40	3035.00	4
74	Thrust Bearing	3036.00	1
75	Height Adjustment Shaft	3037.00	1
77	Rear Trunnion Bracket	3057.00	1
78	Hex Nut, 12mm	1001.00	4
80	Motor Pulley	3038.00	1
81	Set Screw, 8mm - 1.25 x 8	0958.00	1
82	V-Belt	4L270	4
83	Arbor Extension (for Dado) (Optional)	3039.00	1
84	Set Screw Wrench, 8mm	0889.00	1
85	Spanner Wrench	1032.00	1
86	16" Blade Not Included / Local Purchase		1
△	Set Screw Wrench, 5mm	0150.00	1
△	Set Screw Wrench, 3mm	0149.00	1
△	Spanner 12 x 14 Wrench	1034.00	1
△	Spanner 17 x 19 Wrench	1035.00	1

△ Not Shown

4060 Parts List			
<i>Replacement Parts List for Table and Base Assembly</i>			
REF. NO.	DESCRIPTION	PART NO.	QTY.
1	Extension Table	3040.00	2
2	Hex Head Bolt, 12mm - 1.75 x 35	3041.00	8
3	Lock Washer, 12mm	1000.00	8
6	Blade Insert	3042.00	1
7	Set Screw, 6m - 1.0 x 8	1043.00	4
8	Table	3043.00	1
9	Base	3044.00	1
10	Indicator Plate	3045.00	1
15	Lock Washer, 12mm	3100.00	4
16	Hex Head Bolt, 12mm - 1.75 x 35	3011.00	4
17	Magnetic Switch Assembly 220V Only	3046.00 230V	1
17	Magnetic Switch Assembly 440V Only	3046.00 440V	1
18	Round Head Screw, 5mm - 80 x 8	0969.00	2
22	Power Cord Switch to Motor	3047.00	1
23	Door	3048.00	1
26	Locking Knob	3049.00	2
28	Crank Handle w/Bolt & Nut	1061.00	2
30	Hand Wheel (Tilting)	3050.00	1
31	Socket Head Bolt, 8mm - 1.25 x 20	1064.00	2
32	Shield Plate	3051.00	1
33	Set Screw, 6mm - 1.0 x 6	0964.00	2
34	Grommet	1066.00	1
36	Hand Wheel (Height)	3050.00	1
37	Guard Support Rod	3051.00	1
38	Hex head bolt, 8mm - 1.258 x 25	1081.00	2
39	Washer, 8mm	0997.00	1
40	Rear Spreader Support (Upper)	3052.00	1
41	Lock Washer, 8mm	0984.00	1
42	Rear Spreader Support (Lower)	3085.00	1
43	Washer, 8mm	0997.00	1
44	Hex Head Bolt, 8mm - 1.25 x 12	0980.00	1
△	Junction Box Assembly	3060/61/62/63.00	1
51	Screw	1010.00	2
52	Dado Insert (Optional)	3054.00	1
53	Motor 10HP - 3PH - 220/440V	6K146	1
△	Not Shown		

4060 Parts List			
<i>Replacement Parts List for Rip Fence and Rails</i>			
REF. NO.	DESCRIPTION	PART NO.	QTY.
1.1	Round Head Phillips Screw M6*1.0P*10	000304-202	4
1.2	Flat Washer 6.3*13*2.0t	006002-023	4
1.3	Pointer	250470-620	2
1.4	SET Plastic Screw M10*1.5P*50	250472-621	2
1.5	Hex. Screw	000004-306	1
1.6	Frictional Wheel	250587-615	1
1.7	Hex. Nut M6*1.0P	008005-100	1
1.8	Frictional Plate	250602-621	1
1.9	Bracket for Frictional Plate	171993-904	1
1.10	Handle Shaft	380883-904	1
1.11	Knob	230282-615	1
1.12	Compress Cam Assembly	922141-000	1
1.13	Flat Head Screw M6*1.0P*8	002103-103	2
1.14	Lock Nut M10*1.5P(17B*12H)	008308-100	1
1.15	Frictional Plate	250471-621	2
1.16	Bracket for Frictional Plate	171372-904	1
1.17	SET Screw M8*1.25P*8	001903-105	2
1.18	End Cap	250483-615	4
1.19	Adaptor	310114-909	2
1.20	Fence Body	171877-000	1
1.21	Square Screw M8*1.25P*20	048701-101	10
1.22	Flat Washer 8.5*20*2t	006001-054	10
1.23	Hex. Nut M8*1.25P	008006-100	10
1.24	Hex. Screw M6*1.0P*45	000002-308	1
1.25	Nut M6*1.0P	008304-100	1
2	Cap Screw M8*1.25P*25	000104-108	5
3	Spring Washer 8.2*15.4	006305-100	5
4	Rear Rail	172654-000	1
5	Scale-52"	571730-000	1
6	Front Rail	190106-000	1
7	End Cap	250624-615	2
8	Rail Bracket	172655-000	1
9	Flat Head Hex Screw M8*1.25P*25/8.5*16*2	000704-102	5
10	Hex. Screw w/Flat Washer M8*1.25P*12	049201-102	9
20	Scale-12"	571729-000	1