



# 4040 12" Professional Tablesaw

## Owner's Manual



**Oliver Machinery**  
1210 Andover Park East  
Tukwila, WA 98188  
Fax: 1-206-575-2723  
Phone: 1-206-575-2722

**M-4040 8/2003**

© Copyright 2003  
[www.olivermachinery.net](http://www.olivermachinery.net)  
email: [info@olivermachinery.net](mailto:info@olivermachinery.net)

## **Warranty**

Thank you for your purchase of a genuine Oliver woodworking machine. Oliver Machinery has made every attempt to provide a machine that is safe and durable.

All Oliver products are guaranteed, to the ORIGINAL RETAIL CUSTOMER, to be free from defects for TWO YEARS FROM THE DATE OF PURCHASE. Oliver Machinery will repair or replace, at its option, any component that fails under normal use. Please note that the customer is responsible for returning the failed component to Oliver Machinery prepaid for inspection.

This warranty does not cover damages caused by misuse, accident, unauthorized repair, alteration or improper maintenance.

## **Warning**

Read this manual thoroughly before operating the machine. Oliver Machinery disclaims any liability for machines that have been altered or abused. Oliver Machinery reserves the right to effect at any time, without prior notice, those alterations to parts, fittings, and accessory equipment which they may deem necessary for any reason whatsoever.

## **For More Information**

Oliver Machinery is always adding new Industrial Woodworking products to the line. For complete, up-to-date product information, check with your local Oliver Machinery distributor, or visit [www.olivermachinery.net](http://www.olivermachinery.net)



# WARNING

Read this manual completely and observe all warning labels on the machine. Oliver Machinery has made every attempt to provide a safe, reliable, easy-to-use piece of machinery. Safety, however, is ultimately the responsibility of the individual machine operator. As with any piece of machinery, the operator must exercise caution, patience, and common sense to safely run the machine. Before operating this product, become familiar with the safety rules in the following sections.

- **Always keep guards in place and in proper operating condition.**
  - **Use blade guard for every applicable operation including all through cuts. If guard is removed for special non-through cuts such as dado and rabbet cuts, replace before further use of the saw.**
  - **Keep hands out of line with the saw blade.**
  - **Use a push stick.**
  - **Do not perform any operation freehand.**
  - **Never reach around or over the saw blade.**
1. **If you are not properly trained** in the use of a tablesaw do not use until the proper training has been obtained.
  2. **Read, understand and follow** the safety instructions found in this manual. Know the limitations and hazards associated with this machine.
  3. **Electrical grounding:** Make certain that the machine frame is electrically grounded and that a ground lead is included in the incoming electrical service. In cases where a cord and plug are used, make certain that the grounding plug connects to a suitable ground. Follow the grounding procedure indicated in the National Electrical Code.
  4. **Eye safety:** Wear an approved safety shield, goggles, or glasses to protect eyes. Common eyeglasses are only impact-resistant, they are not safety glasses.
  5. **Personal protection:** Before operating the machine, remove tie, rings, watch and other jewelry and roll up sleeves above the elbows. Remove all loose outer clothing and confine long hair. Protective type footwear should be used. Where the noise exceeds the level of exposure allowed in Section 1910.95 of the OSHA Regulations, use hearing protective devices. Do not wear gloves.
  6. **Guards:** Keep the machine guards in place for every operation for which they can be used. If any guards are removed for maintenance, DO NOT OPERATE the machine until the guards are reinstalled.
  7. **Work area:** Keep the floor around the machine clean and free of scrap material, saw dust, oil and other liquids to minimize the danger of tripping or slipping. Be sure the table is free of all scrap, foreign material and tools before starting to use the machine. Make certain the work area is well lighted and that a proper exhaust system is used to minimize dust. Use anti-skid floor strips on the floor area where the operator normally stands and mark off machine work area. Provide adequate work space around the machine.
  8. **Material condition:** Do not attempt to saw boards with loose knots or with nails or other foreign material. Do not attempt to saw twisted, warped, bowed stock.
  9. **Operator position:** Maintain a balanced stance and keep your body under control at all times.
  10. **Before starting:** Before turning on machine, remove all extra equipment such as keys, wrenches, scraps, and cleaning rags away from the machine.

11. **Careless acts:** Give the work you are doing your undivided attention. Looking around, carrying on a conversation, and “horseplay” are careless acts that can result in serious injury.
12. **Disconnect all power sources:** Before performing any service, maintenance, adjustments or when changing blades. A machine under repair should be RED TAGGED to show it should not be used until the maintenance is complete.
13. **Job completion:** If the operator leaves the machine area for any reason, the tablesaw should be turned "off" and the blade should come to a complete stop before their departure. The key should be placed in the “off” position, removed and given to a supervisor to prevent any unauthorized use of the tablesaw.
14. **Replacement parts:** Use only genuine Oliver Machinery factory authorized replacement parts and accessories; otherwise the warranty and guarantee is null and void.
15. **Misuse:** Do not use this Oliver tablesaw for other than its intended use. If used for other purposes, Oliver disclaims any real or implied warranty and holds itself harmless for any injury or damage which may result from that use.
16. **Drugs, alcohol and medication:** Do not operate this machine while under the influence of drugs, alcohol, or any medication.
17. **This machine is designed** for cutting wood products only. Do not use to cut any kind of metal or substance other than wood.
18. **Never start the saw** while a workpiece is in contact with the blade.
19. **Raise or lower the blade** only when the machine has been turned “off” and the blade has come to a complete stop.
20. **Miter Gauge and Rip Fence:** Never use the miter gauge and rip fence at the same time.
21. **Damaged Saw Blade:** Never use a damaged saw blade or one that has been dropped. Check the saw blade for cracks or missing teeth. Do not use a cracked or dull blade or one with missing teeth. Make sure the blade is securely locked on the arbor.
22. **Make sure** the blade is running in the proper direction. Refer to the arrow on the blade. The teeth should be pointing down when viewing from the front of the saw.
23. **Alignment:** Check the alignment of the splitter to the blade. Also, check the alignment of the fence to the miter slot.
24. **Health hazards:** Some dust created by power sanding, sawing, grinding, drilling and other construction activities contains chemicals known to cause cancer, birth defects or other reproductive harm. Some examples of these chemicals are:
  - Lead from lead-based paint.
  - Crystalline silica from bricks and cement and other masonry products.
  - Arsenic and chromium from chemically-treated lumber.Your risk from these exposures varies, depending on how often you do this type of work. To reduce your exposure to these chemicals, work in a well-ventilated area, and work with approved safety equipment, such as those dust masks that are specifically designed to filter out microscopic particles.

Familiarize yourself with the following safety notices used in this manual:

**CAUTION:** (This means that if precautions are not heeded, it may result in minor or moderate injury and/or possible machine damage)

**WARNING:** (This means that if precautions are not heeded, it could result in serious injury or possibly even death).

| <b>Table of Contents</b>                 | <b>Page Number</b> |
|--|--------------------|
| Warranty.....                            | 2                  |
| Warnings.....                            | 3-4                |
| Table of Contents.....                   | 5                  |
| Specifications.....                      | 5                  |
| Contents of the Shipping Containers..... | 6                  |
| Uncrating the Machine.....               | 7                  |
| Machine Preparation and Setup.....       | 7                  |
| Extension Wing Assembly.....             | 7                  |
| Handwheel Assembly.....                  | 7                  |
| Rail Assembly.....                       | 8-9                |
| Fence Assembly and Adjustment.....       | 9-10               |
| Adjusting 45° and 90° Stops.....         | 10-11              |
| Leveling Table Insert.....               | 11                 |
| Splitter and Blade Guard Assembly.....   | 11-12              |
| Miter Gauge.....                         | 13                 |
| Controls.....                            | 13                 |
| Dust Collection.....                     | 13                 |
| Electrical Connections.....              | 14                 |
| Replacing the Blade.....                 | 14                 |
| Changing Arbors.....                     | 15                 |
| Replacing and Tensioning V-Belt.....     | 15                 |
| Maintenance.....                         | 16                 |
| Troubleshooting.....                     | 16-17              |

## Specifications

|  |                                    |
|--|------------------------------------|
| Model Number.....                            | 4040                               |
| Stock No. - 4040.003.....                    | .5HP, 1Ph, 220V Only               |
| Stock No. - 4040.004.....                    | .5HP, 3Ph, 220V/440V Prewired 220V |
| Blade Diameter (In).....                     | 12                                 |
| Arbor Diameter (In).....                     | 1" or 5/8" interchangeable         |
| Maximum Width of Dado (In).....              | 13/16"                             |
| Maximum Depth of Cut at 90 Degrees (In)..... | 4"                                 |
| Maximum Depth of Cut at 45 Degrees (In)..... | 2-3/4"                             |
| Maximum Cut to the Right of Blade.....       | 36"                                |
| Maximum Cut to the Left of Blade.....        | 18"                                |
| Dust Port Diameter (In).....                 | 4                                  |
| Table Dimensions w/Extensions (LxW).....     | 30-3/4" x 42-1/2"                  |
| Table Height (In).....                       | 36                                 |
| Blade Tilt.....                              | Left                               |
| Arbor Speed RPM.....                         | 3,450                              |
| Overall Dimensions.....                      | 30-3/4L x 42-1/2"W x 42"H          |
| Gross Weight.....                            | 530                                |

## Contents of the Shipping Containers

### Oliver 4040 – 12" Professional Tablesaw

1. 12" Left Tilt Tablesaw
1. Miter Gauge
4. Wrenches
1. 5/8" Arbor
1. Arbor Nut
2. Handles



### Extension Wing Assembly

2. Extension Wings
6. M10-1.5Px30 Hex Head Bolts
6. M10 Lock Washers

### Guard Support Assembly

1. Guard Bracket
1. Guard Bracket Rod
1. Guard Mounting Bolt
2. Hex Nuts
1. Lock Washer
1. Flat Washer
1. M8-1.25x35 Hex Head Bolt
1. M8 Lock Washer

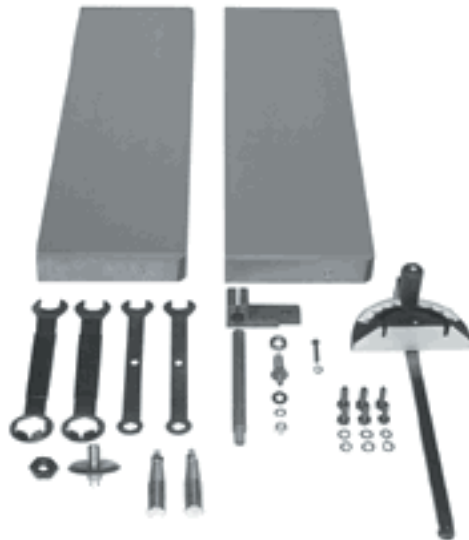

### Fence and Rail Assembly

1. Fence
1. Guide Tube
2. End Caps
1. Rear Rail
1. Blade Guard Assembly
1. Support
7. Guide Tube Brackets
5. Rear Rail Brackets
7. M8-1.5Px16 Carriage Bolts
7. Lock Washers
7. M8-1.25P Cap Nuts
12. M10-1.5Px16 Flat Head Socket Bolts
7. M10-1.5Px20 Hex Head Bolts
11. M10 Lock Washers
4. M10 Hex Nuts
2. M6-1Px10 Socket Head Cap Screw



## Uncrating the Machine

Uncrate the machine and inspect the unit for signs of shipping damage. If damage is found, contact your dealer immediately. Retain all packaging materials in case it becomes necessary to ship the machine to another site.

## Machine Preparation and Setup

### **WARNING!**

**The equipment used to lift this machine must have a rated capacity at, or above the weight of the tablesaw. Failure to comply may cause serious injury!**

The tablesaw must be positioned on a smooth, level surface. The area must be well lit and have plenty of room to maneuver with large pieces of wood.

Level the saw front to back and side to side using a level placed on the table. Use shims under the corners, if necessary, but make sure the saw is stable before being placed into service.

Clean all rust protected surfaces with a commercial solvent. Do not use acetone, gasoline, lacquer thinner or any type of flammable solvent, or a cleaner that may damage paint. Cover cleaned surfaces with WD-40 or a 20W machine oil.

Pay particular attention to cleaning in the miter slot and the faces of table and extension wing.

## Extension Wing Assembly

1. Attach extension wing (A, Figure 1) to table with three M10x30 hex head bolts, and three M10 lock washers (B, Figure 1). Snug but do not tighten. **Note:** Start with the center hole (C, Figure 1) to hold the wing in place.
2. Slide extension wing toward the front edge of the saw table until two edges are flush.
3. Using a straight edge (D, Figure 2), align extension wing to saw table and tighten hex cap bolts. Repeat for opposite wing.

## Handwheel Assembly

1. Thread handle (E, Figure 3) into handwheel (F, Figure 3). **Note:** There is a flat on the handle so it can be tightened with a wrench.

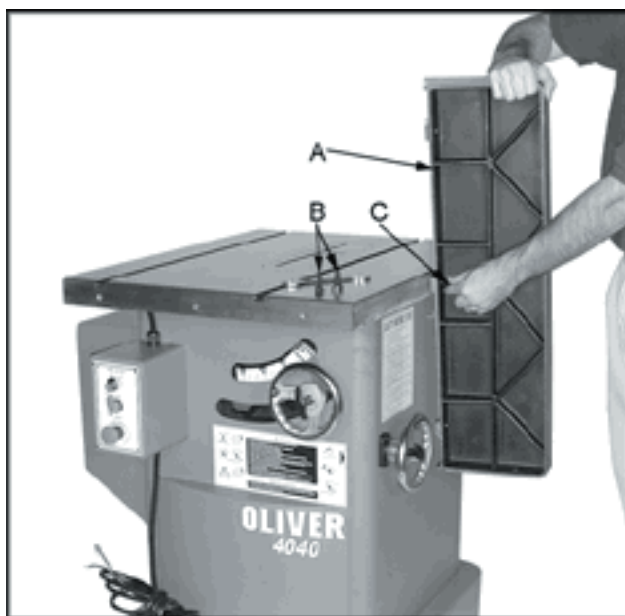

Figure 1

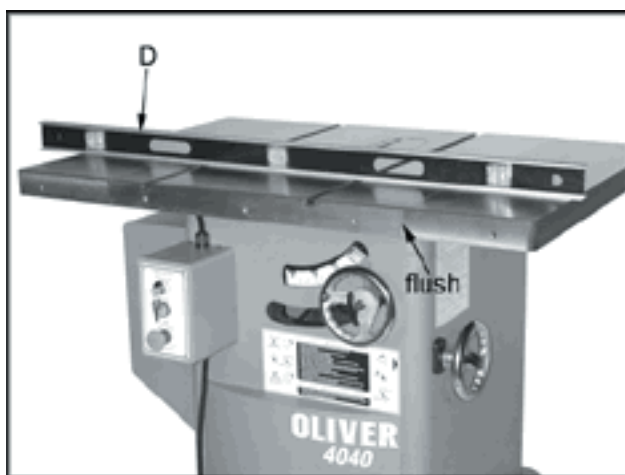

Figure 2



Figure 3

## Rail Assembly

1. Place a M8x16 carriage bolt (A, Figure 4) through the bracket (B, Figure 4) and hold in place with a M8 lock washer and M8 cap nut (C, Figure 4). **Note:** Just thread the cap nut onto carriage bolt a couple turns to hold in place. Leaving the bolt loose will make it easier to insert the head of carriage bolt into guide rail slot.
2. Angle the head of carriage bolt into the keyed slot found on the bottom of guide tube. Slide in place to engage square shoulder of carriage bolt with slot and tighten cap nut.
3. Once all of the brackets have been attached to the guide tube (D, Figure 4) mount the brackets to table using seven M10x16 flat head socket bolts (E, Figure 5).

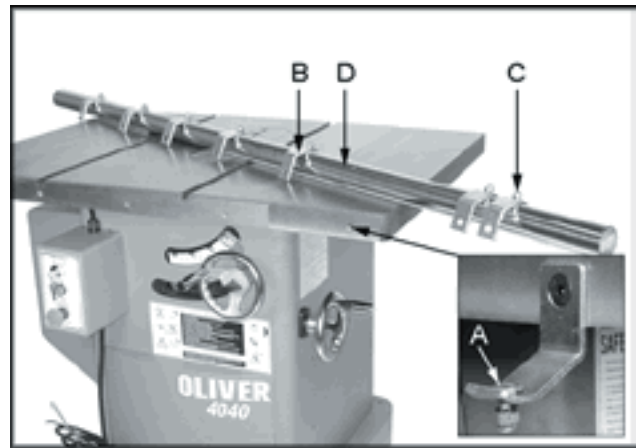

Figure 4

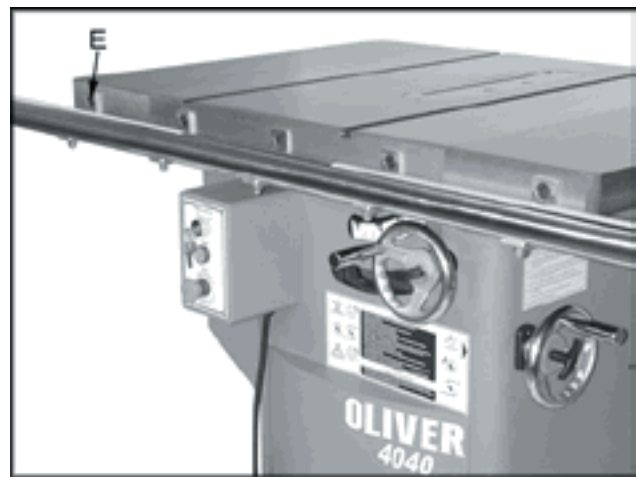

Figure 5

4. Mount the rear rail brackets (F, Figure 6) to the table with five M10x16 flat head socket bolts (G, Figure 6). Leave loose at this time.
5. Mount the rear rail (H, Figure 6) to the brackets with five M10 lock washers and five M10x20 hex head bolts (I, Figure 6).
6. Thread two M6x10 socket head cap screws (J, Figure 6) into the rear rail at both ends. They act as a stop for the fence.

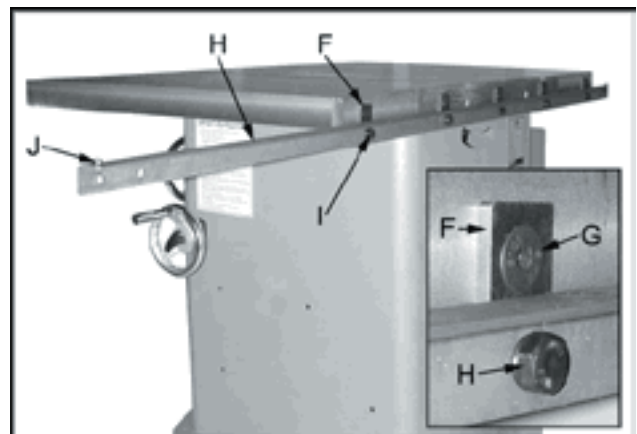

Figure 6



7. Mount the support (A, Figure 7) between the guide rail and the rear rail. Attach the front side with two M10x16 flat head socket bolts, two M10 lock washers and two M10 hex nuts (B, Figure 7).
8. Attach the rear side with two M10x20 hex head bolts, two M10 lock washers and two M10 hex nuts.

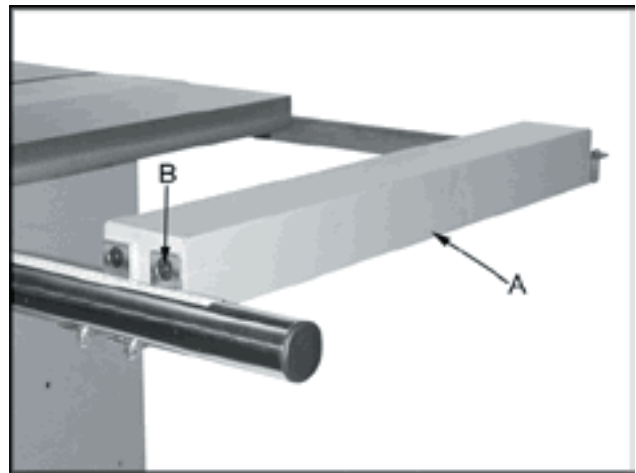

Figure 7

### Fence Assembly and Adjustment

1. Tilt rear end of the fence (C, Figure 8) down to engage clip (D, Figure 8) on to the rear rail and lower the fence on to guide rail, as shown in Figure 8.

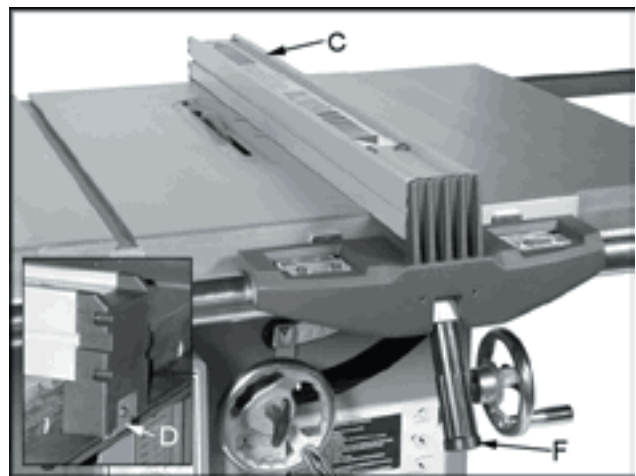

Figure 8

2. Move the fence so that the line on the cursor (E, Figure 9) reads 2" and lock the fence in place by pushing down on the handle (F, Figure 8).
3. Place a ruler (G, Figure 9) on the table and measure from the right side of the saw blade tooth to the fence. It should read 2". If not move the fence so that it measures 2" from the blade. Lock the fence in place and adjust the cursor by loosening the cursor screws (H, Figure 9) and adjust to read 2".  
**Note:** If you do not have enough adjustment in the cursor loosen cap nuts that attach the brackets to the guide tube and slide the tube left or right to get the proper adjustment. Tighten the cap nuts.



Figure 9

4. Move the fence into position so that the fence and the miter gauge slot align as shown in Figure 10. The fence should be parallel to the miter gauge slot. If not loosen the four screws (A, Figure 10).

### Adjusting 45° and 90° Stops

The stops have been adjusted at the factory and should not need any adjustment. If you need to adjust the stops:

1. **Disconnect saw from power source.**
2. Raise the saw blade to its maximum height by turning the blade raising handwheel clockwise as far as it will go.
3. Set the blade at 90° to the table by turning the blade tilting handwheel clockwise as far as it will go.
4. Place a square (B, Figure 11) on the table and check to see that the blade is at a 90° angle to the table, as shown in Figure 11. Make sure ruler is in-between the blade teeth.

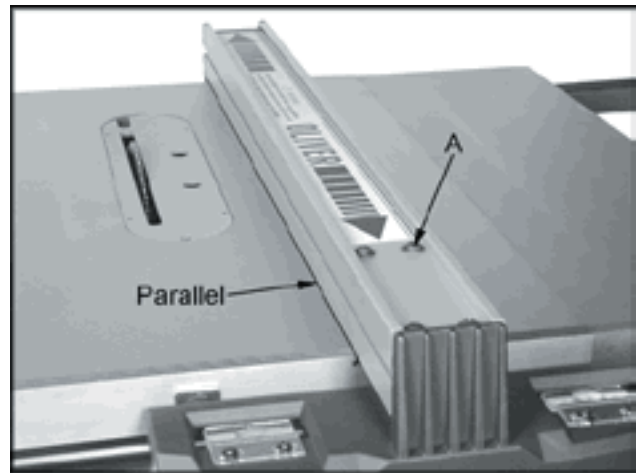

Figure 10

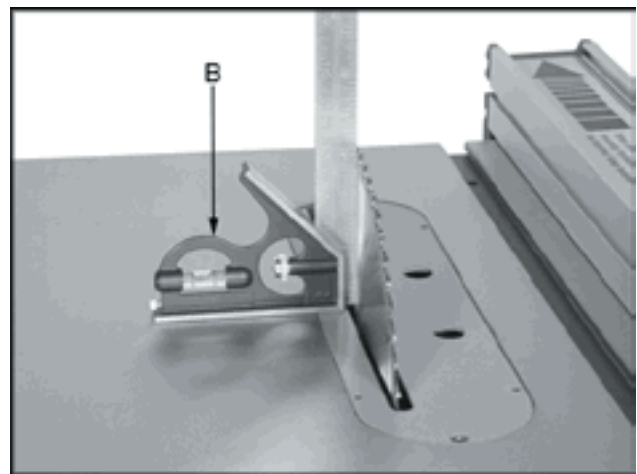

Figure 11

5. If blade is not 90° open the motor cover door, and loosen hex nuts (B, Figure 12).
6. Turn adjusting stop bolts (C, Figure 12) on the trunnion in, or out. The adjusting stop bolts should rest against the table when blade is 90° to the table.
7. Tighten the hex nuts (B, Figure 12) while holding the adjusting stop bolts (C, Figure 12) to keep them from moving.
8. Check the accuracy of the pointer and adjust if necessary. It should read 0° on the angle scale.

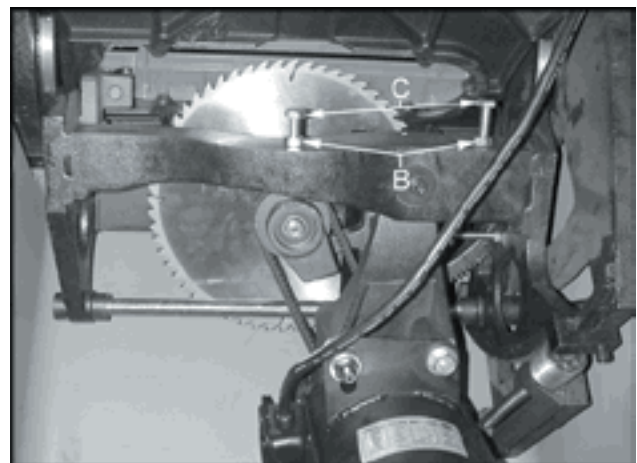

Figure 12

9. Set the blade 45° to the table by turning the blade tilting handwheel counter-clockwise as far as it will go. Place a combination square on the table and check to see that the blade is at a 45° angle to the table.
10. If the blade is not 45°, remove raising and lowering handwheel by unscrewing the handwheel lock and loosening the two set screws in the handwheel hub, as shown in Figure 13.
11. Loosen hex nut (A, Figure 13) and turn adjusting stop bolt (B, Figure 13) on the front trunnion in, or out. The adjusting stop screw should stop against the front trunnion bracket when blade is 45° to table.
12. Tighten the hex nut (A, Figure 13) while holding the adjusting stop bolt (B, Figure 13) to keep it from moving.
13. Check the accuracy of the pointer and adjust if necessary. It should read 45° on the angle scale.

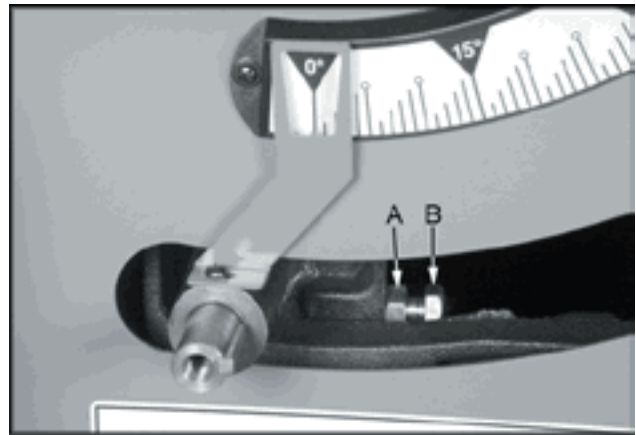

Figure 13

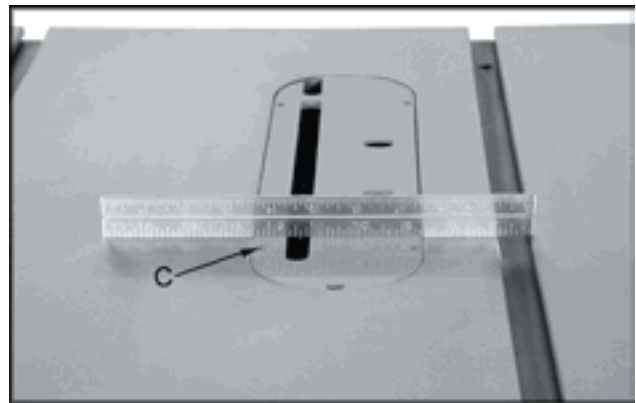

Figure 14

### Leveling Table Insert

Adjust the table insert flush with the table by turning four leveling screws (C, Figure 14). Place a straight edge across the table and insert. Raise the insert until it just touches the straight edge. Check both the front and rear section of the insert.

### Splitter and Blade Guard Assembly

1. **Disconnect saw from power source.**
2. Remove table insert by loosening the screw at the front of insert. Pull up and towards you to release the rear clip.
3. Thread blade guard shaft (D, Figure 15) into rear trunnion through opening at rear of saw. Use the flat detent at the end of shaft to tighten blade guard shaft.
4. Place bracket assembly (E, Figure 15) on to the shaft and thread a M8x35 hex head bolt and a M8 lock washer (F, Figure 15) into the bracket.
5. Thread the guard support assembly (G, Figure 15) into the bracket.

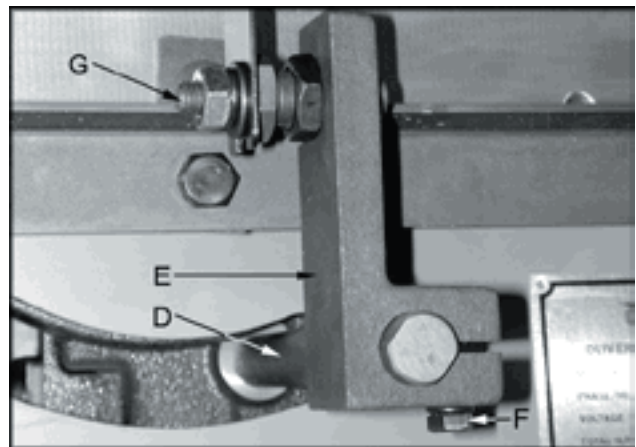

Figure 15

6. Insert front fork of blade guard assembly (A, Figure 16) through opening in the table. The tab is held in place between the flat washer and bracket, see Figure 16. Finger tighten hex nut (B, Figure 16) only at this time.
7. Insert the rear fork of the blade guard assembly (C, Figure 16) into the guard support assembly between the flat washer and shoulder, see Figure 16. Finger tighten hex nut (D, Figure 16) only at this time.

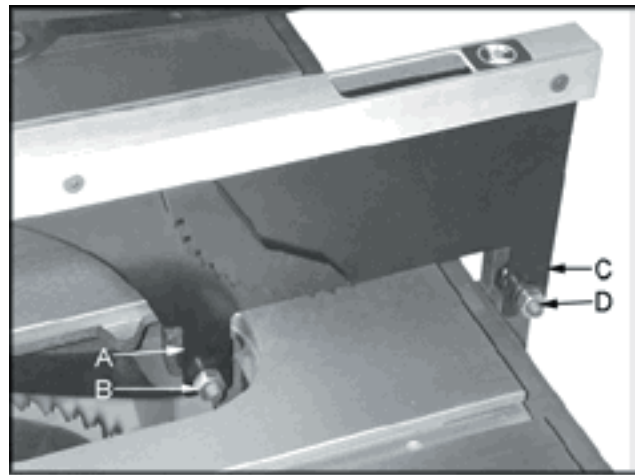

Figure 16

8. Place a straight edge against the splitter and blade to make sure they align, as shown in Figure 17. If adjustment is necessary use the provided wrench to loosen the jam nut (E, Figure 18) on the rear fork. Thread the guard support in, or out by turning the hex head (F, Figure 18) to bring the splitter in line with the blade. Repeat the same procedure for front fork.

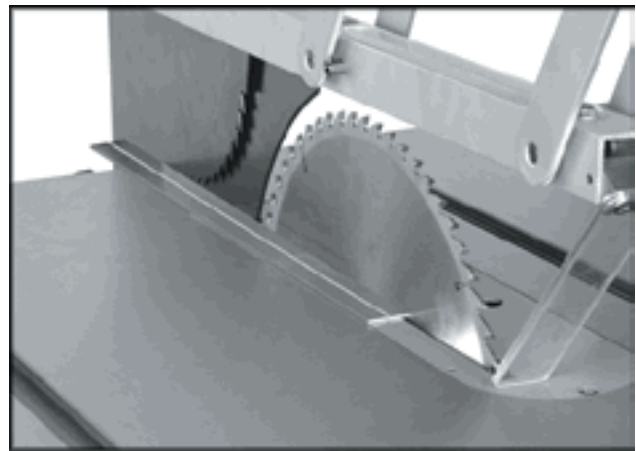

Figure 17

9. Tighten the jam nut (E, Figure 18) and tighten the hex nut (D, Figure 16) with the provided wrenches. Repeat the same procedure for front fork. Recheck the splitter alignment and adjust if necessary.

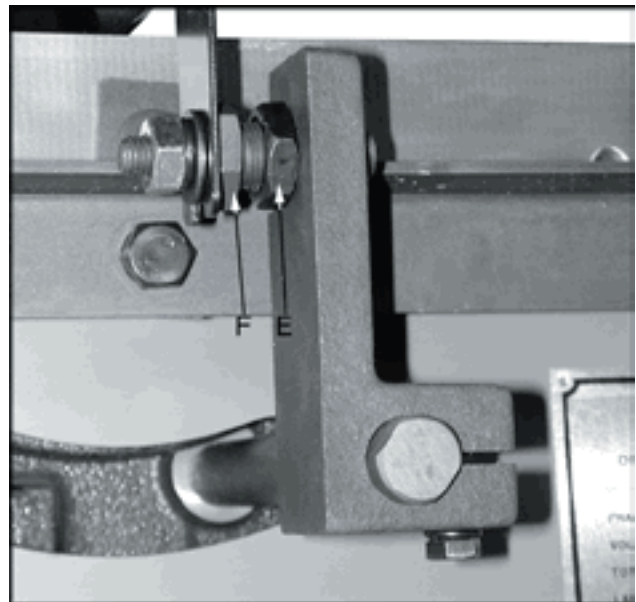

Figure 18

## Miter Gauge

1. Slide the miter gauge bar into the miter gauge slot in table. Loosen the handle (A, Figure 19) and pull out indexing rod (B, Figure 19) to pivot the miter gauge body.
2. Push the indexing rod in to engage the preset stops (C, Figure 19).
3. Adjust stops by loosening the hex nut (D, Figure 19) and adjusting screw (E, Figure 19).

**Note:** Always make test cuts. The scale is for reference. There are two holes in the miter gauge fence used to attach a wooden fence.

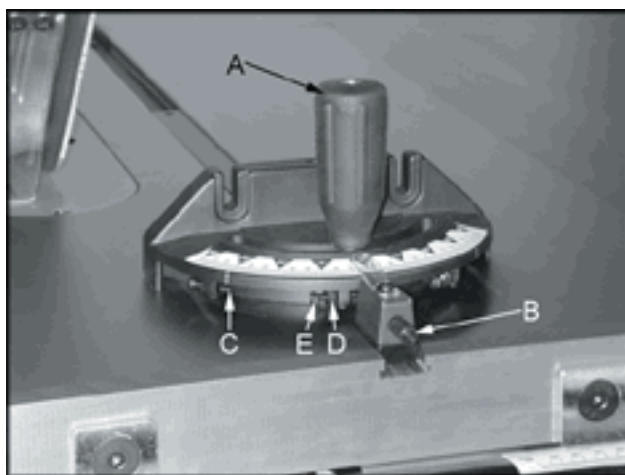

Figure 19

## Controls

- A. Emergency Stop Button:** Stops all functions of machine, but the saw still has power. To reset rotate switch clockwise until the button pops out.
- B. Start:** Starts saw blade rotation. Will not work if the “Emergency Stop” switch is engaged, or the key is in the “OFF” position.
- C. Main Control:** Turn key to the “OFF” position and remove from the lock. The key should be given to a supervisor when the saw is not in use by an authorized user.
- D. Handwheel Lock:** There is a handwheel lock on both handwheels. Loosen lock to turn handwheel and tighten when blade is in desired location.
- E. Raising and Lowering Handwheel:** Loosen handwheel lock. Turn handle clockwise to raise the blade. The blade should be 1/8”-1/4” above the top of workpiece, or 3-5 blade teeth above the top of workpiece.
- F. Tilting Handwheel:** Loosen handwheel lock. Turn handle counter-clockwise to tilt blade to the left.



Figure 20

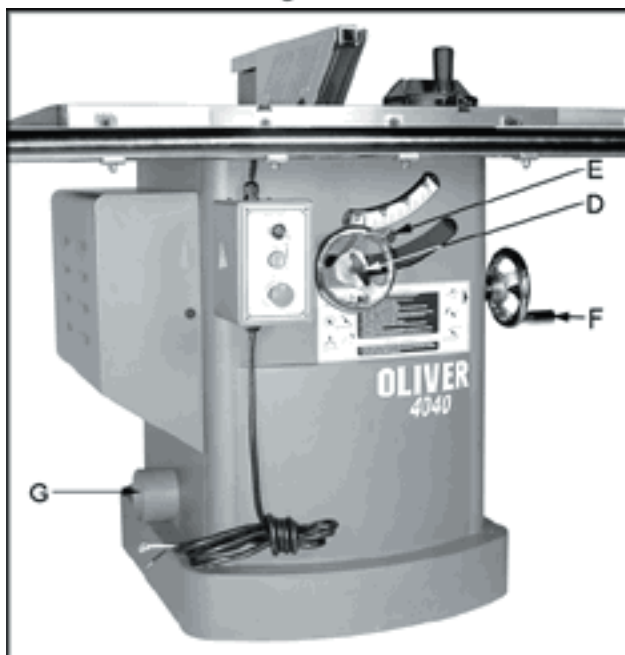

Figure 21

## Dust Collection

There is a 4” dust port (G, Figure 21) located on the side of saw cabinet. Make sure dust collection system has sufficient capacity and suction for your tablesaw. Always turn on dust collection system before starting the tablesaw.

## Electrical Connections

### **WARNING!**

**Electrical connections and wiring must be done by a qualified electrician. The machine must be properly grounded. Failure to comply may cause serious injury!**

This saw is available in both 1-Phase and 3-Phase versions.

#### • **Electrical Connections for a 3-Phase Unit**

This saw is 3-Phase, 220V/440V **pre-wired 220V**. If you need to switch the tablesaw from 220V to 440V have a qualified electrician make the changes. Oliver Machinery recommends using a dedicated circuit.

Make sure the voltage of your power supply matches the specifications on the motor plate of the machine.

With 3-Phase power verify the blade is turning in the proper direction. Turn the saw on and make sure the direction of the blade spins toward the user when standing in front of the saw. If it does not, disconnect the power source and reverse any two power leads.

#### • **Electrical Connections for a 1-Phase Unit**

This saw is 1-Phase, 220V only. Oliver Machinery recommends using a dedicated circuit.

Make sure the voltage of your power supply matches the specifications on the motor plate of the machine.

## Replacing the Blade

The blade guard has been removed for photos, but it is possible to change the blade without removing the blade guard.

1. **Disconnect saw from power source.**
2. Remove the table insert and raise the blade completely.
3. Use the two provided arbor wrenches to loosen the arbor nut, as shown in Figure 22. Place one wrench on the arbor nut and one on the flats located on the arbor. Remove the nut, flange and blade.

4. Replace the blade followed by the flange and arbor nut. Tighten the arbor nut while holding the arbor in place.

**Note:** Make sure the blade and arbor are clean before installing a new blade. The blade teeth should point down when viewing from the front of saw.

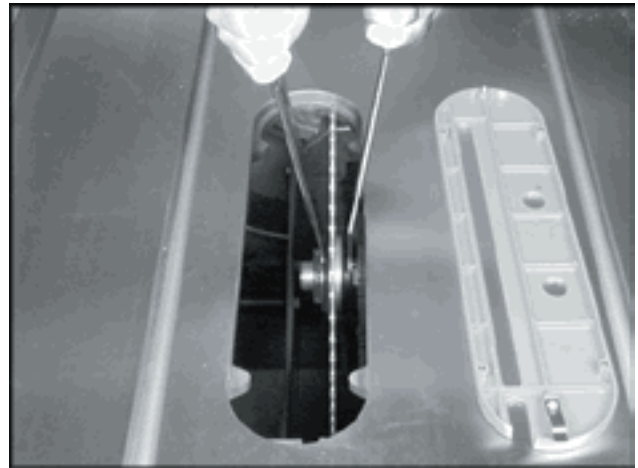

Figure 22

## Changing Arbors

The blade guard has been removed for photos, but it is possible to change the blade without removing the blade guard.

1. **Disconnect saw from power source.**
2. Remove the table insert and raise the blade completely.
3. Use the two provided arbor wrenches to loosen the arbor nut, as shown in Figure 22. Place one wrench on the arbor nut and one on the flats located on the arbor. Remove the nut, flange and blade.
4. Unscrew the socket head cap screw (A, Figure 23) found in the center of the interchangeable arbor while holding the arbor as shown in Figure 23.
5. Remove the interchangeable arbor and replace with a new one. Screw the socket head cap screw (A, Figure 23) into the new arbor, as shown in Figure 24. **Note:** Always clean the mating surfaces before installing the interchangeable arbors.
6. Replace the blade followed by the flange and arbor nut. Tighten the arbor nut while holding the arbor in place.

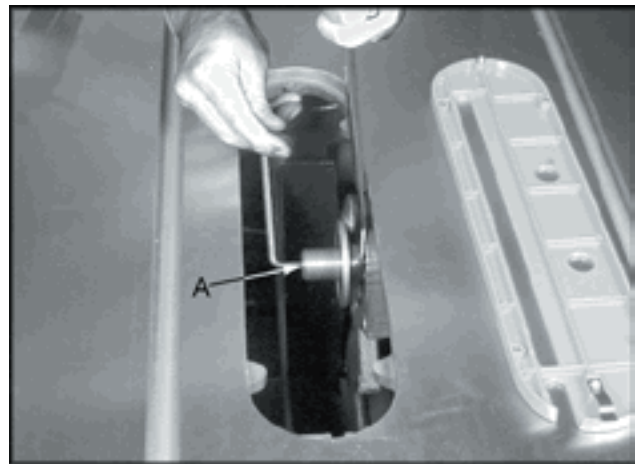

Figure 23



Figure 24

## Replacing and Tensioning V-Belt

1. **Disconnect saw from power source.**
2. Lower the blade to its lowest position and open the motor cover door.
3. Loosen two hex nuts (B, Figure 25).
4. Take tension off of the belts (C, Figure 25) by lifting up on the motor.
5. Remove belts from the arbor and motor pulleys.
6. Replace and tension the belts. The weight of the motor should apply sufficient tension to belts. Tighten the hex nuts (B, Figure 25).
7. Check the belt tension after the saw has been used for a few hours. Adjust as necessary.

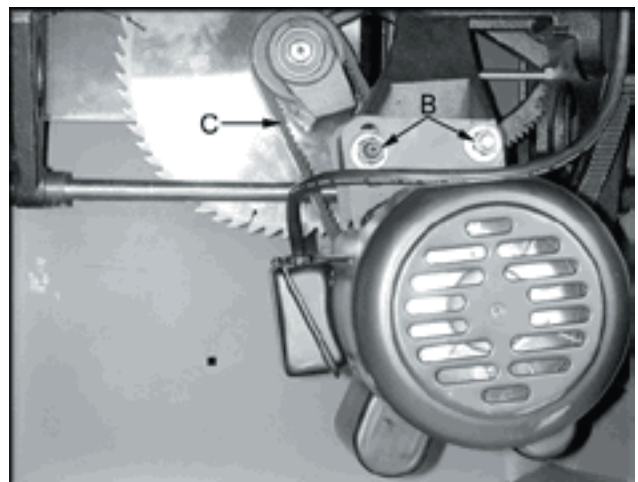

Figure 25

## Maintenance

**⚠ WARNING!**

**Disconnect the machine from power source before proceeding with any maintenance, or troubleshooting! Failure to comply may cause serious injury!**

Periodically clean the inside of the machine for dust control. Use an air hose to blow out dust from motor fan and motor cover.

Use a wire brush to clean trunnions and worm gears. Apply white lithium grease or powdered graphite to lubricate worm gears, and trunnions.

Keep pulleys and belts free from dirt, dust, oil and grease.

Replace worn v-belts as needed.

Remove rust from the tabletop with WD-40 and a Scotch-Brite™ Hand Pad. Keep a light coat of WD-40 on the table top when not in use.

## Troubleshooting

| Description of Symptoms                | Possible Cause   | Corrective Action   |
|--|--|---|
| Machine will not start                 | <ol style="list-style-type: none"> <li>1. Fuse blown or circuit breaker tripped</li> <li>2. Cord Damaged</li> <li>3. Faulty switch</li> <li>4. Not connected to power source</li> <li>5. Connected to wrong voltage</li> <li>6. Key in the "OFF" position</li> <li>7. Emergency stop button pressed</li> </ol> | <ol style="list-style-type: none"> <li>1. Replace fuse or reset circuit breaker</li> <li>2. Have cord replaced</li> <li>3. Replace switch</li> <li>4. Check connection</li> <li>5. Check voltage</li> <li>6. Insert key and turn to "ON" position</li> <li>7. Rotate emergency stop button clockwise until it pops out</li> </ol> |
| Blade does not come up to speed        | <ol style="list-style-type: none"> <li>1. Cable too light or too long</li> <li>2. Low current</li> <li>3. Motor not wired for correct voltage</li> </ol>   | <ol style="list-style-type: none"> <li>1. Replace with adequate size cable</li> <li>2. Contact local electric company</li> <li>3. Refer to motor nameplate for correct voltage</li> </ol>   |
| Does not make accurate 45° or 90° cuts | <ol style="list-style-type: none"> <li>1. Stops not adjusted correctly</li> <li>2. Angle pointer not set accurately</li> <li>3. Miter gauge out of adjustment</li> </ol>   | <ol style="list-style-type: none"> <li>1. Check blade with combination square and adjust stops</li> <li>2. Check blade with combination square and adjust pointer</li> <li>3. Adjust miter gauge</li> </ol>   |
| Saw makes unsatisfactory cuts          | <ol style="list-style-type: none"> <li>1. Dull blade</li> <li>2. Blade mounted backwards</li> <li>3. Gum or pitch on blade</li> <li>4. Incorrect blade for cut</li> </ol>  | <ol style="list-style-type: none"> <li>1. Sharpen or replace blade</li> <li>2. Turn blade around</li> <li>3. Remove blade and clean</li> <li>4. Change blade to correct type</li> </ol>   |
| Material binds blade when ripping      | <ol style="list-style-type: none"> <li>1. Fence not aligned with blade</li> <li>2. Warped wood</li> <li>3. Excessive feed rate</li> <li>4. Splitter not aligned with blade</li> </ol>  | <ol style="list-style-type: none"> <li>1. Check and adjust fence</li> <li>2. Select another piece of wood</li> <li>3. Reduce feed rate</li> <li>4. Align splitter with blade</li> </ol>   |



|                                     |  |  |
|-------------------------------------|--|--|
| Saw vibrates excessively            | <ol style="list-style-type: none"> <li>1. Stand on uneven floor</li> <li>2. Damaged saw blade</li> <li>3. Bad V-belts</li> <li>4. Bent pulley</li> <li>5. Improper motor mounting</li> <li>6. Loose hardware</li> </ol>  | <ol style="list-style-type: none"> <li>1. Reposition on flat, level surface</li> <li>2. Replace saw blade</li> <li>3. Replace V-belts</li> <li>4. Replace pulley</li> <li>5. Check and adjust motor</li> <li>6. Tighten hardware</li> </ol>  |
| Material kicked back from blade     | <ol style="list-style-type: none"> <li>1. Rip fence out of alignment</li> <li>2. Splitter not aligned with blade</li> <li>3. Feeding stock without rip fence</li> <li>4. Splitter not in place</li> <li>5. Dull blade</li> <li>6. Letting go of material before it is past blade</li> <li>7. Anti-kick back paws dull</li> </ol> | <ol style="list-style-type: none"> <li>1. Align rip fence with miter slot</li> <li>2. Align splitter with blade</li> <li>3. Install and use rip fence</li> <li>4. Install and use splitter (with guard)</li> <li>5. Replace blade</li> <li>6. Push material all the way past blade before releasing work</li> <li>7. Replace or sharpen anti-kick back paws</li> </ol> |
| Blade does not raise or tilt freely | Sawdust and debris in raising and tilting mechanisms   | Clean and regrease   |

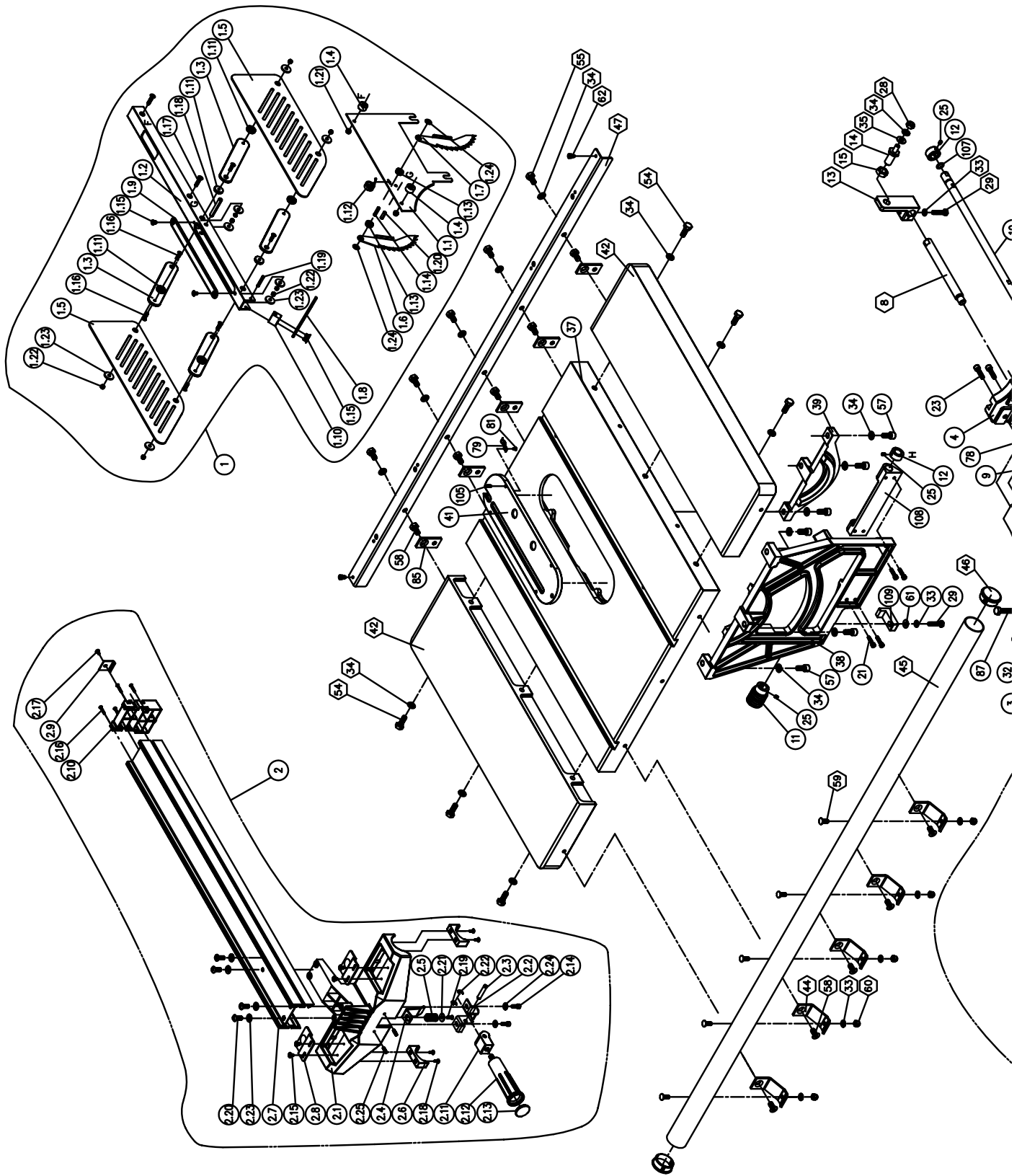



| Sub. No. | Key No. | Part No. | Description                   | Specification | Q'ty |
|----------|---------|----------|-------------------------------|---------------|------|
| 1        |         | TJ0106   | Spreader Ass'y                |               | 1    |
|          | 1.1     | TJ010001 | Spreader                      |               | 1    |
|          | 1.2     | TJ010003 | Guard Bracket                 |               | 1    |
|          | 1.3     | TJ010005 | Bracket - Crank               |               | 4    |
|          | 1.4     | TJ010002 | spacer                        |               | 2    |
|          | 1.5     | TJ010006 | Blade Guard Side              |               | 2    |
|          | 1.6     | TJ010008 | Anti-Kick Pawl L              |               | 1    |
|          | 1.7     | TJ010004 | Anti-Kick Pawl R              |               | 1    |
|          | 1.8     | TJ010007 | Blade Guard Front             |               | 1    |
|          | 1.9     | OE090103 | Top Cover                     |               | 1    |
|          | 1.10    | OE090108 | Guard Front Bracket           |               | 1    |
|          | 1.11    | OE090109 | Collar                        |               | 8    |
|          | 1.12    | TJ010081 | Spring                        |               | 1    |
|          | 1.13    | TH010040 | Fix Collar                    |               | 2    |
|          | 1.14    | TJ010014 | Pin                           |               | 1    |
|          | 1.15    | HA050405 | Flat HD Phil. Bolt            | M6*1.0P*12染黑  | 4    |
|          | 1.16    | HA080310 | Socket HD Bolt                | M5*0.8P*20染黑  | 8    |
|          | 1.17    | HA080412 | Socket HD Bolt                | M6*1.0P*24染黑  | 2    |
|          | 1.18    | HG011232 | spring Pin                    | 8*55          | 1    |
|          | 1.19    | HG011018 | spring Pin                    | 5* 32         | 1    |
|          | 1.20    | HG011111 | spring Pin                    | 6*20          | 1    |
|          | 1.21    | HC040600 | Nylock Nut                    | M6*1.0P染黑     | 2    |
|          | 1.22    | HC040500 | Nylock Nut                    | M5*0.8P染黑     | 8    |
|          | 1.23    | HE012000 | Flat Washer                   | 6.5*23*3t染黑   | 8    |
|          | 1.24    | HF060400 | Push Nut                      | SPN-6         | 2    |
| 2        |         | TJ0107   | Fence Ass'y                   |               | 1    |
|          | 2.1     | TJ010009 | Fence Holder                  |               | 1    |
|          | 2.2     | TJ010010 | Fence Holder Bracket          |               | 1    |
|          | 2.3     | TJ010012 | Shaft                         |               | 1    |
|          | 2.4     | TJ010011 | Clamping Plate                |               | 1    |
|          | 2.5     | TJ010013 | Spring                        |               | 1    |
|          | 2.6     | TJ010015 | Rail Silder                   |               | 2    |
|          | 2.7     | TJ010017 | Fence                         |               | 1    |
|          | 2.8     | TJ010021 | Indicator                     |               | 2    |
|          | 2.9     | TJ010018 | Lock Plate                    |               | 1    |
|          | 2.10    | TJ010020 | Fence End Cap                 |               | 1    |
|          | 2.11    | TJ010022 | Clamping Cam                  |               | 1    |
|          | 2.12    | TJ010023 | Handle                        |               | 1    |
|          | 2.13    | TJ010024 | Handle Cap                    |               | 1    |
|          | 2.14    | HA020406 | Round HD Phil. Screw          | M6*1.0P*16染黑  | 2    |
|          | 2.15    | HA260400 | Round HD Phil. Screw w/washer | M5*0.8P*10染黑  | 4    |
|          | 2.16    | HA180313 | Round HD Phil. Screw          | M4*1.59P*25染黑 | 4    |
|          | 2.17    | HA180405 | Round HD Phil. Screw          | M5*2.12P*12染黑 | 1    |

|    |      |          |                        |                   |   |
|----|------|----------|------------------------|-------------------|---|
|    | 2.18 | HA180304 | Round HD Phil. Screw   | M4*1.59P*10染黑     | 4 |
|    | 2.19 | HA090410 | Round HD Socket Screw  | M6*1.0P*20染黑      | 1 |
|    | 2.20 | HA090510 | Round HD. Socket Screw | M8*1.25P*20染黑     | 4 |
|    | 2.21 | HE012600 | Flat Washer            | 6.7*19*1t染黑       | 1 |
|    | 2.22 | HF031600 | E-RING                 | ETW-7             | 2 |
|    | 2.23 | HE014100 | Spring Washer          | 8.8*18*2t染黑       | 4 |
|    | 2.24 | HE012500 | Flat Washer            | 6.7*16*2t染黑       | 2 |
|    | 2.25 | HA030405 | Set Screw              | M6*1.0P*12染黑      | 2 |
| 3  |      | th0303   | Miter Guage Ass'y      |                   | 1 |
|    | 3.1  | HB040807 | Rounf HD Phil. Screw   | 5/32-32NC*5/8"染黑  | 3 |
|    | 3.2  | HB040905 | Rounf HD Phil. Screw   | 3/16"-24NC*3/8"染黑 | 3 |
|    | 3.3  | HD010200 | Hex HD Bolt            | 5/32"-32NC* 染黑    | 3 |
|    | 3.4  | HT051003 | Flat HD Phil. Bolt     | 1/4"-20NC*1/4" 電鍍 | 1 |
|    | 3.5  | HY013700 | Flat Washer            | 8.5*18*3T 電鍍      | 1 |
|    | 3.6  | HR043000 | Poly bag               | 560*210*0.1T      | 1 |
|    | 3.7  | TH030301 | Handle                 |                   | 1 |
|    | 3.8  | TH030304 | Miter Guage            |                   | 1 |
|    | 3.9  | TH010303 | Miter Scale            |                   | 1 |
|    | 3.10 | TH010304 | Indicator              |                   | 1 |
|    | 3.11 | TH010305 | Bracket                |                   | 1 |
|    | 3.12 | TH030106 | Position Pin           |                   | 1 |
|    | 3.13 | TH030302 | Slider                 |                   | 1 |
|    | 3.14 | TH010308 | Shoulder Screw         |                   | 1 |
|    | 3.15 | TH030303 | Spacer                 |                   | 1 |
|    |      |          |                        |                   |   |
| 4  |      | TJ010026 | Trunnion Bracket       |                   | 1 |
| 5  |      | TJ010027 | Suspension             |                   | 1 |
| 6  |      | TJ010028 | Suspension Plate       |                   | 1 |
| 7  |      | TJ010030 | Blade Guard            |                   | 1 |
| 8  |      | TJ010031 | Support Shaft          |                   | 1 |
| 9  |      | TJ010032 | Support Bracket        |                   | 1 |
| 10 |      | TJ010034 | Height Adjustment Rod  |                   | 1 |
| 11 |      | TJ010035 | Warm Shaft             |                   | 2 |
| 12 |      | TJ010036 | Bushing                |                   | 4 |
| 13 |      | TJ010037 | Adjust Block           |                   | 1 |
| 14 |      | TJ010038 | Adjustment Shaft       |                   | 2 |
| 15 |      | HC011500 | Hex Nut                | M10*1.5P染黑        | 2 |
| 16 |      | TJ010041 | Key                    |                   | 2 |
| 17 |      | TJ010043 | Indicator              |                   | 1 |
| 18 |      | TJ0103   | Rod Lock Ass'y         |                   | 2 |
|    |      | TJ010301 | Screw                  |                   | 1 |
|    |      | TJ010302 | Rod Lock Handle        |                   | 1 |
| 19 |      | TJ010039 | Hand Wheel             |                   | 2 |
| 20 |      | HA010405 | Hex HD Bolt            | M6*1.0P*12染黑      | 2 |

|    |  |          |                     |                  |    |
|----|--|----------|---------------------|------------------|----|
| 21 |  | HA020413 | SKT. HD. Bolt       | M6*1.0P*25染黑     | 6  |
| 22 |  | HG011111 | Spring Pin          | 6*20             | 4  |
| 23 |  | HA020513 | SKT. HD. Bolt       | M8*1.25P*25染黑    | 10 |
| 24 |  | HA030304 | Set Screw           | M5*0.8P*10 染黑    | 6  |
| 25 |  | HA030303 | Set Screw           | M5*0.8P*8染黑      | 6  |
| 26 |  | HA040602 | RD HD Bolt          | M5*0.8P*6 染黑     | 1  |
| 27 |  | HH030415 | Key Way             | 5*5*30           | 2  |
| 28 |  | HW011000 | Hex Nut             | M10*1.5P 電鍍      | 6  |
| 29 |  | HA010519 | Hex HD Bolt         | M8*1.25P*35染黑    | 2  |
| 30 |  | HA010647 | Hex HD Bolt         | M10*1.5P*80電鍍    | 1  |
| 31 |  | HS010613 | Hex HD Bolt         | M10*1.5P*25電鍍    | 1  |
| 32 |  | HS010628 | Hex HD Bolt         | M10*1.5P*50電鍍    | 1  |
| 33 |  | HE021100 | Spring Washer       | 8.2*15.4*2t染黑    | 7  |
| 34 |  | HE021300 | Spring Washer       | 10.2*18.5*2.5t染黑 | 22 |
| 35 |  | HE016200 | Flat Washer         | 10.3*22*2.0t 染黑  | 2  |
| 36 |  | HG011017 | spring Pin          | 5*30             | 2  |
| 37 |  | TJ010046 | Table               |                  | 1  |
| 38 |  | TJ010047 | Bevel Bracket Front |                  | 1  |
| 39 |  | TJ010048 | Bevel Bracket Rear  |                  | 1  |
| 40 |  | TJ010049 | Bevel Rod           |                  | 1  |
| 41 |  | TJ010050 | Throat Plate        |                  | 1  |
| 42 |  | TJ010051 | Extension Wing      |                  | 2  |
| 43 |  | TJ010052 | Bevel Rod Seat      |                  | 1  |
| 44 |  | TJ010053 | Rail Holder         |                  | 5  |
| 45 |  | TJ010054 | Rail Front          |                  | 1  |
| 46 |  | TJ010055 | Rail Front End Cap  |                  | 2  |
| 47 |  | TJ010057 | Rear Rail           |                  | 1  |
| 48 |  | TJ010058 | Arbor Wrench        |                  | 2  |
| 49 |  | TJ010071 | Spreader Wrench     |                  | 2  |
| 50 |  | TJOB     | Switch Ass'y        |                  | 1  |
| 51 |  | TJ010201 | Cabinet             |                  | 1  |
| 52 |  | TJ010202 | Side Cover          |                  | 1  |
| 53 |  | PJ010018 | Wheel Handle        |                  | 2  |
| 54 |  | HA010616 | Hex HD Bolt         | M10*1.5P*30染黑    | 6  |
| 55 |  | HA010610 | Hex HD Bolt         | M10*1.5P*20染黑    | 8  |
| 56 |  | HA040705 | RD HD Bolt          | M6*1.0P*12染黑     | 2  |
| 57 |  | HA010619 | Hex HD Bolt         | M10*1.5P*35染黑    | 6  |
| 58 |  | HA080608 | Flat HD Socket Bolt | M10*1.5P*16 電鍍   | 10 |
| 59 |  | HS110508 | Carriage Bolt       | M8*1.25P*16電鍍    | 5  |
| 60 |  | HW020700 | Hex Nut             | M8*1.25P電鍍       | 5  |
| 61 |  | HE014400 | Flat Washer         | 8.5*19*2t染黑      | 1  |
| 62 |  | HA020404 | SKT. HD Bolt        | M6*1.0P*10染黑     | 2  |
| 63 |  | TJ010063 | Saw Blade           |                  | 1  |
| 64 |  | TJ010064 | Flange              |                  | 1  |
| 65 |  | TJ010066 | Pulley              |                  | 1  |

|     |        |           |                   |                    |   |
|-----|--------|-----------|-------------------|--------------------|---|
| 66  |        | TJ010061  |                   |                    | 1 |
| 67  |        | TJ010067  | Shaft             |                    |   |
| 68  |        | TJ010068  | 1" Blade Nut      |                    |   |
| 69  |        | TJ010069  | Motor Bracket     |                    |   |
| 70  |        | TJ010072  |                   |                    | 1 |
| 71  |        | TJ010073  | 1" Arbor          |                    | 1 |
| 72  |        | TJ010074  | 5/8" Arbor        |                    | 1 |
| 73  |        | TJ010075  | 5/8" Arbor Nut    |                    | 1 |
| 74  |        | TJ010077  | Blade Washer      |                    | 1 |
| 75  |        | TJOA      |                   |                    | 1 |
| 76  |        | HA020450  | SKT. Cap Bolt     | M6*1.0P*65 染黑      | 1 |
| 77  |        | HA020537  | SKT. Cap Bolt     | M8*1.25P*65 染黑     | 2 |
| 78  |        | HG010911  | spring Pin        | 4*20               | 2 |
| 79  |        | TJ010084  | Throat Plate Clip |                    | 1 |
| 80  |        | HF023700  | R-Ring            | RTW-47             | 1 |
| 81  |        | HA040402  | RD HD Bolt        | M4*0.7P*6染黑        | 1 |
| 82  |        | HH010422  | Key Way           | 5*5*38             | 1 |
| 83  |        | HJ032100  | Bearing           | 6203-2NSE          | 1 |
| 84  |        | HJ031000  | Bearing           | 6005-2NSE          | 1 |
| 85  |        | TJ010087  | Connect           |                    | 5 |
| 86  |        | HF011500  | S-Ring            | STW-17             | 1 |
| 87  |        | HS010640  | Hex HD Bolt       | M10*1.5P*70 電鍍     | 1 |
| 88  |        | TJ010025  | Trunnion          |                    | 1 |
| 104 |        | HF011800  | S-Ring            | STW-20             | 1 |
| 105 |        | HA030405  | Set Screw         | M6*1.0P*12染黑       | 4 |
| 106 |        | HS121060  | Screw             | M12*1.75P*220 Plat | 2 |
| 107 |        | HM081200  | O- Ring           | P14                | 4 |
| 108 |        | TJ010045  | Bearing Seat      |                    | 1 |
| 109 |        | TJ010044  | Fix Block         |                    | 1 |
| 110 |        | TJ010080  | Bevel Scale       |                    | 1 |
| 111 |        | HF012300  | S-Ring            | STW-25             | 2 |
| 112 |        | HS040403  | RD HD Bolt        | M4*0.7P*8 染黑       | 2 |
| 113 |        | HA040604  | RD HD Bolt        | M5*0.8P*6 染黑       | 2 |
| 114 |        | TJ010082  |                   |                    | 1 |
| 115 |        | TJ0112    |                   |                    | 1 |
|     | 115.1  | TJ010031  |                   |                    | 1 |
|     | 115.2  | HR023100  | 250*260*0.05t     |                    | 1 |
|     | 115.3  | TJ010037  |                   |                    | 1 |
|     | 115.4  | HC011500  | M16*1.5P染黑        |                    | 1 |
|     | 115.5  | TJ010038  |                   |                    | 1 |
|     | 115.6  | HE016200  | 10.3*22*2.0t染黑    |                    | 1 |
|     | 115.7  | HE0121300 | 10.2*18.5染黑       |                    | 1 |
|     | 115.8  | HW011000  | M10*1.5P電鍍        |                    | 1 |
|     | 115.9  | HE021100  | 8.2*15.4染黑        |                    | 1 |
|     | 115.10 | HA010519  | M8*1.25P*35染黑     |                    | 1 |