



Model 10047 Spindle Shaper Owner's Manual



Table of contents

READ CAREFULLY BEFORE OPERATING THE MACHINE	2
Safety Rules	4
Installing	5
Cleaning.....	5
Lock Handle Assembly.....	5
Fence Assembly Installation.....	6
Cutter Guard	6
Feather Board	6
General Information	6
Extension Cords.....	6
Adjustment.....	7
Fence Assembly Movement	7
Handwheel	7
Coplanar Alignment.....	8
Fence perpendicular to table	9
Ram Dial Calibration	9
Spindle Gib Adjustment.....	10
Featherboard Hold-downs.....	10
Spindle Assembly Installation.....	11
Spindle Assembly Removal.....	12
Shaper Cutter Installation	12
Changing Spindle Speed.....	13
Belt Replacement.....	13
Drive Belt Tension	13
Precision Miter Gauge.....	14
Switch	14
Operations	15
Overview	15
Safety Devices	15
Grain Direction Considerations.....	15
Cutter Rotation	15
Using the Fence	16
"Z" Dimension	16
Depth of Cut.....	17
Special Cuts.....	23
Troubleshooting	26
Wiring Diagrams	28
Exploded View	29
Parts List.....	35

READ CAREFULLY BEFORE OPERATING THE MACHINE

KEEP GUARDS IN PLACE and in working order.

REMOVE ADJUSTING KEYS AND WRENCHES. Form habit of checking to see that keys and adjusting wrenches are removed from tool before turning it on .

KEEP WORK AREA CLEAN. Cluttered areas and benches invite accidents.

DON'T USE IN DANGEROUS ENVIRONMENT. Don't use power tools in damp or wet locations, or expose them to rain. Keep work area well lighted.

KEEP CHILDREN AWAY. All visitors should be kept safe distance from work area.

MAKE WORKSHOP KIDS PROOF with padlocks, master switches, or by removing starter keys.

DON'T FORCE TOOL. It will do the job better and safer at the rate for which it was designed.

USE RIGHT TOOL. Don't force tool or attachment to do a job for which it was not designed.

WEAR PROPER APPAREL. Do not wear loose clothing, gloves, neckties, rings, bracelets, or other jewelry which may get caught in moving parts. Nonslip footwear is recommended. Wear protective hair covering to contain long hair.

ALWAYS USE SAFETY GLASSES. Also use face or dust mask if cutting operation is dusty. Everyday eyeglasses only have impact resistant lenses, they are NOT safety glasses.

SECURE WORK. Use clamps or a vise to hold work when practical. It's safer than using your hand and it frees both hands to operate tool.

DON'T OVERREACH. Keep proper footing and balance at all times.

MAINTAIN TOOLS WITH CARE. Keep tools sharp and clean for best and safest performance. Follow instructions for lubricating and changing accessories.

DISCONNECT TOOLS before servicing; when changing accessories, such as blades, bits, cutters, and the like.

REDUCE THE RISK OF UNINTENTIONAL STARTING. Make sure switch is in off position before plugging in.

USE RECOMMENDED ACCESSORIES. Consult the owner's manual for recommended accessories. The use of improper accessories may cause risk of injury to persons.

NEVER STAND ON TOOL. Serious injury could occur if the tool is tipped or if the cutting tool is unintentionally contacted.

CHECK DAMAGED PARTS. Before further use of the tools, a guard or other part that is damaged should be carefully checked to determine that it will operate properly and perform its intended function – check for alignment of moving parts, binding of moving parts, breakage of parts, mounting , and any other conditions that may affect its operation. A guard or other part that is damaged should be properly repaired or replaced.

DIRECTION OF FEED. Feed work into a blade or cutter against the direction of rotation of the blade or cutter only.

NEVER LEAVE TOOL RUNNING UNATTENDED. TURN POWER OFF. Don't leave tool until it comes to a complete stop.

READ CAREFULLY BEFORE OPERATING THE MACHINE

Wear eye protection.

Be sure keyed washer is directly under spindle nut and spindle nut is right.

Feed work piece against rotation of cutter.

Do not use awkward hand positions.

Keep fingers away from revolving cutter – use fixtures when necessary.

Use overhead guard when adjustable fence is not in place

Follow local regulations and National Electrical Code, ANSI/NFPA 70 installation requirements in installing the tool.

This tool should be connected to a grounded metal permanent wiring system ; or to a system having an equipment-grounding conductor.

Familiarize yourself with the following safety notices used in this manual:

Warning : This is means that if precautions are not heeded, it may result in serious injury or possibly even death.

Safety Rules

Short stock – Never shape stock less than 12 Inches in length without special fixtures. Where practical, shape longer stock and cut to size.

12 inch rule – When shaping, never allow your hands to come closer than 12 inches to the cutters.

Hand safety – Never pass the hands directly over, or in front of, the cutters (Fig. A). As one hand approaches the 12 inch radius point, remove it (or the push stick) in an arc motion and reposition hands 12 inches beyond the cutters. Blind cut – When blind cutting, the workpiece is positioned on top of the template.

This keeps the cutter(s) cutting only the underside of the workpiece and provides a "distance" guard for the operator.

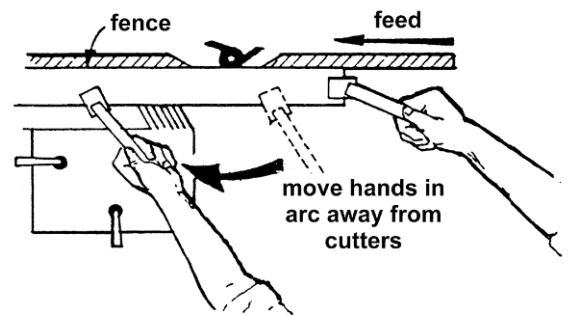

Fig. A

Cutter Clearance – With the power disconnected, always rotate the spindle by hand with any new set-up to ensure proper clearance with the cutters. At the same time, check to be sure the cutterhead is turning in the correct direction.

Stock feed – Feed stock opposite to the direction of the cutter rotation (Fig. B). Never back stock out of the cutter once the cut has been started. Instead, pull the stock straight out away from the cutter and begin the cut again.

Guide pin – Whenever possible, use a guide pin when performing pattern shaping and collar shaping operations.

Tool maintenance – Clean and sharp tools give safer and better performance. Dull tools can cause kickbacks and excessive chatter. Before making a cut, always check the condition and adjustment of the tools. Never use a tool that is not balanced and rated for the selected RPM.

Spindle speed – Do not operate tools at speeds higher than rated by the manufacturer.

Cutter selection – Use only those cutters designed to be used on the machine, and mount only safety type cutters on the spindle.

Stock condition – The danger of kicked-back stock can occur when the stock has knots, holes, or foreign objects such as nails. Warped or in-wind stock should first be jointed on one surface before attempting to use it on the shaper.

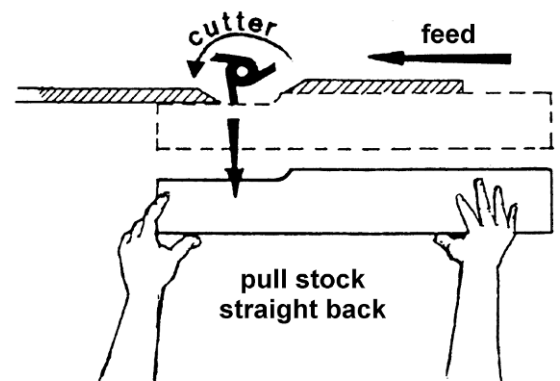

Fig. B

Installing

1. Unbolt the shaper from the skid.
2. Carefully slide the shaper from the pallet onto the floor.

Caution: Make sure that the casters do not get damaged when removing from the skid.

The Shaper should be placed in an area with a sturdy level floor, good ventilation and sufficient lighting. Leave enough space around the machine for mounting extension wings rail assembly, loading, off-loading stock and general maintenance work.



Cleaning

1. Remove two hex cap screws and flat washers(A) that secure the fence assembly (B) to the table and discard (Fig. 1)
2. Set the fence assembly (B) aside to permit cleaning of the table.
3. Take off the plastic protective wrap covering the table surface.
The Table top and extension wings , have been given a protective coating at the factory.
4. Remove protective coating with a soft cloth moistened with kerosene.
Do not use acetone, gasoline, or lacquer thinner for this purpose. Do not use solvents on plastic parts, and do not use an abrasive pad because it may scratch the surfaces.

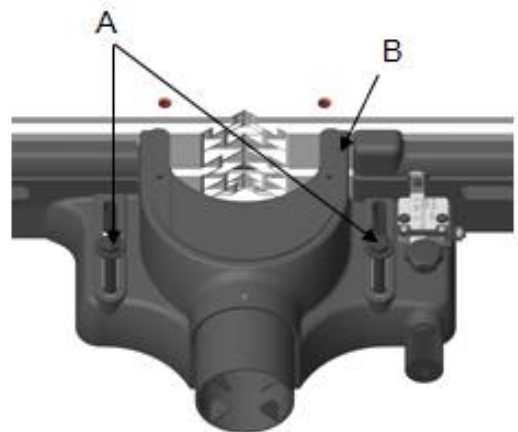

Fig. 1

Lock Handle Assembly

1. Locate two fence locks from the hardware package and disassemble Fig.2
2. Place the washers (E) on the shaft of each lock handle (D), then insert into the slotted openings (O) on the fence casting (P).
3. Continue the lock handle re-assembly by placing one washer (E) then through the slotted opening (O) on the fence casting(P) and tighten all the way by hand.

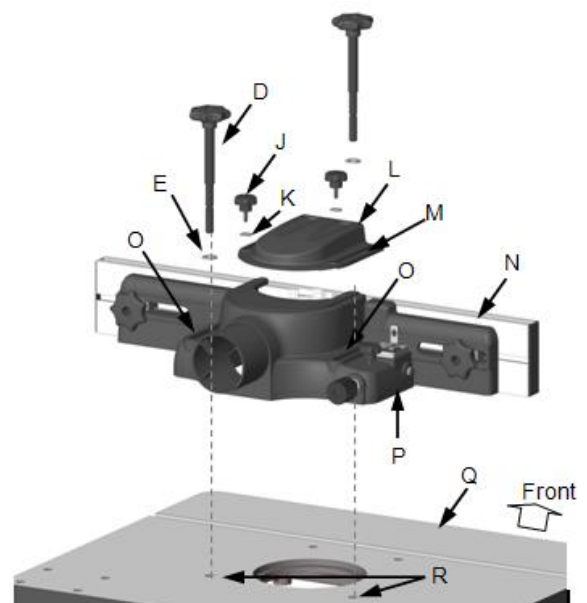

Fig. 2

Fence Assembly Installation

1. Place the fence assembly (N) on the table (Q).
2. Line up the threaded ends of the lock handles (D) with the threaded mounting holes (R) on the table (Q) and secure, but allow sufficient slack to permit the fence to be adjusted backward and forward.
3. Place the safety guard holder (L) on the casting (P) and secure with lock knobs (J) and flat washers (K).

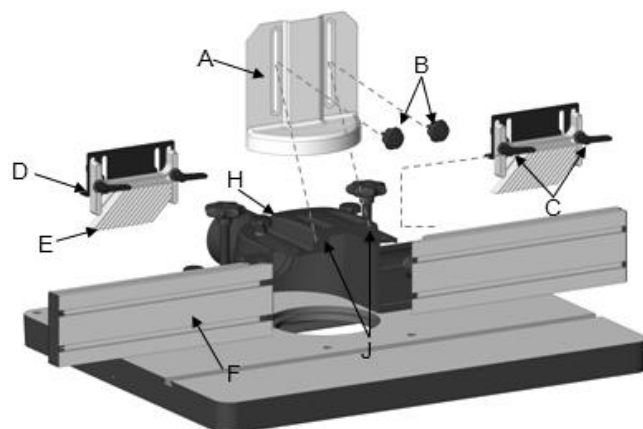

Fig. 3

Cutter Guard

Mount the cutter guard (A) Fig. 3 to the safety guard holder (H). Insert two lock knobs (B) through the cutter guard slots and into the threaded mounting holes (J) on the safety guard holder (H).

Feather Board

Loosen lock handles (C) Fig. 3 and slide the rail of the featherboard so the squared edges of the carriage bolt (D) engages in the groove (F) along the top of the fence.

General Information

A power plug is not provided with this sharper. You may either connect the proper UL/CSA listed plug or "hardwire" the machine directly to your electrical panel provided there is a disconnect near the machine for the operator. Consult electrical drawings for further clarification of wiring setup.

This machine must be grounded. Grounding provides a path of least resistance to help divert current away from the operator in case of electrical malfunction.

Make sure the voltage of your power supply matches the specifications on the motor plate of the machine.

Extension Cords

If an extension cord is necessary, make sure the cord rating is suitable for the amperage listed on the machine's motor plate. An undersize cord will cause a drop in line voltage resulting in loss of power and overheating.

The chart in Fig.5 shows the correct size cord to use based on cord length and motor plate amp rating. If in doubt, use the next heavier gauge. The smaller the gauge number, the heavier the cord.

Amps	Extension Cord Length *					
	25 feet	50 feet	75 feet	100 feet	150 feet	200 feet
< 5	16	16	16	14	12	12
5 to 8	16	16	14	12	10	NR
8 to 12	14	14	12	10	NR	NR
12 to 15	12	12	10	10	NR	NR
15 to 20	10	10	10	NR	NR	NR
21 to 30	10	NR	NR	NR	NR	NR

*based on limiting the line voltage drop to 5V at 150% of the rated amperes.

NR: Not Recommended.

Adjustment

Fence Assembly Movement

The adjustment controls of the fence assembly are as follows (Fig. 4):

- A – Fence Assembly Lock Knob – to secure fence assembly to table
- B – Lock Knob – to secure the outfeed fence
- C – Outfeed Ram Adjust – fine forward/backward adjustment for outfeed fence
- D – Lock Knob – loosening permits side to side adjustment of infeed or outfeed fence
- E – Lock Knob – loosening permits vertical adjustment of guard (F)
- G – Lock Knob – loosening permits backward/forward adjustment of guard (F)

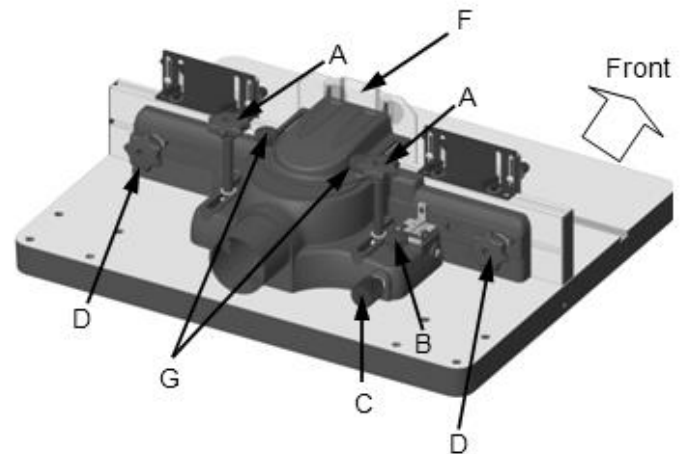

Fig. 4

Handwheel

The handwheel controls the spindle height.

Spindle height

1. Loosen the lock knob A (Fig. 5)
2. Turn the handwheel B clockwise to raise and counterclockwise to lower the Spindle C.
3. Tighten the lock knob A.

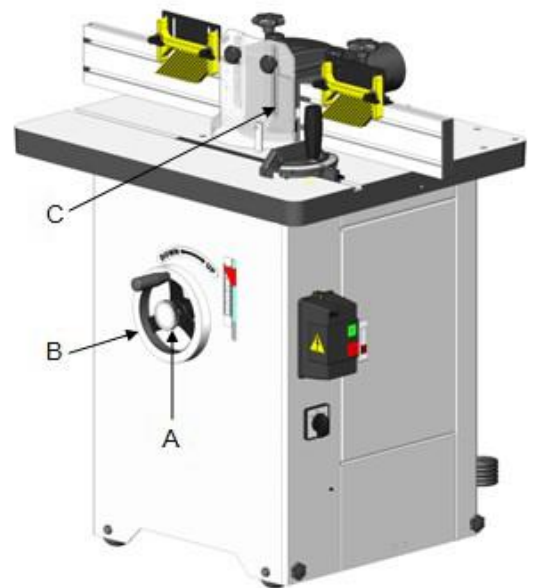

Fig. 5

Coplanar Alignment

Follow steps 1–5 to determine if alignment is necessary. Steps 8–11 will guide you through the alignment if required.

Verifying that fences are coplanar

1. Remove the guard and spindle attachment.
2. Unlock knobs D1, D2 and adjust the fence assembly (A) so it is positioned approximately at midpoint; then secure lock knobs D1, D2.
3. Place a straightedge (H) on the table against the infeed and outfeed fences (F1, F2).
4. Unlock the ram dial lock knob (B)
5. With the ram adjust dial (C) the adjust position of the outfeed fence (G2) while at the same time pressing against the straightedge (H) and attempting to bring both fences (G1, G2) in-line with the straightedge.

Note: The outfeed fence casting (F2) is adjustable while the infeed fence casting (F1) is stationary and cannot be adjusted.

No adjustment is required if both fences (G1, G2) are flush with the straightedge as shown in Fig. 8. Proceed to the Ram Dial Calibration section on page 10.

Adjustment is required if the fences appear skewed (Fig. 9). Continue with the steps below.

Coplanar Adjustment

6. Remove both fences (J1, J2) and place the straightedge against the infeed and outfeed fence castings (Fig. 10).

Coplanar Alignment

Read step 7 completely before attempting.

7. Maintain steady pressure of the straightedge against the fence castings (K, Fig. 10). At the same time, attempt to bring both fences into alignment as shown in Fig. 11. This is accomplished by alternately making incremental adjustments to two setscrews (M, Fig. 12) on the front face of the casting (L, Fig. 12) with a 3mm hex wrench, followed by repositioning the casting with the ram adjust dial (Q, Fig. 12) as required.

Important: It is recommended that the adjustment setscrews (M, Fig. 12) be rotated in 1/16th increments or less at a time.

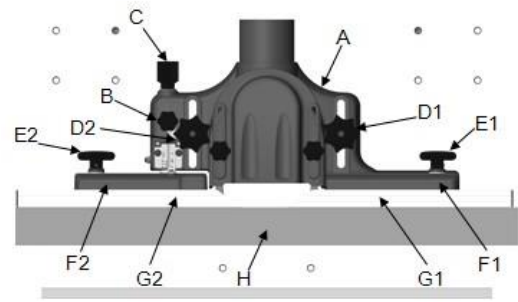

Fig. 6

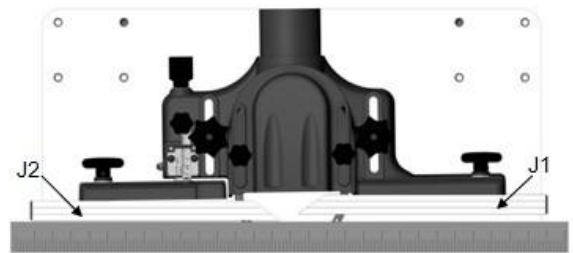

Fig. 7

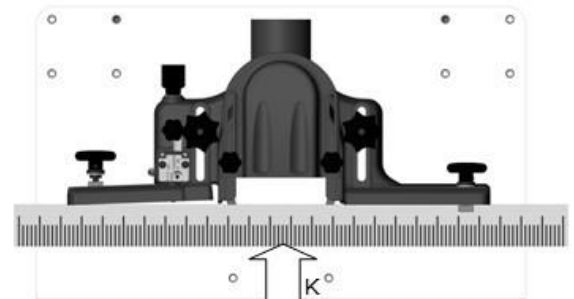

Fig. 8

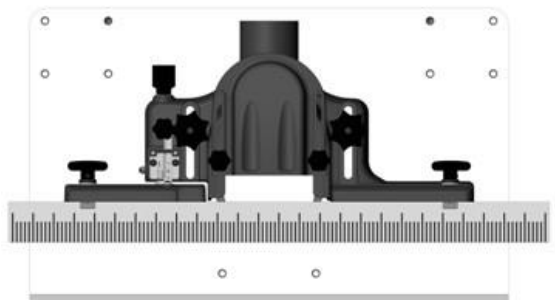

Fig. 9

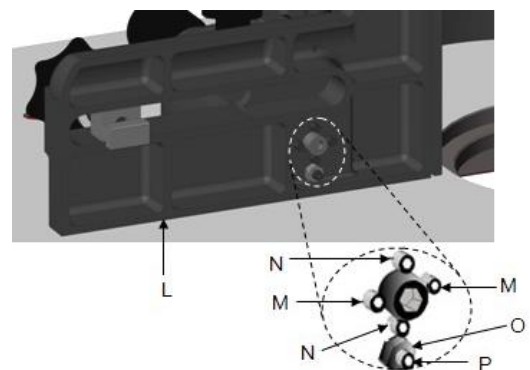

Fig. 10

Fence perpendicular to table

The outfeed fence must also be perpendicular to the table. This can be checked as follows:

- Place a square against the casting (L, Fig. 10) and table.
- If adjustment is required, adjust setscrews N (Fig. 10).

Alignment is complete when both fence castings are coplanar (in-line) as shown in Fig. 9 and the outfeed fence is perpendicular to the table.

- Replace both fences and secure.

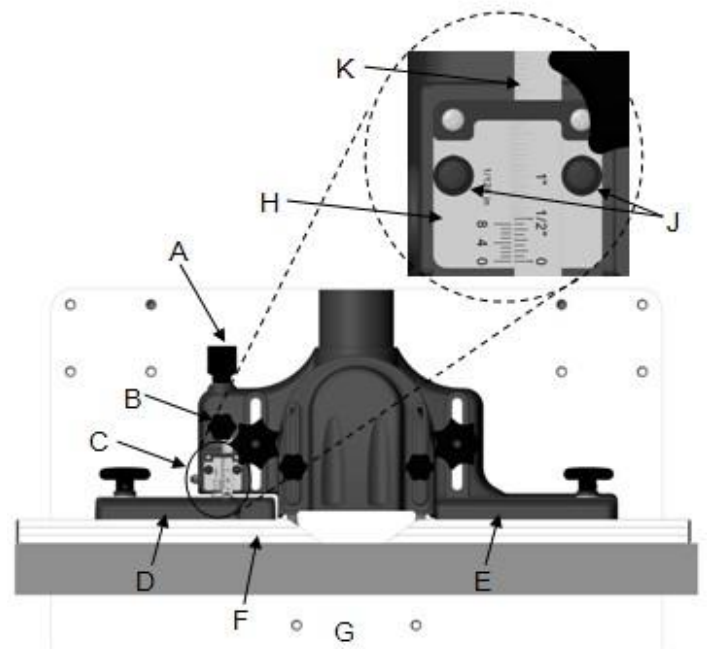

Ram Dial Calibration

The cutter guard should be removed or raised to provide clearance (Fig. 11).

- Loosen the ram dial lock knob (B).
- Adjust the outfeed ram dial (A) fully clockwise.
- With a straightedge (F) pressed against both infeed and outfeed fences (D, E, G) as reference, both fences should be in-line as shown and the scale (C) should indicate zero.

If step 3 can be successfully achieved, no calibration is required.

If the fences cannot be brought into alignment (L), adjust as follows:

- Remove fences (D, E).
- Using a 10mm wrench, loosen the lock nut (O, Fig.10) that secures the zero stop set-screw (P, Fig. 12) on the casting (L, Fig. 10).
- Loosen or tighten the setscrew (P, Fig.10), as required, to bring fence castings into alignment as shown in M.

Note: Ram Dial Adjust (A) is fully clockwise (from step 2).

- Tighten lock nut (O, Fig. 10).

If the scale (C) does not indicate zero:

- Loosen two screws (J) that secure the indicator (H) and adjust until the zero on the indicator (H) is lined up with the zero on the scale (K).
- Tighten screws (J).

Repeat steps 2 and 3 to verify that calibration is successful.

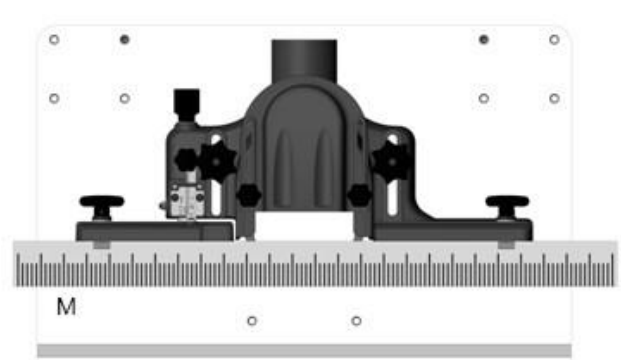
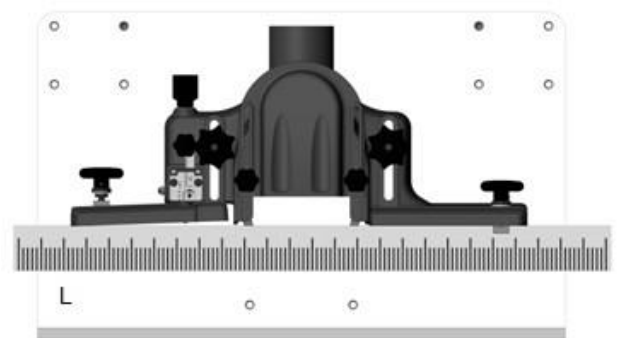

Fig. 11

Spindle Gib Adjustment

The spindle housing gib on your machine is factory adjusted and initially should not require readjustment. After a period of use the gib may wear and become loose, introducing play and potentially causing the spindle (B) to vibrate. This requires adjustment (Fig. 12).

To adjust:

1. With a 12mm wrench, loosen jam nuts that secure the gib setscrews in four places (A).
2. With a 4mm hex wrench, tighten each set screw 1/8 or less turn starting with the lowest one, followed by the uppermost one, then the two middle setscrews.

If this is not enough to remove the play, repeat this step until the play is removed.

Note: If the gibs are too tight the front handwheel that controls the spindle height will be difficult to turn.

When adjustment is complete:

3. Hold the set-screws in position with the 4mm hex wrench to maintain the setting while tightening the jam nuts with the 12mm wrench.

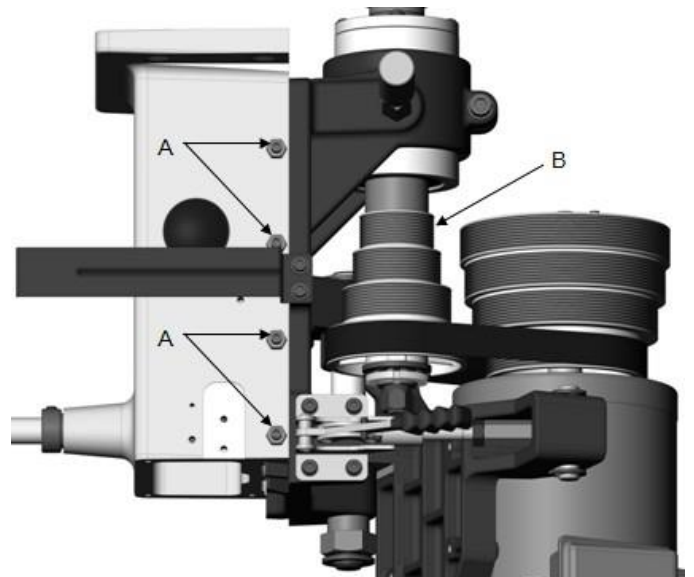

Fig. 12

Featherboard Hold-downs

This Sharper comes equipped with two featherboard hold-downs (A, B) mounted on the infeed and outfeed fences.

1. Loosen lock handles (C) and lock knobs (D).
2. Slide the hold-down guides to the desired position along the fence and tighten the lock handles (C).
3. Place the workpiece (E) on the table against the fence and under the hold-down guide (A).
4. Adjust the featherboard stay to put moderate pressure on the workpiece, then tighten the lock knob (D).

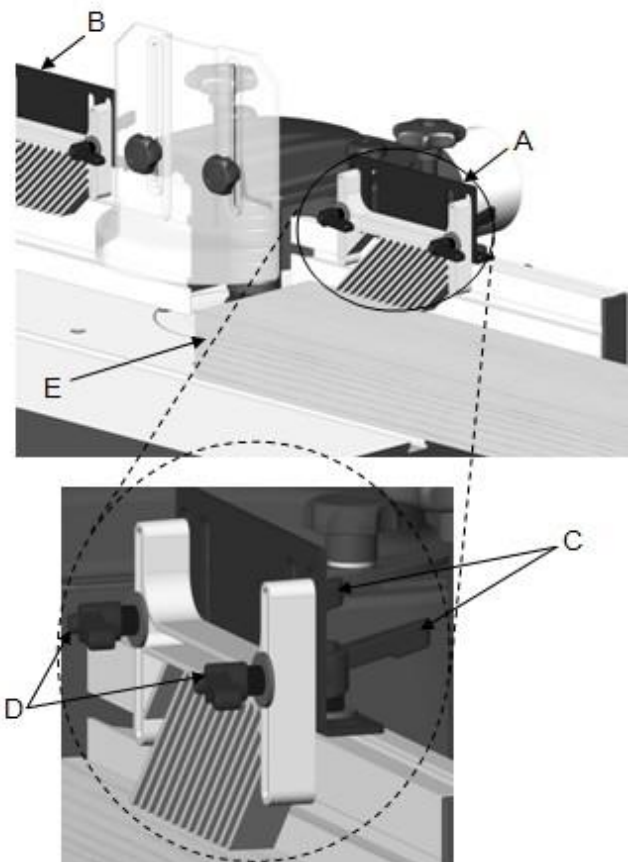

Fig. 13

Spindle Assembly Installation

The spindle assembly (B) is mounted to the arbor (H) and secured with a draw bar (O) and spindle nut (D). Use the following procedure to install the spindle assembly. Reverse the order to remove the spindle. Fig. 14

Warning: When changing tools, making adjustments, or doing clean-up and maintenance, always turn the machine off and unplug the machine from its power source.

1. Raise the arbor (H) all the way using the handwheel located on the front of the cabinet. Loosen two lock knobs (E) and slide fence (J) to rear. Remove cutter guard (K). Loosen two lock knobs (F) and slide guard cover (G) back.

Locking the Arbor

2. Locate the spindle lock (L) which is accessible through the door on the right side of the cabinet. Pull out and rotate 90° right or left, resetting the knob into the indent.

Turn the arbor (H) by hand until it locks, then verify that it will not rotate.

Installing the Spindle Assembly

3. Thread the spindle nut (D) onto the threaded end of the spindle (C) in the direction indicated by arrows (A1, A2). Tighten securely by hand.
4. Thread the spindle assembly (B) and nut (D) onto the arbor (H) and hand-tighten only.
5. Insert the draw bar (O) through the opening in the shaft (N) just below the drive belt (M). Turn clockwise, fastening and securing it to the spindle. Tighten the draw bar (O) with spindle wrench (Inset A).
6. Tighten the nut (D) with the spindle wrench provided (Inset A).

Shaper Cutter installation is described on the following page. **Note that at this time the arbor is still locked.**

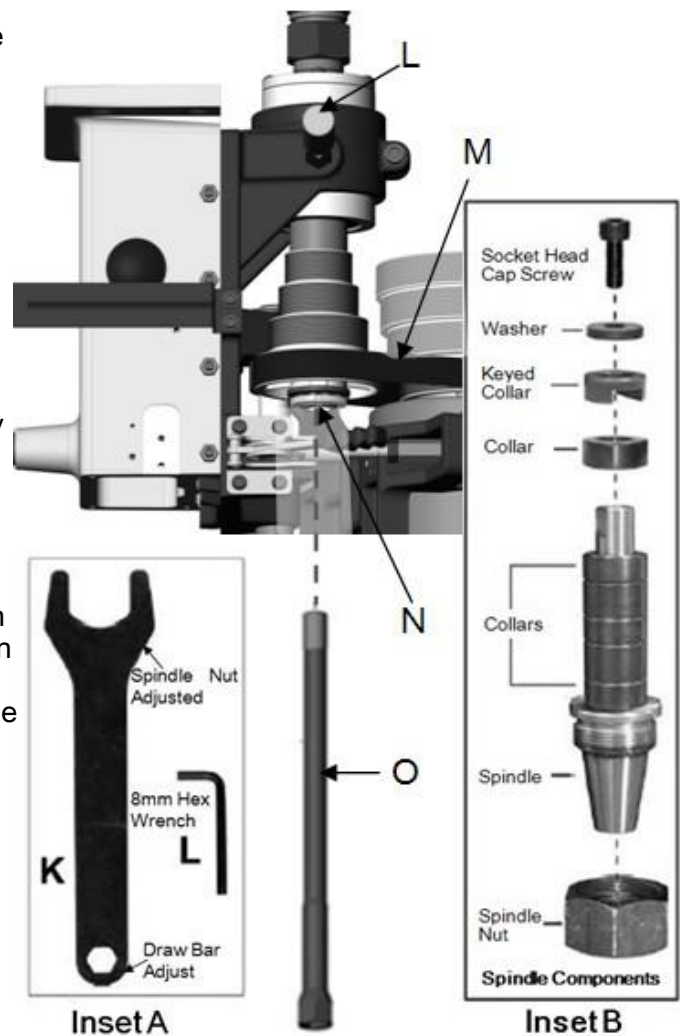
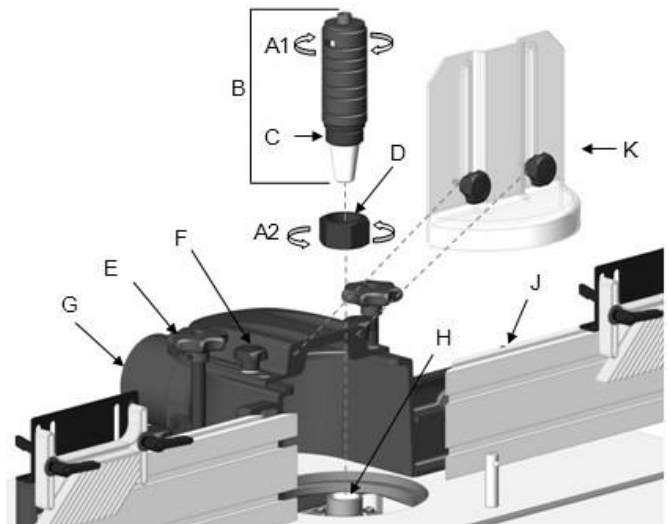

Fig. 14

Spindle Assembly Removal

The arbor must be locked as described in Spindle Attachment Installation, step 2 (Fig. 14)

1. Remove the draw bar (O).
2. Loosen the spindle nut (D) then, using the spindle wrench (Inset A) continue to turn until the spindle breaks free of the arbor.

Shaper Cutter Installation

Note: Spindle installation is described in the previous section.

Warning: When changing tools, making adjustments, or doing clean-up and maintenance, always turn the machine off and unplug the machine from its power source.

Locking the Spindle

1. Locate the spindle lock (L, Fig.14) accessible through the door on the right side of the cabinet. Pull out and rotate 90° right or left, resetting the knob into the indent.

Attempt to turn the spindle assembly (B, Fig. 14) by hand to verify that it is locked and will not rotate.

Installing the Shaper Cutter

2. Using an 8mm hex wrench (provided), remove the socket head cap screw (F) Fig. 15.
3. Remove the washer (E), keyed collar (C) and all or as many collars (B) as necessary.
4. Place the shaper cutter (A) (not included) onto the spindle, oriented in the proper direction.
5. Place the collars (B) and keyed collar (C) onto the spindle.

Note: Collars come in several widths and the stacked selection (B) must be such that the top of the keyed collar (C) sits slightly above the top of the spindle (D). This will ensure sufficient pressure to properly secure the shaper cutter (A) when installation is complete.

6. Replace the washer (E) and socket head cap screw (F). Tighten screw with the 8mm hex wrench provided.

Unlocking the Spindle

7. Pull out the spindle lock (L, Fig. 16) accessible through the door on the right side of the cabinet. Rotate 90° right or left, resetting the knob into the indent.

Using gloves to prevent injury from the shaper cutter, turn the spindle assembly by hand to verify that it turns freely.

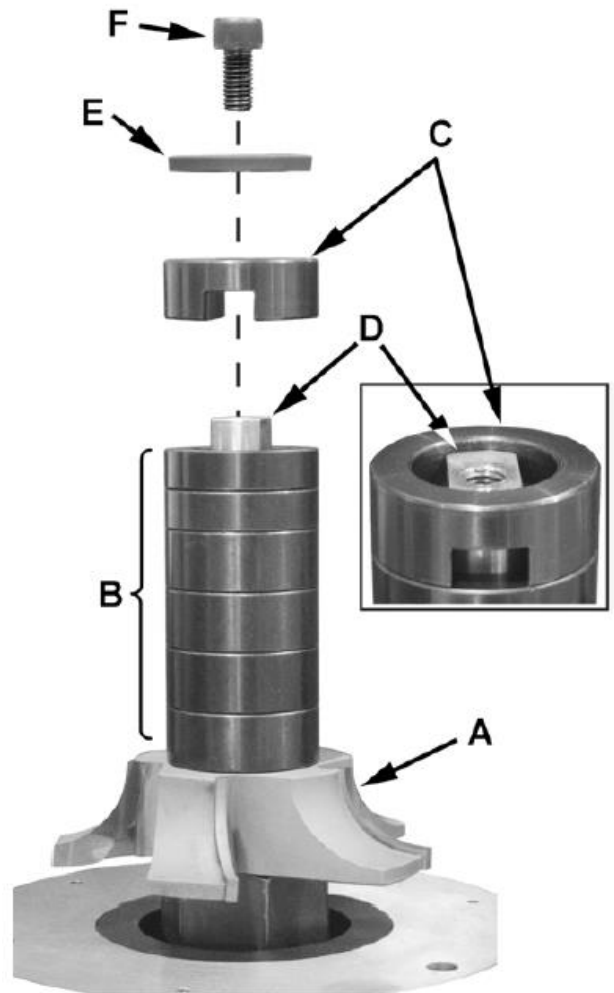

Fig. 15

Changing Spindle Speed

This Shaper is equipped with pulleys that allow you to change the spindle speed. The belt placed on the upper pulleys as shown in position B (Fig. 18) provides a 10,000 RPM spindle speed. Spindle speed for all belt positions are listed in Table 2 below.

*Belt	Spindle Speed
B	10,000 RPM
C	8,000 RPM
D	6,000 RPM
E	4,000 RPM

* Refer to Figure 14
Table 2

To change speed:

1. Disconnect the machine from the power source.
2. Open the door of the cabinet.
3. Remove the belt tension by moving the belt tension handle (A) to the unlock position. This allows the motor (G) to swivel on its mounting hinge (Fig. 16).
4. Move the drive belt (shown in the B position) to the C, D, or E positions for the spindle speed desired as determined in Table 2.
5. Lock the belt tension handle (A) which secures the motor (G) and places tension on the drive belt (K).

Belt Replacement

Replace the drive belt (K) as follows (Fig. 18):

1. Disconnect the machine from the power source.
2. Open the door of the cabinet.
3. Remove the belt tension by moving the belt tension handle (A) to the unlock position. This allows the motor (G) to swivel on its mounting hinge.
4. Work the drive belt down all the way past the pulleys.
5. Continue sliding the belt down on the left side until it is free of the bottom pulley (E), then remove the belt over the top of the motor pulley (B).
6. Install the new belt by following these steps in reverse

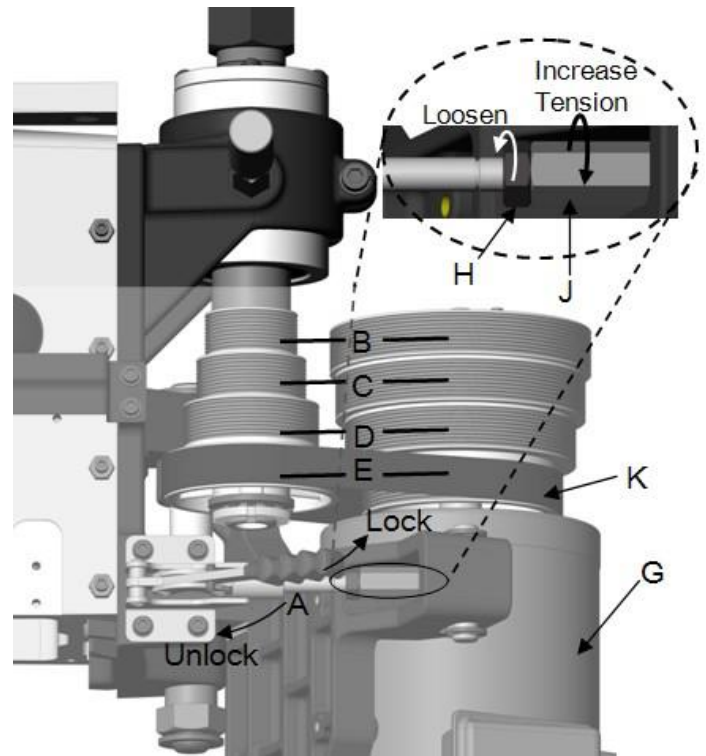

Drive Belt Tension

The drive belt should have sufficient tension to prevent slippage when the machine is in operation. If the tension on the belt needs adjustment (Fig. 18)

1. Disconnect the machine from the power source.
2. Open the door of the cabinet.
3. Locate the belt tension assembly (F) and loosen the lock nut (H, inset) with a 17mm wrench.
4. Adjust the hex bushing (J) with a 17mm wrench (refer to inset for adjustment direction) for proper tension on the belt (B). The tension handle (A) must be in the locked position (right) while performing this step.

Note: Two 17mm wrenches are required for the next step.

4. Maintain the position of the hex bushing (J) with one wrench while tightening the lock nut (H) with the other.

Precision Miter Gauge

Setting the miter gauge angle

The precision miter gauge has a rack and pinion adjustment for setting the angle. To operate (Fig.17):

1. Slide the miter gauge into one of the slots on the table top.
2. Loosen lock handle (A).
To adjust the body (B) of the miter gauge to the desired angle:
3. Pull the spring-loaded knob (C) out and turn until the body (B) of the miter gauge is at the desired angle as indicated on the scale.
4. Tighten the lock handle (A).

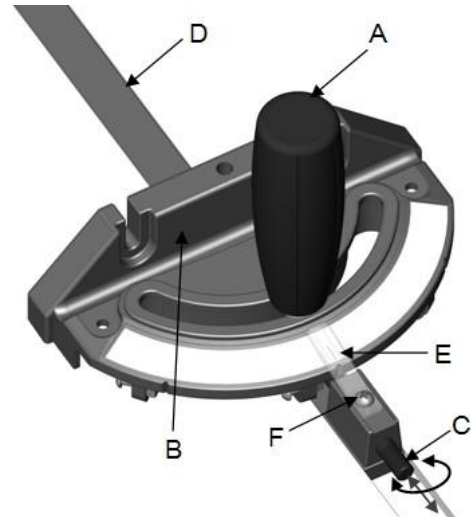

Fig. 17

Indent settings

There are indents at the 0°, 30° and 45° right and left positions. At these settings, release the knob (C) to engage the stop rod. Then tighten the lock handle (A)

Note: Do not rely solely on the indents for an accurate setting. After the stop rod engages at the 0°, 30° and 45° positions, make a fine adjustment with the knob (C) by pulling out and rotating, if necessary, setting it against the scale indicator.

Calibrating the miter gauge

- 1.
2. Place the miter gauge in one of the slots (H) on the table top.
3. Set the miter gauge to 90° (0° setting on the scale) by loosening the lock handle (A), then pulling the spring-loaded knob (C) out and turning the body (B) until 0° is indicated on the scale.
4. Measure the accuracy of the gauge against the slot with a combination square.

If adjustment is necessary:

5. Adjust the *body* (B) until it is perfectly square (90°) to the miter slot (D).
6. Tighten the *lock handle* (A).
Verify that the scale indicator (E) reads 0°. If further adjustment is necessary:
7. Loosen the *screw* (F) and adjust the indicator (E) until it reads 0°
8. Tighten the *screw* (F).

Switch

The sharper is equipped with magnetic switch & Reverse switch that Mag. Switch will accept a safety padlock (not included).

See Fig. 18. To safeguard your machine from unauthorized operation and accidental starting by young children, the use of a padlock is required.

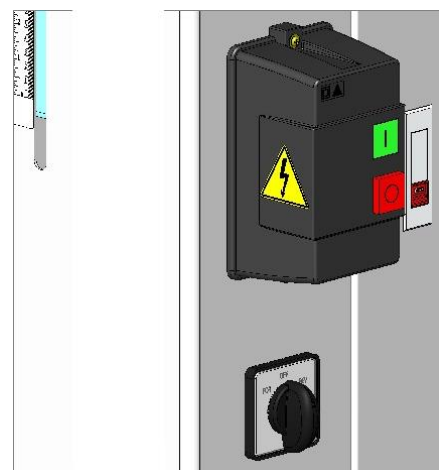
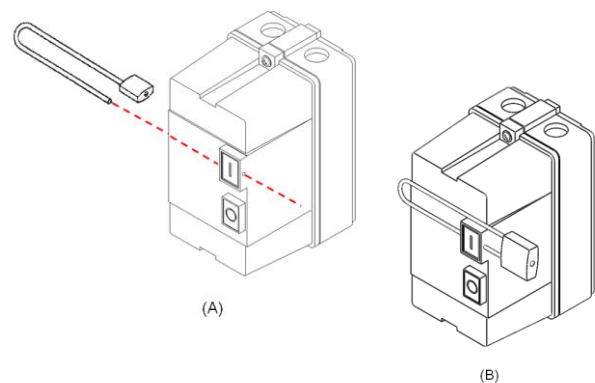

Fig. 18

Operations

Overview

Before applying power to the machine, Check the motor and switch wiring diagrams for proper voltage connections. Check that all mounting screws and bolts are tight.

Turn on the motor momentarily to check for proper rotation. The spindle should rotate counterclockwise when looking down on the spindle. Correct as required.

Run the machine for a short period of time to ensure that the moving parts are working properly with no excessive vibration. If a problem develops, correct it before turning the shaper over for general use.

Safety Devices

Safety devices such as guards, fixtures, templates hold-downs, push sticks (Fig. 19), feather boards and power feeders should be used whenever possible. Fig. 19 shows a push stick which can be easily made from scrap wood.

Note: For the sake of clarity, the shaper guard has been omitted from most illustrations. All shaper operations must be done with the proper guard in place and any other device which insures the safety of the operator.

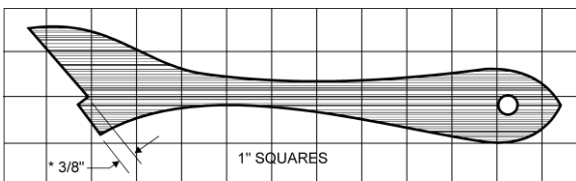

* This measurement may vary depending upon thickness of workpiece.

Fig. 19

Grain Direction Considerations

Plan to shape the workpiece in the same direction as the grain when possible. Some open grain woods (such as redwood, fir and oak) will leave a rough, or slightly splintered edge when cut against the grain.

CAUTION : Deep cuts require excessive horsepower and pushing force to control the cut.

Deep cuts can also cause the wood to splinter or split and may lead to lost control or personal injury. Preband shaper the stock whenever possible to 1/16 inch of finished size. When an edge finish is unsatisfactory, take two or more cuts with the final cut no more than 1/16 inch deep.

In the case of shaping across the grain, the trailing board edge will often splinter. To correct this, the best solution is to make the board 1/4 inch oversize in width, shape the board, and simply trim off the excess.

Cutter Rotation

Counterclockwise Setup – With the cutter installed as shown in Fig. 20, feed the workpiece from right to left.

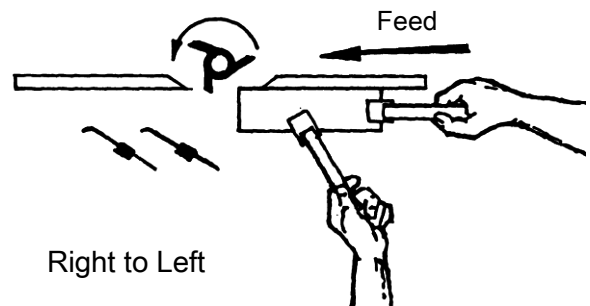

Fig. 20

Clockwise Setup – With the cutter installed as shown in Fig. 21, feed the workpiece from left to right.

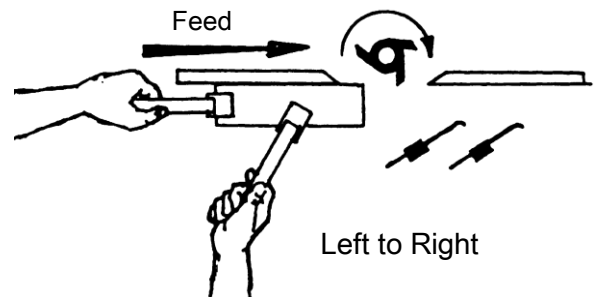

Fig. 21

Using the Fence

Using the fence is the safest and most satisfactory method of shaping, and should always be used when the work permits. Almost all straight work can be used with the fence.

For average work, where a portion of the original edge of the work is not to be touched by the cutter, both the front and rear fences are set in a straight line as shown in Fig. 22.

When the shaping operation removes the entire edge of the work, e.g. in jointing or making a full bead, the shaped edge will not be supported by the outfeed fence when both fences are in line, Fig. 23. In this case, the stock should be advanced to the position shown in Fig. 21 and stopped. Turn off the machine and move the outfeed fence forward to contact the workpiece, Fig. 24. Remove the workpiece, start the motor, and then continue the operation.

Warning : Always remove workpiece before starting the machine! This will prevent kickback and potential serious injury.

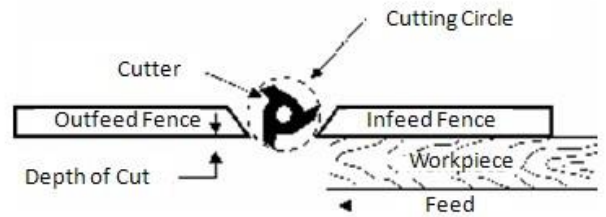

ig. 22

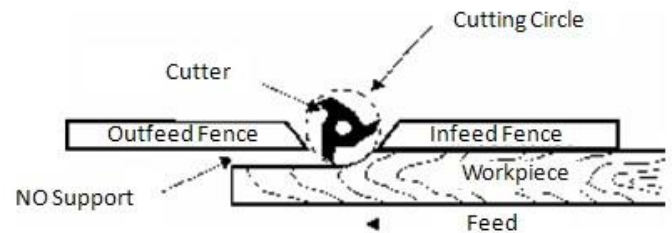

Fig. 23

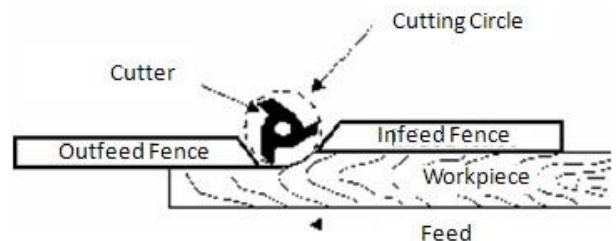

Fig. 24

"Z" Dimension

Before making a template (or using the edge of the workpiece) for shaper cutting, the "Z" dimension must be established in order to determine the shape and size of the finished stock. The "Z" dimension is the difference between the innermost part of the cutter edge and the outside diameter of the ball bearing follower (collar). See Fig.25.

Note: The "Z" dimension can be either positive or negative.

The "Z" dimension is positive if the cutter is larger than the collar bearing.

The "Z" dimension is negative if the cutter is smaller than the collar bearing.

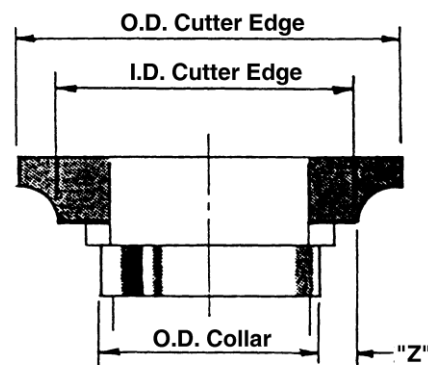

Fig. 25

Depth of Cut

The depth of cut is the distance from the outside circumference edge of the collar (which the work rides against) to the outside edge of the cutter. The depth of cut is determined by the position of the fence relative to the cutterhead and/or by the use of shaper collars (see Fig. 26).

Straight Edge Shaping

Straight edge shaping is always performed with the workpiece against the fence. Use only push sticks and hold downs to keep the workpiece on position.

WARNING: Do not use a miter gauge to feed material along the fence face. The workpiece can bind and cause kickback. Failure to comply may cause serious injury!

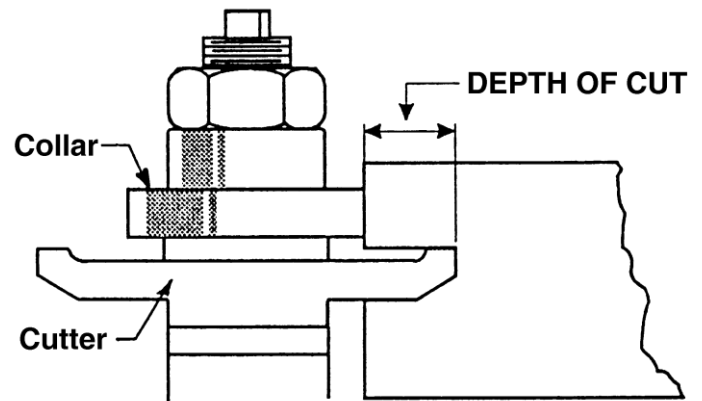

Fig. 26

To set up:

1. Disconnect or unplug the machine from its power source.
2. Check to see that the fence faces are parallel, properly in line or offset if necessary, and securely tightened.
3. Rotate the cutters and inspect for clearance.
4. Lock the spindle.
5. Install all necessary guards.
6. Reconnect power to the machine.
7. Take a trial cut on a piece of scrap the same thickness as workpiece.

Note: Only a short cut is necessary to determine if the profile, depth, and height of cut is correct.

Edge Shaping

When edge shaping, never attempt to hand guide any stock less than 12 inches long, or narrower than 3 inches without the use of a special guide as shown in Fig. 27.

CAUTION: When edge shaping, the workpiece must be at least 12 inches long unless a special guide is used.

1. Use the hold-ins and hold-downs as shown in Fig. 28 to firmly hold the workpiece down and against the fence. If workpiece is too wide for the hold-ins to be used, clamp a scrap board to the table to substitute for the hold-ins.
2. Check the rotation of the cutter. Be sure to feed workpiece against rotation of the cutter.
3. Feed the workpiece slowly and steadily with firm, even pressure to make a smooth cut.

Important: The rate of feed depends on depth of cut and experience of operator.

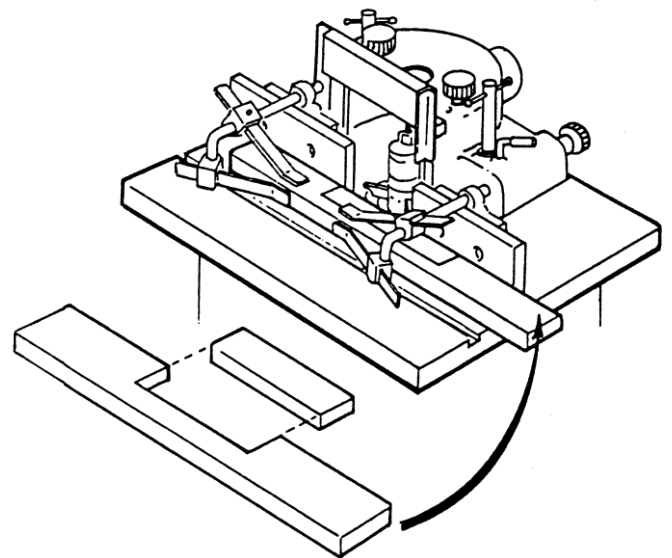
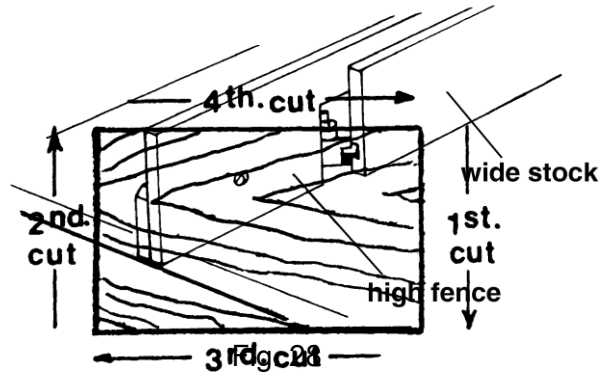

Fig. 27

End Shaping

When end shaping narrow stock, it is important that at least one half of the workpiece end be in contact with either the infeed or outfeed fence. Use a guide similar to the one shown in Fig.28 which tightly clamps the scrap piece to the workpiece and provides the necessary width.

WARNING: End shaping a narrow workpiece without a special guide could result in the workpiece rocking into the cutterhead, causing personal injury.



Shaping All Sides

Because cross grain shaping is more likely to create chipping out and splinters on some woods, it is good practice to first shape the cross-grain sides. Any chipping that does occur is taken care of by the with-grain cuts, as shown in Fig.29.

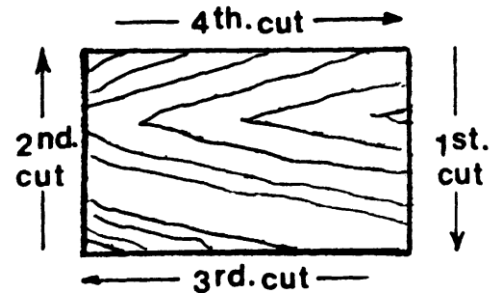

Fig. 29

On-Edge Shaping

If the shaper fence does not firmly support wide stock, use the T-slots in the fence to attach a special rigid high fence as shown in Fig.30.

Note: Be sure the screw holes are countersunk in the special fence to avoid interference with the workpiece.

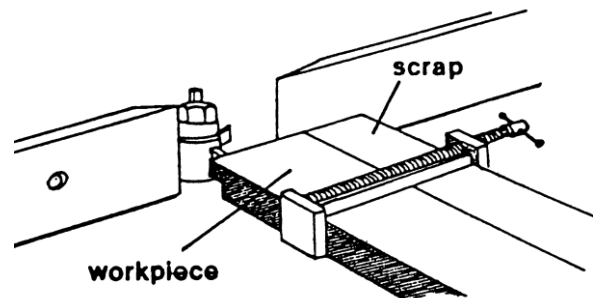
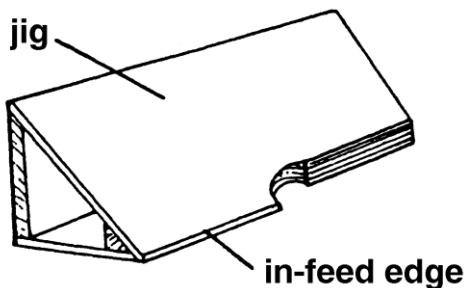

Fig. 30

Straight Line Bevel Shaping

To shape a beveled straight edge, use a bevel-edge shaping jig in combination with the regular fence as below.



To perform a bevel-edge cut, the in-feed edge of the jig is placed against the infeed fence and clamped to the table as shown in Fig. 31. The outfeed fence is moved forward as necessary to compensate for the cut.

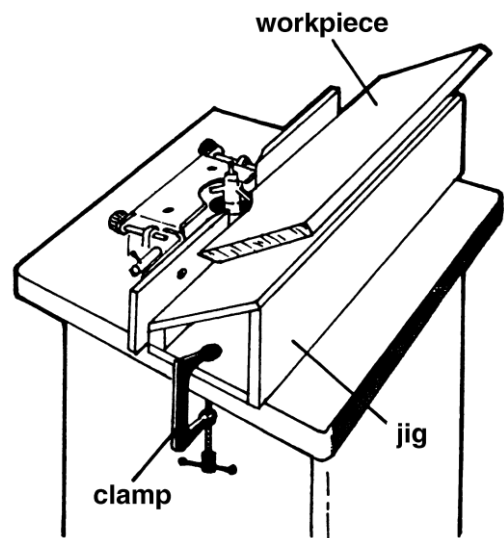

Fig. 31

Contour Edge Shaping With Collar Bearing

To shape contoured edges, the operator must first remove the fence assembly.

In order to control the workpiece and limit the depth-of-cut, the operator must use an anti-friction collar with the cutter(s) as shown in Fig. 32.

The collar may be positioned above or below the cutter(s), and its function is to ride against the workpiece or template. At the same time, the collar will establish the depth-of-cut as shown in Fig. 33. Whenever possible, always use the ring guard or safety collar

Note : Since the collar requires at least 1/8" of surface edge to ride against, the entire edge cannot be shaped as shown in Figure 34. The added use of a pattern, however, permits the shaping of the entire contour edge.

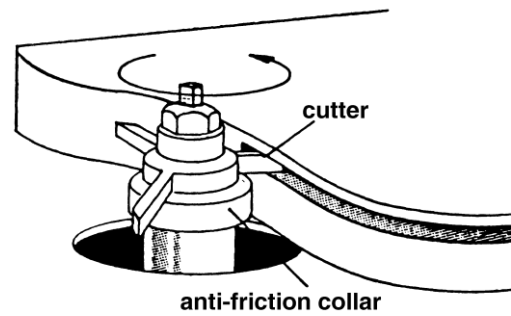

Fig. 32

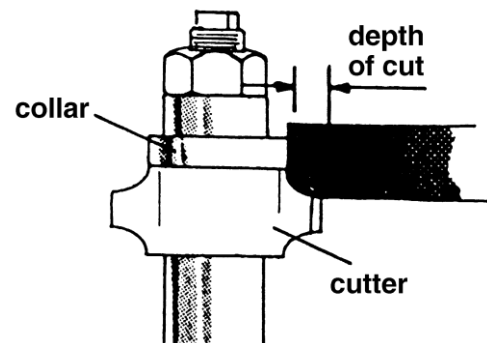

Fig. 33

If the workpiece is to be shaped all around the perimeter, hold it firmly and push the work straight into the cutter until the depth of cut is established by the collar as shown in Fig. 35. Continue to feed the work so that the point of contact on the edge is always 90 degrees to the collar (or directly in line with the cutter edge) and held firmly against it.

When the workpiece is not contoured all around, start the cut as shown in Fig. 40. With this operation, the workpiece is positioned against the starter pin and the end swung into place to start the cut. When the cut has begun and the workpiece firmly against the collar, swing the stock away from the pin and proceed with cut.

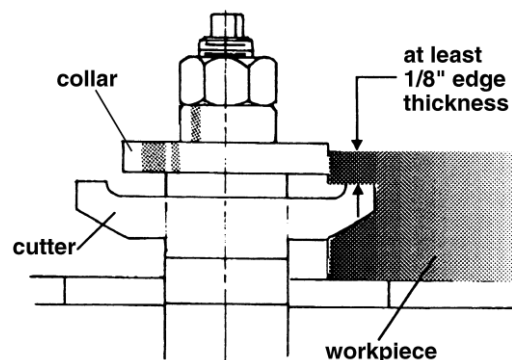

Fig. 34

WARNING: Freehand shaping is extremely dangerous. The operator must be aware at all times of the proximity of his hands to the cutter. Hands must never come closer than 12 inches to the cutter without the proper guard or similar safety device over the cutterhead.

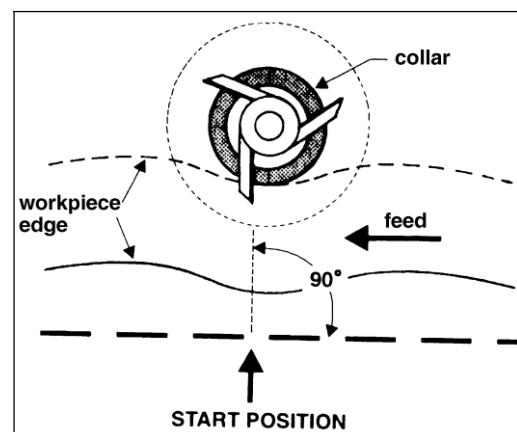

Fig. 35

Shaping With Collars

When shaping with collars and starting pin, always adhere to the following rules for good work and safe operation:

The collar must have sufficient bearing surface, as shown in Fig. 36. Also, the stock must be fairly heavy in proportion to the cut being made. Under no circumstances should a short, light workpiece be shaped against the collars, as in Fig. 37.

Note: The edge of the work to be shaped must be smooth. Any irregularity on the surface which rides against the collar will be duplicated on the molded surface.

Collars must be smooth and free from pitch and other substances.

Position of Collars

Collars may be used above, below or between cutterheads.

1. When the collar is used below the cutter, as shown in Fig. 38, the progress of the cut can be seen throughout the operation. However, any accidental lifting of the work will gouge the wood and ruin the workpiece.
2. When the collar is used above the cutter Fig. 38, the cut cannot be seen. But this method offers an advantage in that the cut is not affected by slight variations in the thickness of the stock. Also, accidental lifting of the workpiece will not gouge the workpiece; simply repeat the operation to correct the mistake.
3. Using the collar between the two cutters has the advantages and disadvantages of the first two procedures, and is frequently used where both edges of the work are to be molded, Fig. 39.

Note: It is advisable to place the cutter as low as possible on the spindle to reduce spindle deflection and ensure the best possible finish. Also make sure that the contacting surfaces of the cutter are smooth, clean and without dents.

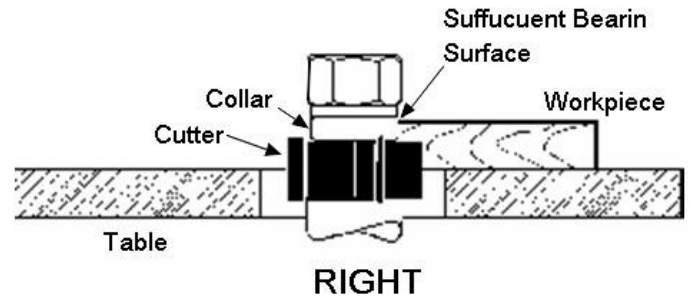

Fig. 36

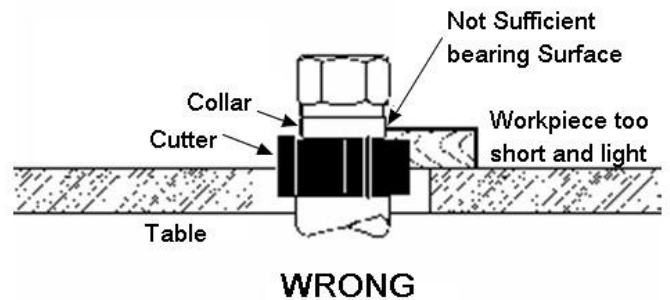

Fig. 37

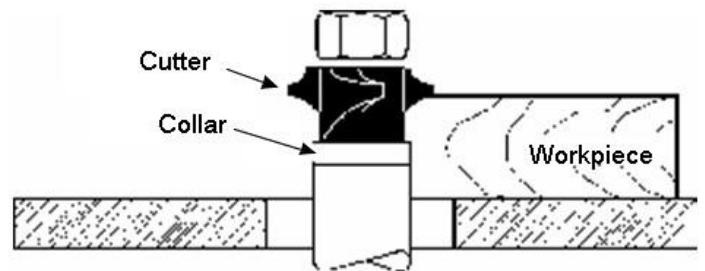

Fig. 38

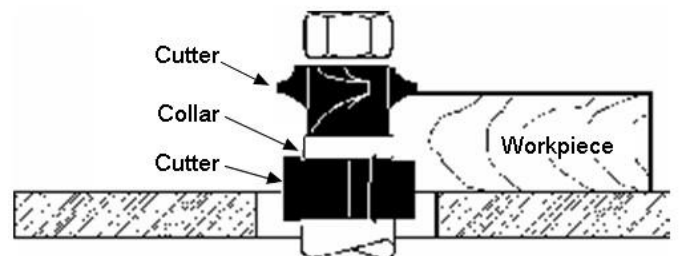

Fig. 39

Starting Pin

WARNING: Use of the starting pin should only be attempted by advanced users. If you have never used this method, it is recommended you get training from a qualified person. Failure to comply may result in serious injury.

The starting pin is used to support the work when starting the cut.

1. The work should be placed in the position A, (Fig. 40), using the starting pin as a support
2. Swing the work into the cutter as shown in the position B. The work is now supported by the starting pin and the collar.
2. After the cut has been started, the work is swung free of the starting pin and only rides against the collar (Fig. 41). Always feed against the cutterhead rotation.

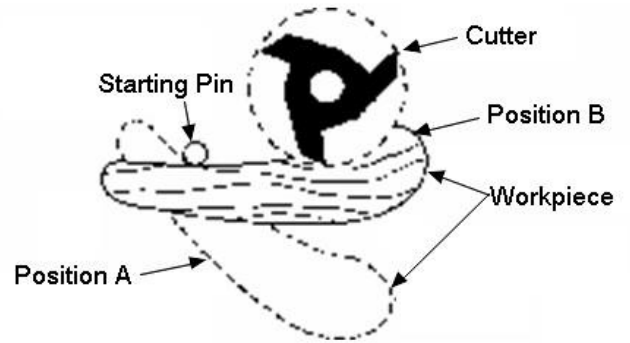

Fig. 40

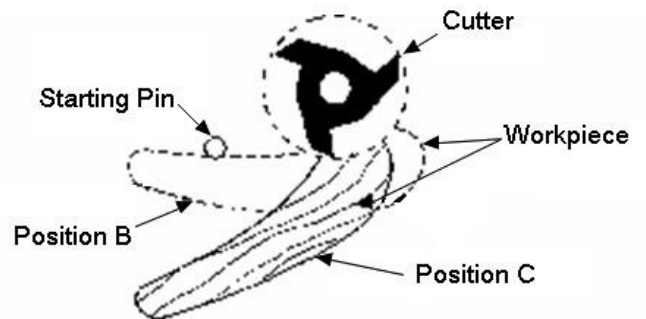

Fig. 41

Arcs and Circles

Large circular and arc-shaped stock can be shaped as described in Contour Edge Shaping on page 17. However, smaller sized stock requires the use of special shaping jigs similar to those shown in Fig. 42.

With the entire fence assembly removed, carefully position the jig for desired depth-of-cut and securely clamp to the table.

It is important with the arc and circle shapes that the workpiece, prior to being shaped, must be roughly cut to the desired size and curve of the finished piece. Make sure that the jig curve matches exactly the workpiece curve. At all times keep the workpiece firmly in contact with the jig while the cutter is cutting the stock.

CAUTION : Never perform this type operation without a ring guard, safety collar or similar safety device over the cutterhead.

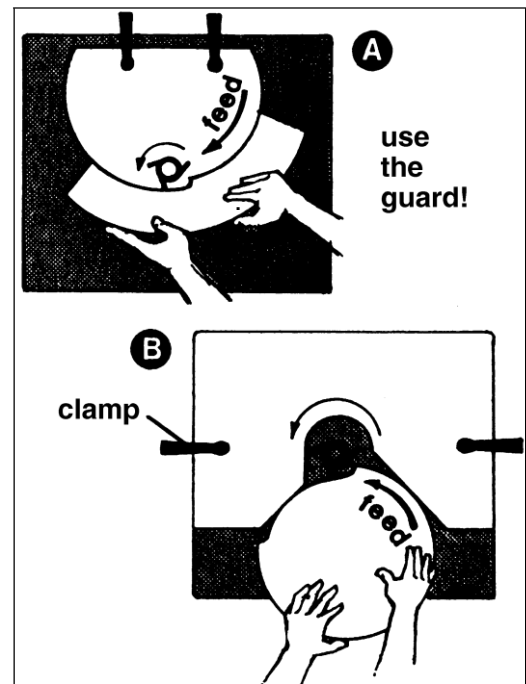

Fig. 42

Enclosed Edge Shaping

An enclosed workpiece edge is shaped in the same manner as an outside contoured edge except that a starting pin is not required as shown in Fig. 43.

Note : If the whole edge is to be shaped, the operator must use a pattern.

Position the workpiece on the table before starting the motor. The operator must do the entire shaping cut by pushing (feeding) the workpiece into the cutter(s).

WARNING: Enclosed edge shaping is extremely dangerous. The operator must be aware at all times of the direction of feed. Never perform this type operation without a ring guard, safety collar or similar safety device over the cutterhead.

With a firm grip, ease the edge into the cutter(s) until stopped by the collar as shown in Fig. 43.

Continue to push straight in while feeding and turning the workpiece at the same time until the cut is finished. Turn off the motor and do not remove workpiece until the cutters have completely stopped.

CAUTION : Never perform enclosed edge shaping if there is less than two inches of workpiece material all around the opening. Never perform enclosed edge shaping if the workpiece opening is smaller, in any direction, than twice the diameter of the cutter(s).

Templates

The template must be thick enough to provide a solid bearing edge against a collar. When constructing a template similar to the one shown in Fig. 44, keep in mind that it serves only as a guide for the cutter.

If the workpiece requires all-around shaping, the template can be constructed from several sections pieced together as shown in Fig. 45.

Securing the Template

There are various methods used to secure the template to the workpiece. The experienced operator will choose the most appropriate according to the shape, size, and type construction of the template. For example, if the workpiece is large enough to extend beyond the front of the table and still leave room for the desired cut, it can be securely held to the template with "C" clamps as shown in Fig. 46. In many situations the workpiece is positioned against the template using dowels as anchor points and handles (wood blocks) to assist the operator in guiding the work-piece through the cut as shown in Fig. 47.

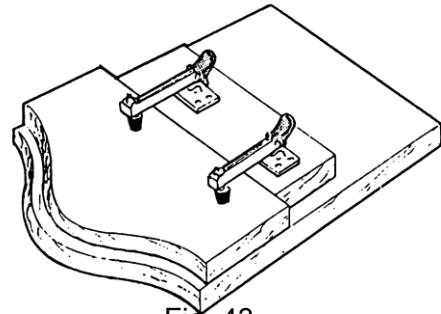

Fig. 43

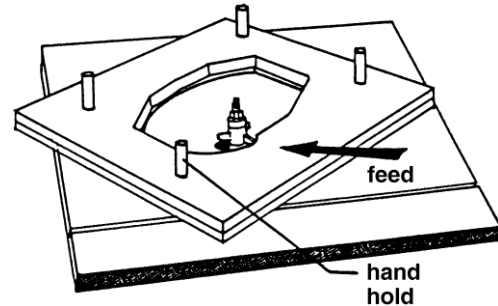

Fig. 44

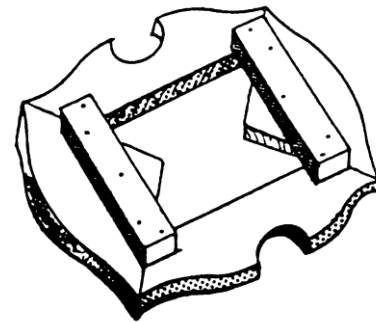

Fig. 45

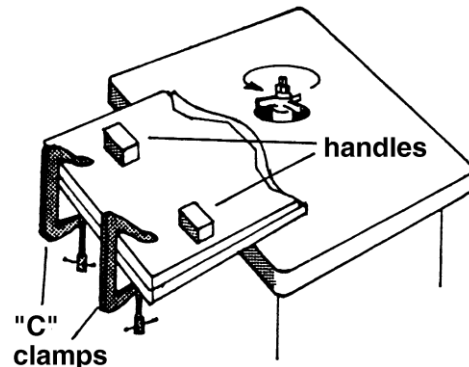

Fig. 46

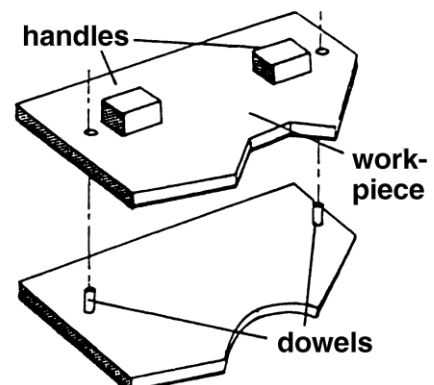

Fig. 47

Special Cuts

The illustrations in this section show the profile, or section, views made by the cutter(s). The most efficient cutters are carbide tipped to ensure clean and long-term cutting. Small cutters may be solid carbide, and some use inserts. Since there are such a wide variety of choices, the operator is limited only by his experience and imagination. Some profiles require router bits and use of optional collets.

Stacked Cutters

A variety of interesting and time saving cuts can be made in a single setup by stacking the cutters. When the operator stacks the cutters, extra care should be taken to see that all parts are clean, free of nicks and flaws, and perfectly balanced in the stacked position.

Sash and Door Shaping

Shaping a door requires two operations.

Fig. 48 shows the sash cut for the first operation.

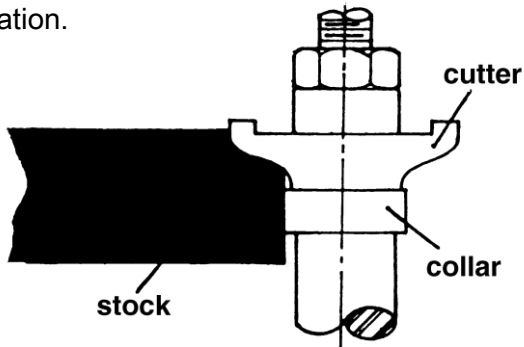

Fig. 48

Fig. 49 shows the stock flipped over and the sash cutter used with a 1/4 inch groove cutter to complete the cut.

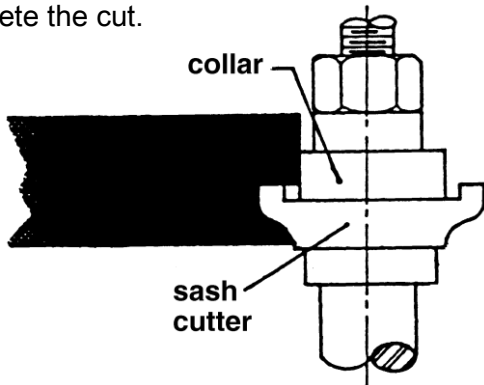

Fig. 49

Fig. 50 shows the first shaping cut with the sash cutter for the matching door stile sash.

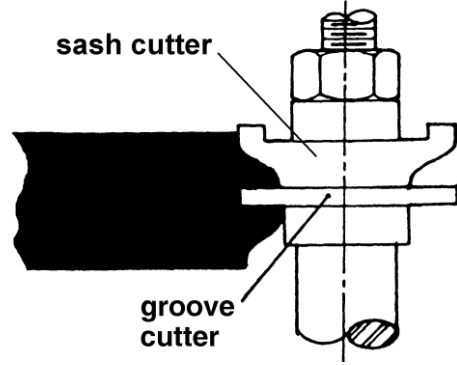

Fig. 50

Fig. 51 shows the same cut with the stock flipped over.

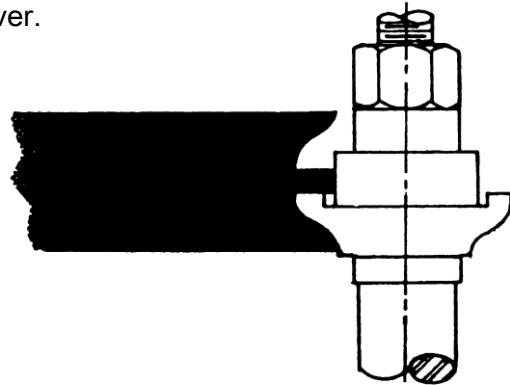

Fig. 51

Fig. 52 shows the first shaping cut for a window sash stile utilizing a sash cutter, collar, and a 1/2 inch groove cutter.

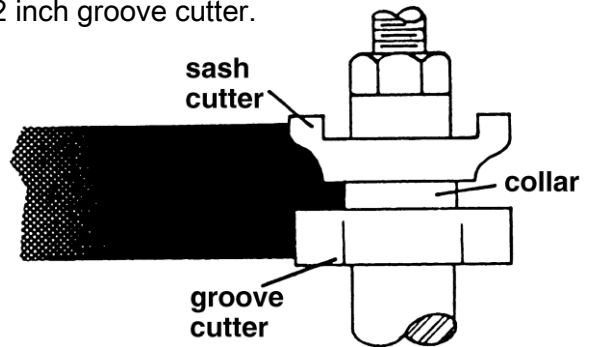

Fig. 52

Fig. 53 shows BOTH cuts required for a window sash rail end. The first operation at top is a rabbet cut made with a groove cutter. The second operation is performed with a sash spindle and buttonhead screw.

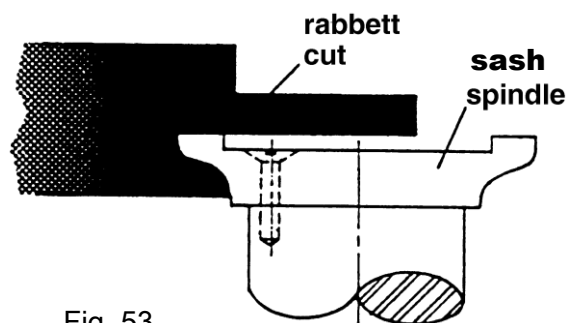

Fig. 53

Butt Joints

All butt-type joints require both workpieces to be perfectly square and straight-edged.

Glue Butt Joint

To perform a glue butt joint, both fences are kept inline and adjusted for a depth of cut (Fig. 54).

The cuts on both workpieces are part-edge cuts which do not reduce the stock width during the cutting procedure. When shaping the two workpieces, one is fed top-side up; the other is fed bottom-side up.

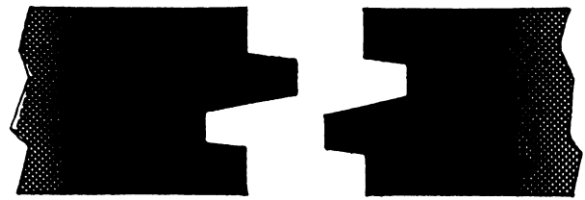

Fig. 54

Tongued Joint

Similar to the glue joint, both fences are kept in-line for the tongued joint and adjusted for a 1/4 inch depth of-cut with no reduction in stock width. With this joint however, both workpieces are fed with the same side up as shown in Fig. 55.



Fig. 55

Drop Leaf Joint

When shaping a drop-leaf joint as shown in Fig. 56, the leaf workpiece is shaped with a Drop-Leaf Bead cutter; the table workpiece is shaped with a Drop-Leaf Cove cutter.



Fig. 56

With this type joint, the whole edge of both workpieces is shaped, same-side up, and allowance made for a 1/16 inch reduction in width. Adjust the in-feed fence to reduce the workpiece width by 1/16 inch, and adjust the out-feed fence to compensate for stock removed.

Taper Cuts

Taper cuts can be made by offsetting the fences for the amount of taper desired, or with a layout line on the stock which can be paralleled to the infeed fence as shown in Fig. 57.

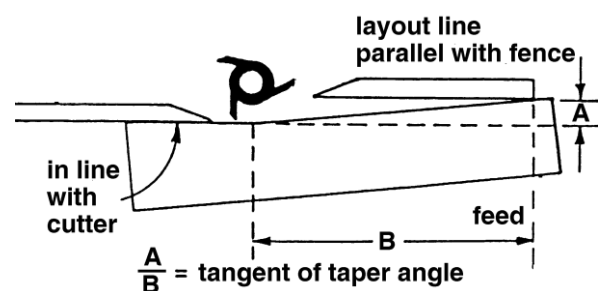

Fig. 57

Start the cut by holding the stock against the infeed fence and swinging it into contact with the outfeed fence just past the cutterhead. As the cut is started, transfer pressure to hold the workpiece against the outfeed fence, and continue feeding the workpiece through. After the first cut, the fences will have to be readjusted in order for the second cut (parallel cut) and the final depth-of-cut to remain true with the taper.

CAUTION : Do not use the standard fence for short work (12 inches or less in length on the side to be cut). Instead, use a miter gauge or special fixture to avoid losing control of the workpiece.

Tenon

The tenon fixture illustrated in Fig. 58 shows a miter gauge equipped with a hold-down for shaping the ends of narrow work-pieces.

The miter gauge can also be adapted to cut square and centered tenons at the ends of legs for tables, chairs, etc. Secure the leg to jig and position for cut as shown in Fig. 59.

Make all first cuts with the same jig setting and spindle height. When the first series of cuts have been made, reposition leg on the jig for each succeeding cut.

Note: If the leg is tapered, use a wedge to place the side facing the cutter into a 90 degree vertical position as shown in Fig. 60.

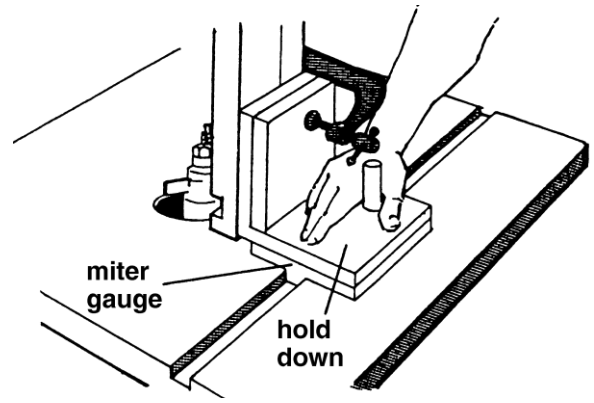

Fig. 58

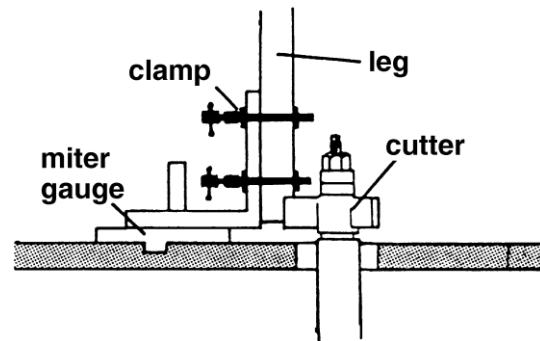

Fig. 59

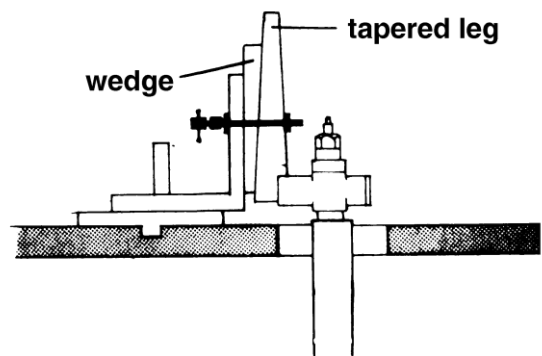

Fig. 60

Troubleshooting

Trouble	Possible Cause	Remedy
Shaper will not start.	<ol style="list-style-type: none"> 1. Cord unplugged from the power source. 2. Fuse blown or circuited breaker tripped. 3. Cord damaged. 4. Reversing switch is in the Off position. 5. Overload tripped. 6. Cabinet door is open. 	<ol style="list-style-type: none"> 1. Plug in power cord. 2. Replace use or reset circuit breaker. 3. Replace cord. 4. Turn switch to forward of reverse. 5. Reset overload by depressing
Overload kicks out frequently.	<ol style="list-style-type: none"> 1. Extension cord or wiring inadequate size. 2. Feeding stock too fast. 3. Cutter needs cleaning or replacing. See also Unsatisfactory Cuts below. 	<ol style="list-style-type: none"> 1. Replace cord or wiring with proper gauge wire. 2. Reduce feed stock rate. 3. Clean or replace cutter.
Cuts are unsatisfactory.	<ol style="list-style-type: none"> 1. Dull cutter. 2. Cutterhead rotating in Nwrong direction. 3. Feeding work in wrong direction. 4. Gum or pitch on cutter. 5. Gum or pitch on table 	<ol style="list-style-type: none"> 1. Replace cutter. 2. Check for proper rotation at startup. 3. Feed work against the cutter rotation. 4. Remove cutter and clean with solvent. 5. Clean table with solvent.
Cutter does not come up to full speed.	<ol style="list-style-type: none"> 1. Shop wire gauge is too small. 2. Extension cord or wiring inadequate size. 3. Power source is not adequate. 4. Motor not wired for correct voltage. 5. Spindle is locked with madrel lever. 	<ol style="list-style-type: none"> 1. Replace wiring with proper gauge wire. 2. Replace with adequate size cord. 3. Contact your electric utility. 4. Refer to motor name place and wiring diagram for correct wiring. 5. Unlock spindle – see label next to lover on base.
Machine vibrates.	<ol style="list-style-type: none"> 1. Stand on uneven surface. 2. Cutterhead damaged. 3. Defective V-belt. 4. V-belt incorrectly tensioned. 5. Bent pulley. 6. Motor mounted improperly. 	<ol style="list-style-type: none"> 1. Stand must rest solidly on level surface. Fasten to floor if necessary. 2. Replace cutterhead. 3. Replace V-belt. 4. Apply proper tension. 5. Replace pulley. 6. Motor must be properly mounted with snug nuts and

Trouble	Possible Cause	Remedy
Edge splits off	1. Characteristic of this type of cut.	1. Make cross grain cuts first, then finish cut with the grain. Use scrap block to support end of cut.
Raised areas	1. Variation of pressure holding work against cutter.	1. Hold work firmly against table and fence. Use hold-downs and push sticks.
Work pulled	1. Feeding in wrong direction.	1. Always feed work against the rotation of the cutterhead.
Depth of cut not uniform.	1. Fence misalignment. 2. Side pressure not uniform.	1. Align outfeed fence. 2. Use hold-downs; keep constant pressure against fence and use push sticks.
Work burns.	1. Cutting too deep on one pass.	1. On hardwoods take light cuts; attain full depth with several passes.
Cut height not uniform.	1. Variation in pressure holding work to table.	1. Keep pressure from throughout pass. Use hold-downs. Make pass slowly and steadily. Keep work under cutter whenever possible.
Cuts not smooth.	1. Wrong R.P.M. 2. Feed too fast. 3. Working against the grain. 4. Cutting too deep on one pass.	1. Use faster speed. 2. Slow feed speed. 3. Work with the grain whenever possible. 4. Take several passes on very deep cuts.
Spindle does not raise freely.	1. Shaper dust and dirt in raising mechanism.	1. Brush or blow out loose dust and dirt.

Wiring Diagrams

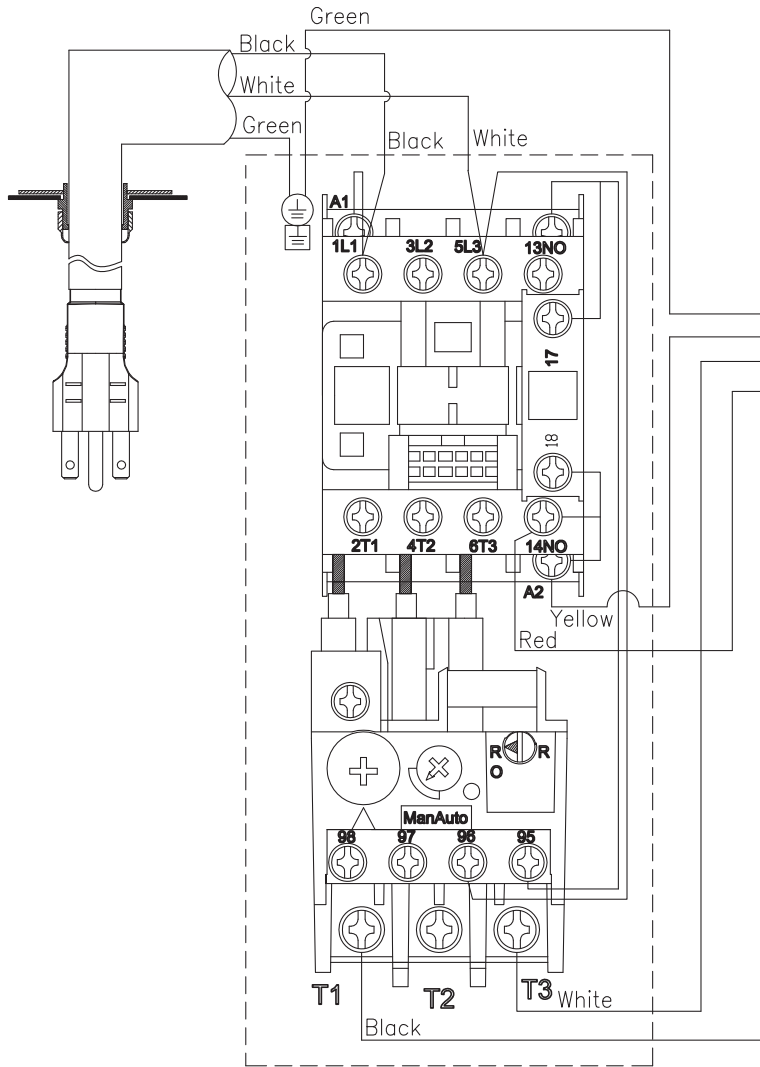

Magnetic Switch

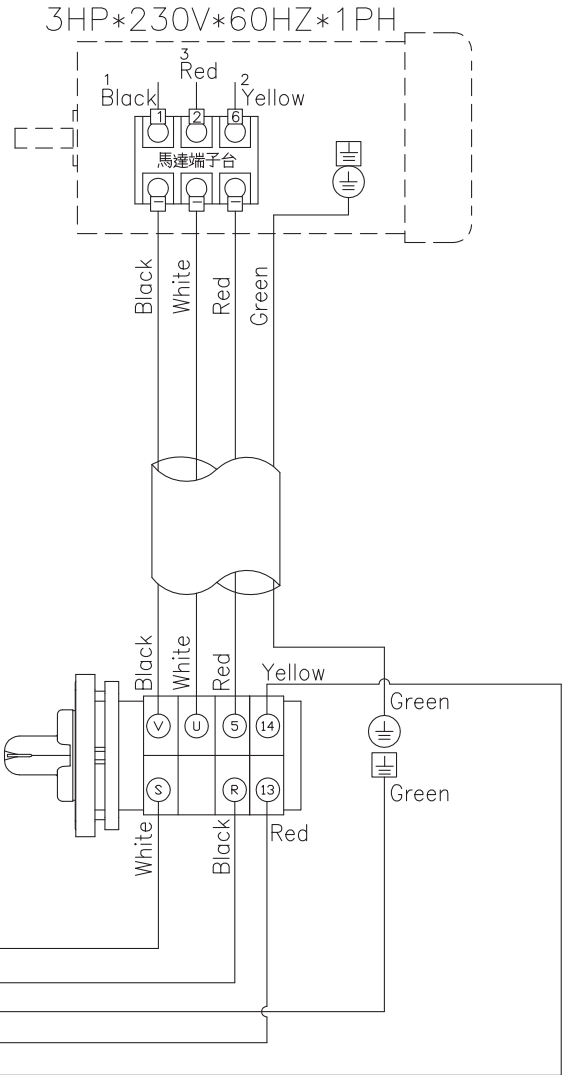

Wiring Diagrams

Wiring Diagrams

5HP*230V*60HZ*1PH

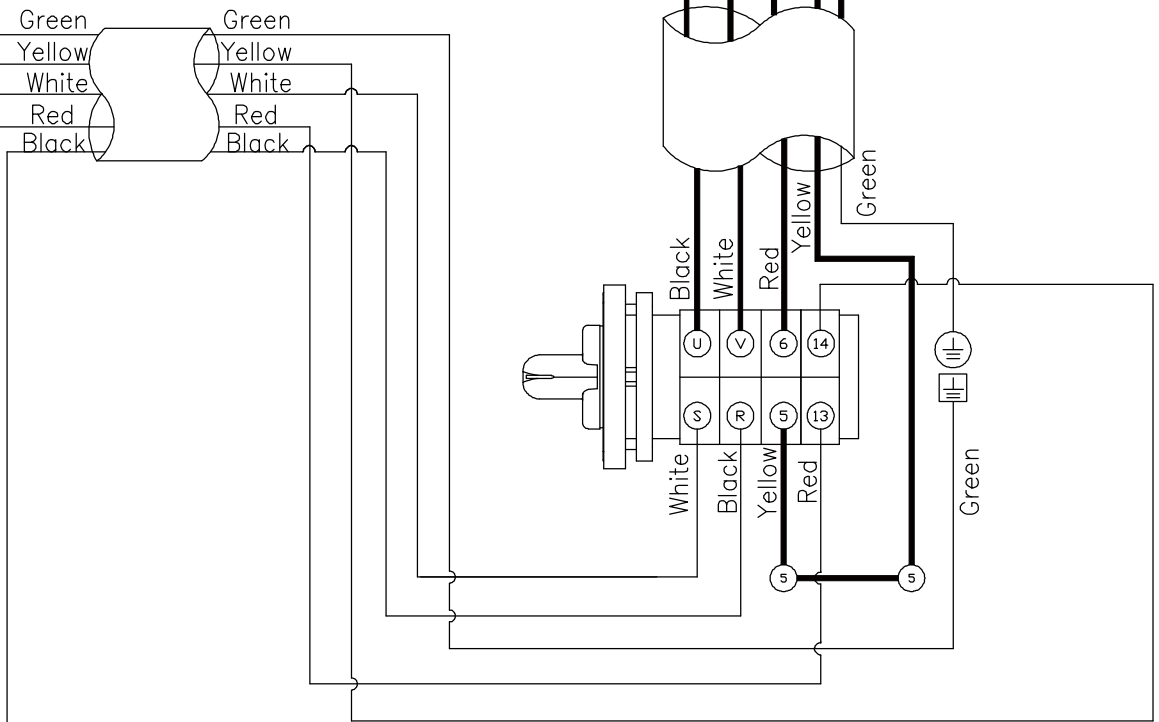
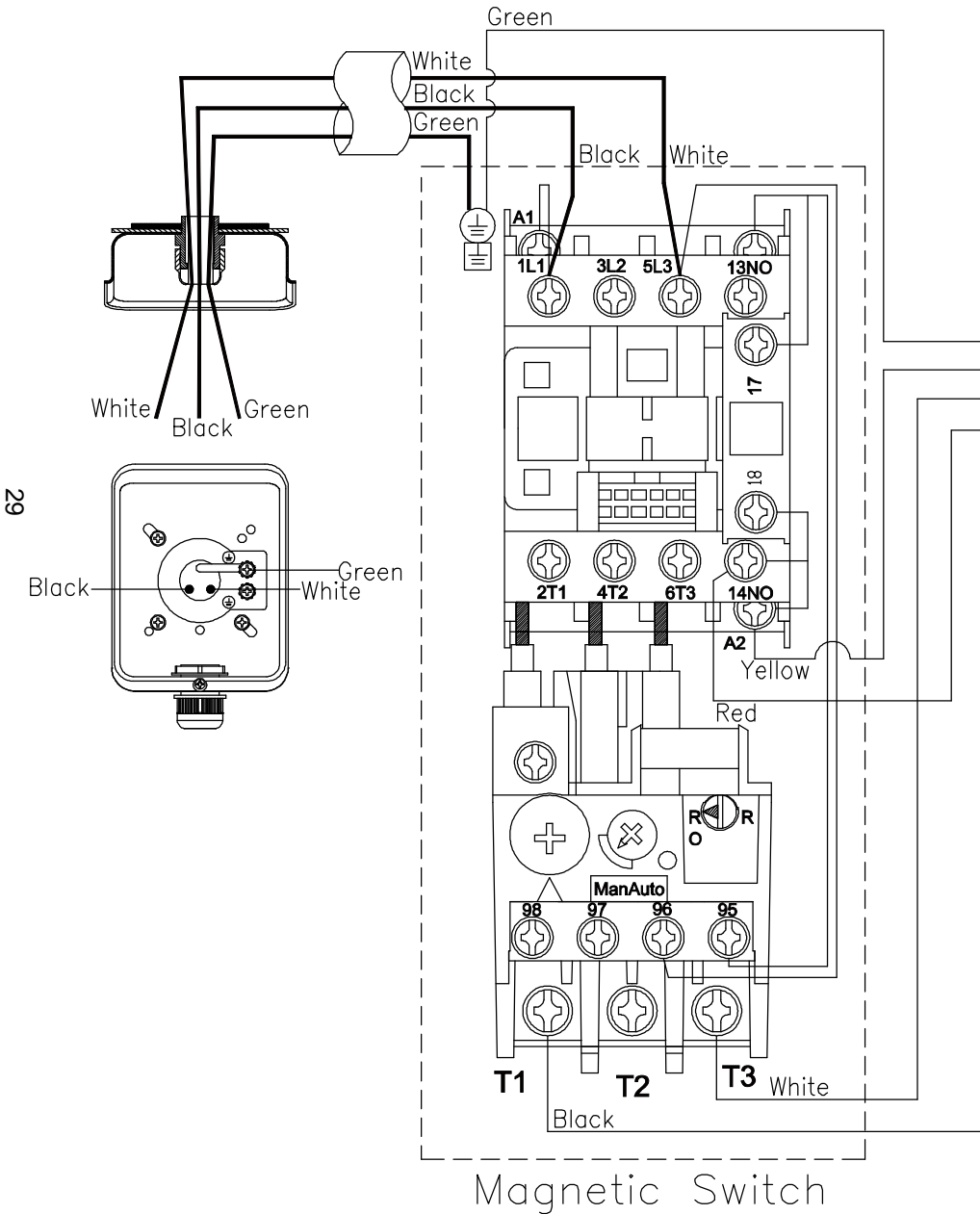

Exploded View

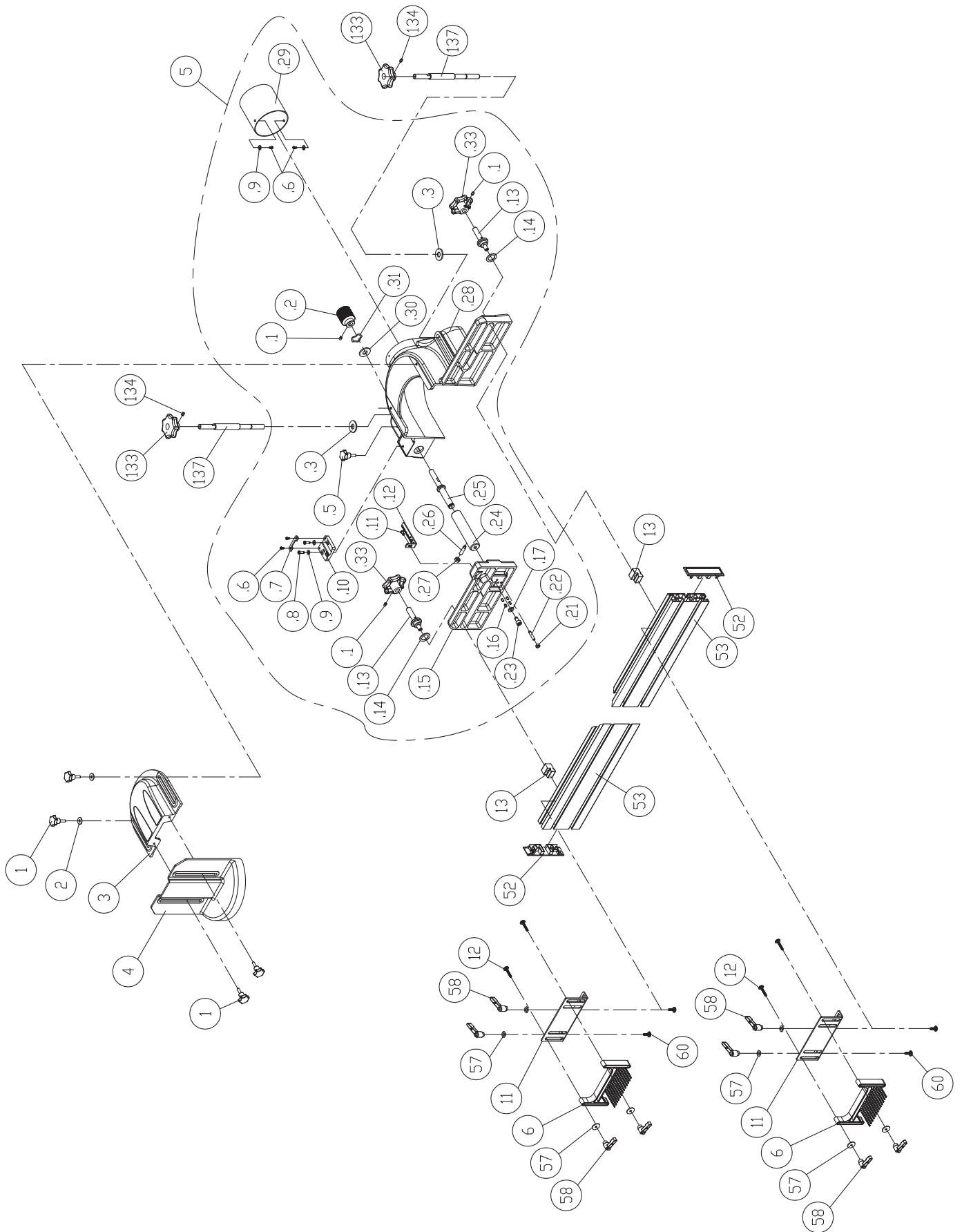

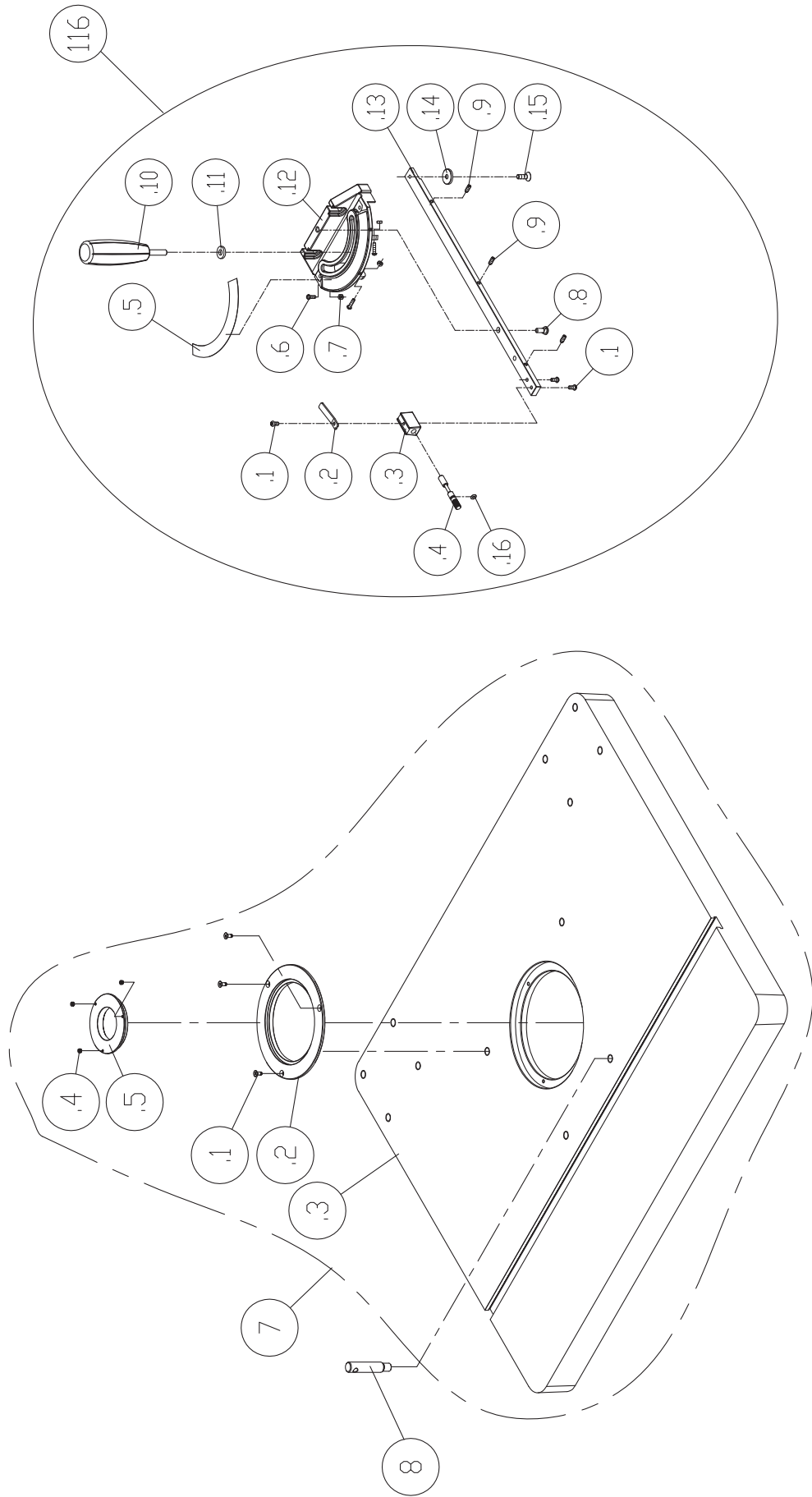

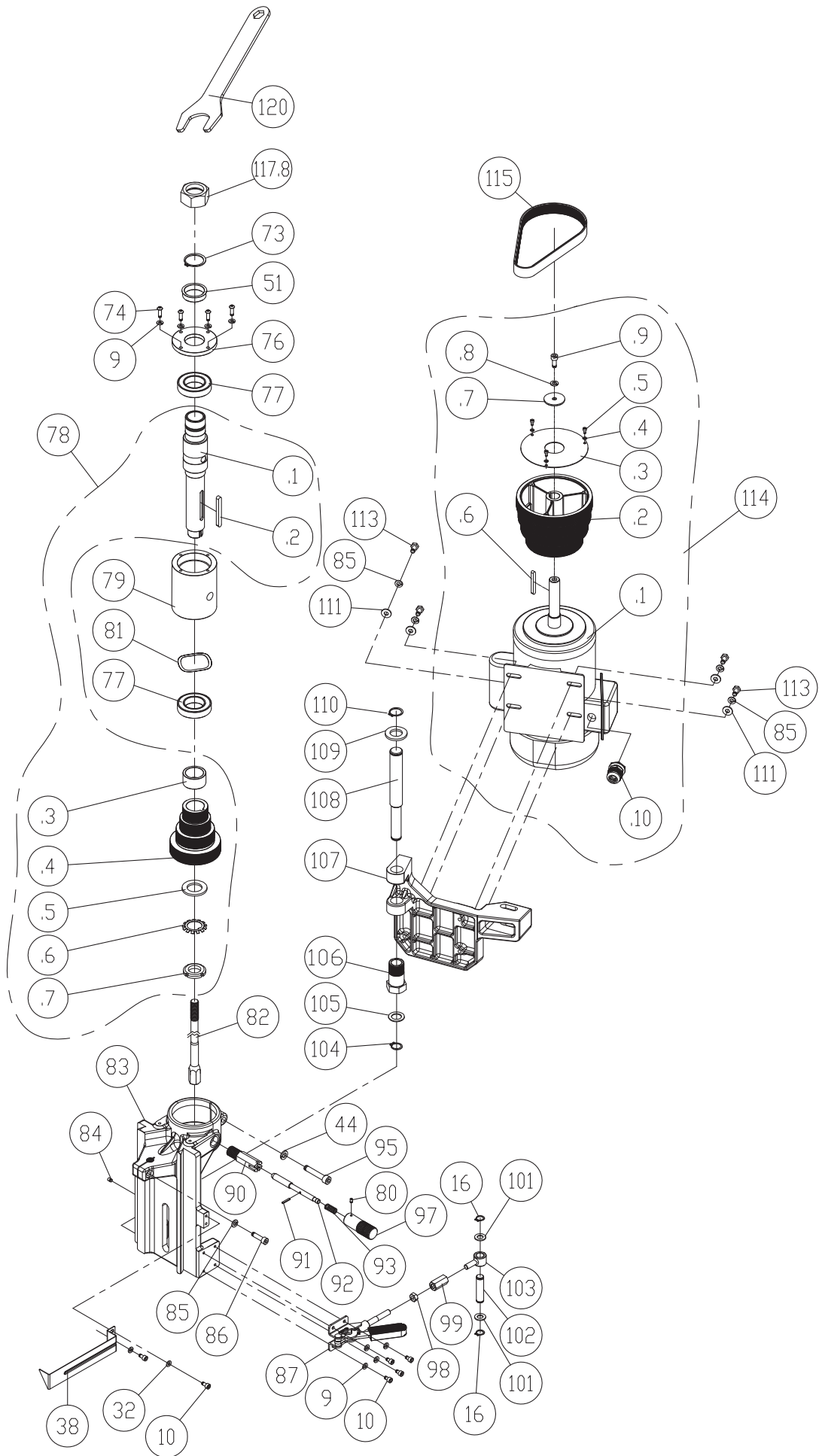

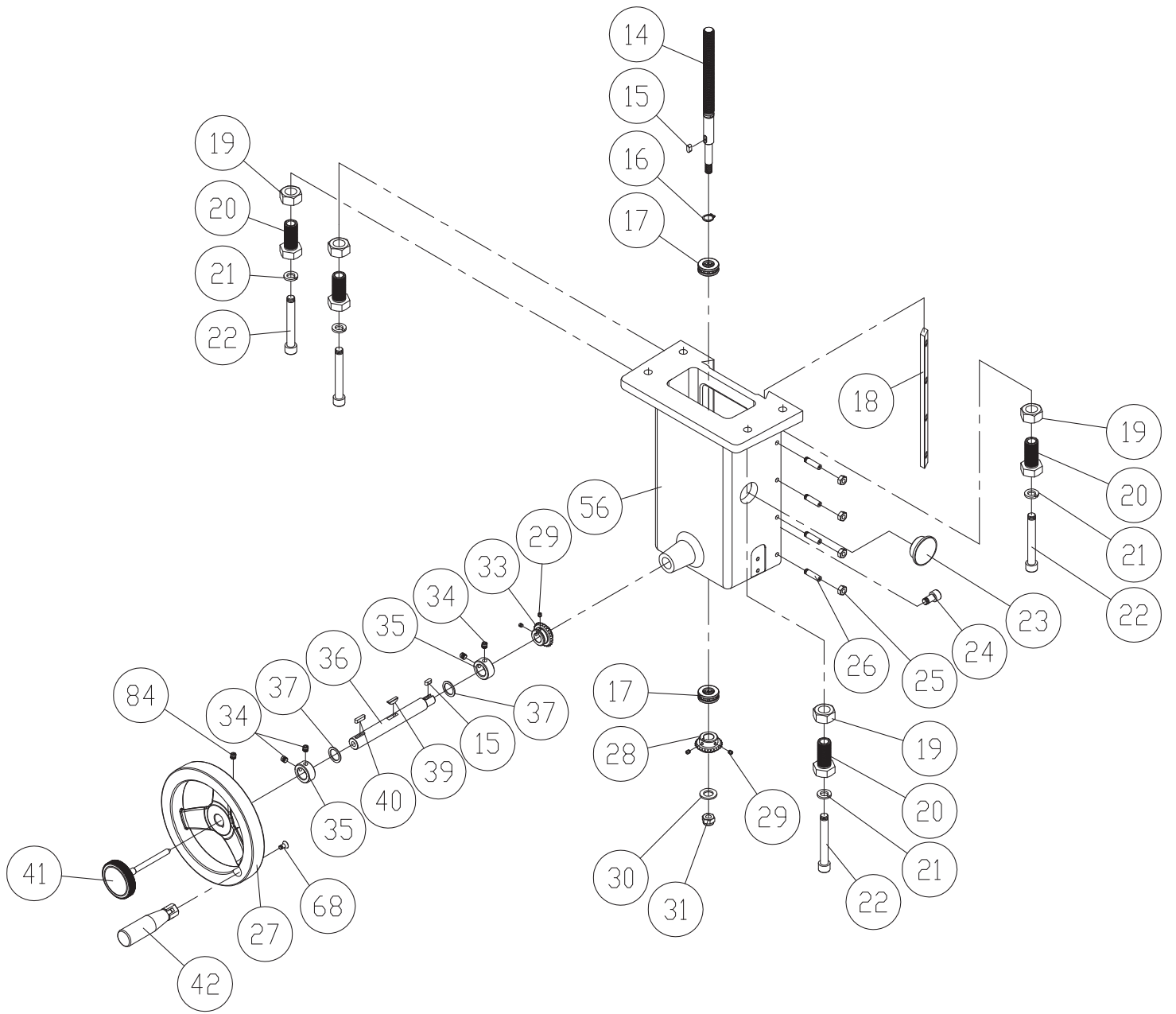

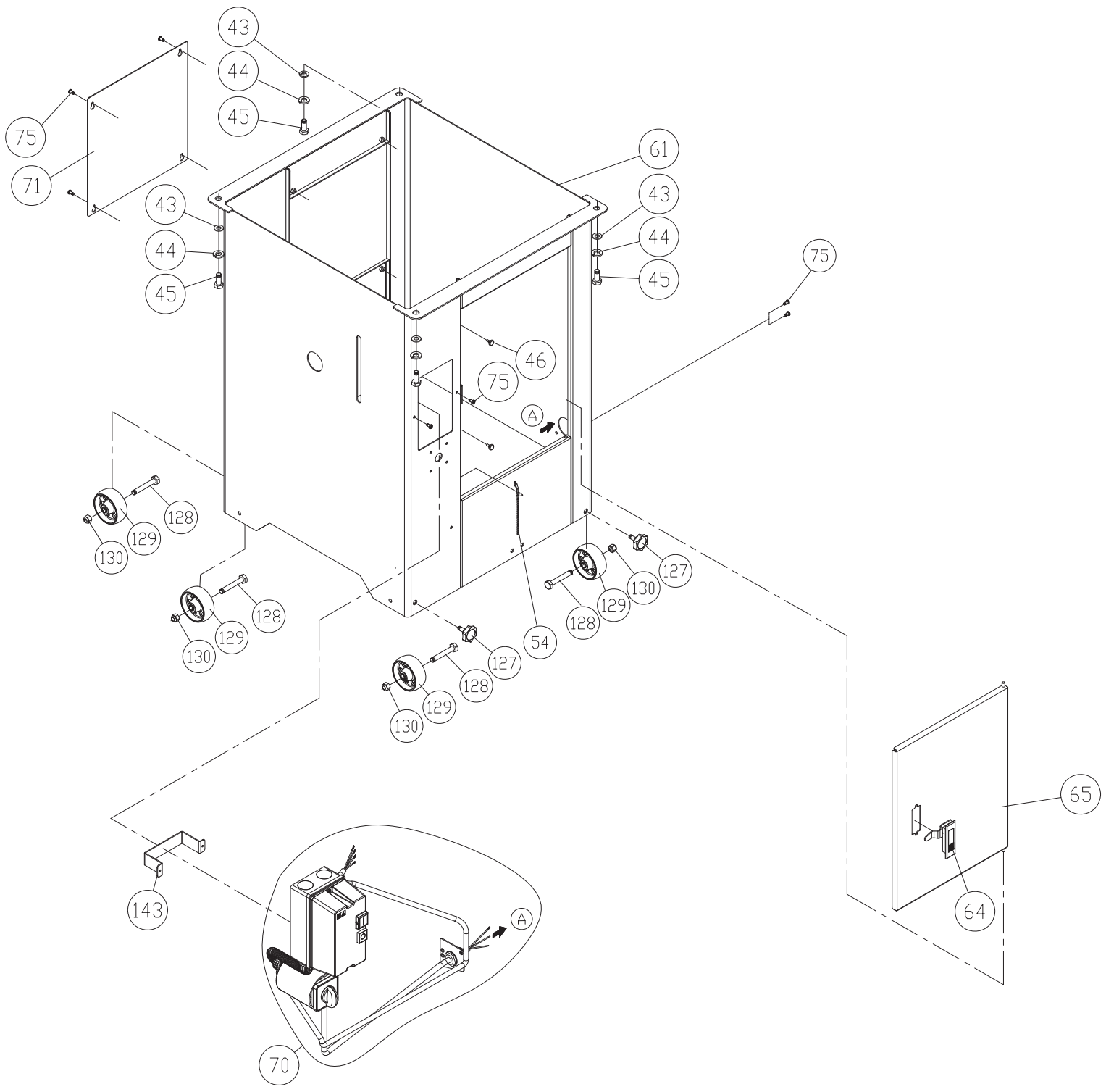

Parts List

Key	Part No.	Descriptions		Q'ty
1	230131-615	Knob	M6*1.0P	2
2	006001-036	Flat Washer	6.7*19*2.0t	2
3	300015-000	Cutter Guard Bracket		1
2	006001-036	Flat Washer	6.7*19*2.0t	2
4	250583-620	Cutter Guard		1
5	923273-000	Fence Bracket Assembly		1
5.1	001902-102	Set Screw	M6*1.0P*8	3
5.2	310160-911	Handle		1
5.3	006001-153	Flat Washer	13.5*30*3t	2
5.4	003007-304	Hex. Screw	1-2"-12NC*3"	2
5.5	230131-615	Knob		1
5.6	000302-102	Pan Head Screw	M4*0.7P*8	4
5.7	250693-615	Slot Bar		1
5.8	000303-106	Pan Head Screw	M5*0.8P*16	2
5.9	006001-155	Flat Washer	6*12*1t	4
5.10	310161-909	Bracket		1
5.11	000303-103	Pan Head Screw	M5*0.8P*10	1
5.12	310162-909	Scale		1
5.13	361014-901	Lead Screw		2
5.14	250695-621	Plastic Washer		2
5.15	300019-000	Bracket - Left		1
5.16	000203-104	Set Screw	M6*1.0P*12	4
5.17	006305-100	Spring Washer	8.2*15.4	1
5.21	008005-100	Hex Nut	M6*1.0P	1
5.22	000203-109	Set Screw	M6*1.0P*30	1
5.23	000104-104	Cap Screw	M8*1.25P*16	1
5.24	360855-000	Bracket Shaft		1
5.25	360857-901	Adjust Screw		1
5.26	230258-901	Position Set Screw	M8*1.25P	1
5.27	008006-100	Hex Nut	M8*1.25P	1
5.28	300020-000	Cutter Guard		1
5.29	190155-000	Dust Chute		1
5.30	006001-096	Flat Washer	13.5*32*3t	1
5.31	006708-100	Wave Washer	12.7*18.1	1
5.32	240080-904	Knob		2
6	250608-000	Feather Board	TS-35	2

Key	Part No.	Descriptions		Q'ty
7	922139-000	Table Assembly		1
7.1	002101-101	Flat Head Screw	M5*0.8P*20	3
7.2	050894-902	Insert Ring (Large)		1
7.3	050891-000	Table		1
7.4	001904-102	Set Screw	M4*0.7P*4	3
7.5	050893-902	Insert Ring (small)		1
8	360735-905	Draw Bar		1
9	006303-100	Spring Washer	6.1*12.3	8
10	000103-103	Cap Screw	M6*1.0P*12	6
11	172031-901	Bracket		2
12	001004-203	Carriage Bolt	M5*0.8P*30L	4
13	130233-903	Slide		2
14	360853-901	Lead Screw		1
15	012003-003	Key	5*5*12	2
16	010006-000	Retaining Ring	STW-15	3
17	031006-002	Bearing	51202	2
18	050696-000	Gib		1
19	008017-100	Hex Nut	M20*1.5P	4
20	380647-902	Adjust Screw	M20*1.5P	4
21	006308-100	Spring Washer	12.2*21.6	4
22	000106-112	Cap Screw	M12*1.75P*80	4
23	250159-615	Plug		1
24	002604-101	Pan Head Lock Screw	M10*1.5P*20	1
25	008006-100	Hex Nut	M8*1.25P	4
26	000204-109	Set Screw	M8*1.25P*40	4
27	240077-000	Handwheel		1
28	380767-000	Bevel Gear		1
29	001901-101	Set Screw	M5*0.8P*5	4
30	006003-079	Flat Washer	10.3*19*2.0t	1
31	008307-100	Lock Nut	M10*1.25P	1
32	006003-023	Flat Washer	6.3*13*2t	2
33	380768-000	Bevel Gear		1
34	004403-103	Set Screw	5/16"-18NC*5/16"	4
35	360376-901	Fix Ring		2
36	360721-901	Lead Screw		1
37	006006-106	Flat Washer	19.1*25.4*1.6	2
38	172321-156	Pointer		1
39	130061-000	Key		1

Key	Part No.	Descriptions		Q'ty
40	012003-007	Key	5*5*20	1
41	230256-916	Lock Handle		1
42	230046-000	Handle		1
43	006001-075	Flat Washer	10.3*22*2.0t	4
44	006307-100	Spring Washer	10.2*18.5	5
45	000004-202	Hex. Screw	M10*1.5P*25	4
46	340007-615	Spacer		2
47	000003-101	Hex. Screw	M8*1.25P*12	4
48	170448-901	Fence Blocl		2
49	006007-065	Flat Washer	9.2*20*2t	4
50	002201-201	Wood Screw	M6*2.6P*24	2
51	190164-901	Bushing		1
52	250593-615	End Cap		2
53	310159-909	Fence		2
54	230297-615	Clip		1
56	050692-008	Support		1
57	006001-127	Flat Washer	5.5*22*2.0t	8
58	230178-000	Lock Handle		8
60	001004-202	Carriage Bolt	M5*0.8P*16L	4
61	173264-000	Cabinet		1
64	230134-000	Latch		1
65	172841-000	Door		1
68	000702-102	Socket Hex. Screw	M6*1.0P*12	1
70	937991-001	Switch Assembly	3HP*1PH	1
71	173265-000	Side Cover		1
73	010025-000	Retaining Ring	STW-40	1
74	000801-104	Round Head Screw	M6*1.0P*20	4
75	000303-103	Pan Head Screw	M5*0.8P*10	8
76	050892-901	Bearing Cover		1
77	030203-002	Ball Bearing	6008	2
78	922483-000	Arbor Shaft Assembly		1
78.1	360913-901	Arbor Shaft		1
78.2	012005-010	Key	8*7*72	1
78.3	190154-901	Bushing		1
78.4	090216-000	Spindle Pulley		1
78.5	006003-147	Flat Washer	30.5*50*4t	1
78.6	006805-100	Lock Washer	ø30	1
78.7	008204-100	Lock Nut	M30*1.5P	1

Key	Part No.	Descriptions		Q'ty
79	051046-000	Cartridge		1
80	000203-102	Set Screw	M6*1.0P*8	1
81	006725-100	Wave Washer		1
82	380817-902	Connect Bar		1
83	050691-008	Arbor Shaft Bracket		1
84	001902-102	Set Screw	M6*1.0P*8	1
85	006305-100	Spring Washer	8.2*15.4	5
86	000104-110	Cap Screw	M8*1.25P*30	1
87	230125-000	Belt Tension Handle	GH-31501	1
90	380511-901	Connector		1
91	011002-105	Spring Pin	4*20	1
92	360724-901	Rod		1
93	280151-905	Spring		1
95	000105-106	Cap Screw	M10*1.5P*55	1
97	300013-000	Handle		1
98	008007-100	Hex Nut	M10*1.5P	1
99	380507-901	Hex Bushing		1
101	006001-125	Flat Washer	15.5*25*2.5t	2
102	360719-901	Connector		1
103	380513-901	Shaft		1
104	010010-000	Retaining Ring	STW-20	1
105	006001-142	Flat Washer	21*38*3t	1
106	380648-902	Adjustment Bolt	M30*1.5P	1
107	050890-000	Motor Bracket		1
108	360720-901	Shaft		1
109	006001-118	Flat Washer	25*44*4t	1
110	010011-000	Retaining Ring	STW-25	1
111	006001-054	Flat Washer	8.5*20*2.0t	4
113	000003-104	Hex. Screw	M8*1.25P*20	4
114	900820-000	Motor Assembly	3HP*1PH	1
114.1	603047-000	Motor	3HP*1PH	1
114.2	090217-000	Motor Pulley		1
114.3	172320-000	Motor Pulley Cover		1
114.4	006301-300	Spring Washer	4.1*7.7,	3
114.5	002605-101	Pan Head Lock Screw	M4*0.7P*8	3
114.6	012004-005	Key	6*6*55	1
114.7	006001-156	Flat Washer	8.2*40*3.0t	1
114.8	006305-300	Spring Washer	8.2*15.4	1

Key	Part No.	Descriptions		Q'ty
114.9	002601-102	Pan Head Lock Screw	M8*1.25P*20	1
114.10	021306-000	Strain Relief Bushing	PGA16-14B	1
115	014319-000	Poly V-Belt	610 J 10	1
116	921574-000	Miter Gauge Assembly		1
116.1	003303-105	Pan Head Screw	3/16"-24NC*3/8"	3
116.2	250193-620	Pointer		1
116.3	130053-901	Spacer		1
116.4	360381-901	Angle Set Bar		1
116.5	571151-000	Miter Scale		1
116.6	003305-106	Pan Head Screw	5/32"-32NC*5/8"	3
116.7	009001-100	Hex Nut	5/32"-32NC	3
116.8	290017-901	Shoulder Screw		1
116.9	230222-901	Ball		3
116.10	230300-615	Handle		1
116.11	006002-051	Flat Washer	8.5*18*3t	1
116.12	090067-008	Miter Gauge Body		1
116.13	380614-904	Slot Bar		1
116.14	380069-901	Ring		1
116.15	000403-105	Flat Head Screw	M6*1.0P*6	1
116.16	043311-000	O-Ring	P5	1
117	970310-000	1-1/4" Arbor Assembly		1
120	171895-904	Spanner	50mm	1
121	040401-000	Screw Driver	1*75	1
127	004001-101	Knob	5/16"-18NC*3/4"	2
128	003005-106	Hex. Screw	3/8"-16NC*2-1/2"	4
129	051068-000	Wheel		4
130	009102-100	Lock Nut	3/8"-16NC	4
133	240080-904	Knob		2
134	001902-102	Set Screw	M6*1.0P*8	2
135	040003-000	Hex. Wrench	3mm	1
137	361015-901	Angle Set Bar		2
139	006001-154	Flat Washer	13*25*2t	4
140	280159-000	Spring		2
141	009020-100	Hex Nut	1/2"-12NC	2
143	174710-902	Switch Bracket		1