

Planer

Model 10045

Owner's Manual

For Models Manufactured Since 05/2024



Oliver Machinery
1-800-559-5065
921 Thomas Ave SW
Renton, WA 98057

info@olivermachinery.net
WWW.OLIVERMACHINERY.NET

Stock Number: 10045.201
Manual Version: 1.0.0



READ AND UNDERSTAND ALL INSTRUCTIONS IN THIS MANUAL BEFORE ATTEMPTING TO ASSEMBLE OR OPERATE THE MACHINE.

FOLLOW THE INSTRUCTIONS AND THINK SAFETY!

THE OWNER OF THIS MACHINE IS SOLELY RESPONSIBLE FOR THE SAFETY OF ANYONE USING THIS MACHINE. SUCH RESPONSIBILITY INCLUDES BUT NOT LIMITED TO THE FOLLOWING:

- **PROPER ASSEMBLY, OPERATION, INSPECTION, MAINTENANCE, AND RELOCATION OF THE MACHINE.**
- **PROPER TRAINING FOR THE OPERATORS AND ENSURES THIS MANUAL IS AVAILABLE AT ALL TIMES.**
- **USAGE AUTHORIZATION.**
- **USAGE OF SAFETY AND PROTECTION DEVICE.**

OLIVER MACHINERY DISCLAIMS ANY LIABILITY FOR MACHINES THAT HAVE BEEN ALTERED OR ABUSED. OLIVER MACHINERY RESERVES THE RIGHT TO EFFECT AT ANY TIME, WITHOUT PRIOR NOTICE, THOSE ALTERATIONS TO PARTS, FITTINGS, AND ACCESSORY EQUIPMENT WHICH THEY MAY DEEM NECESSARY FOR ANY REASON WHATSOEVER.

**** SAVE THIS MANUAL FOR FUTURE REFERENCE. ****

PROP 65 NOTICE

WARNING: Drilling, sawing, sanding, or machining wood products can expose you to wood dust and/or other chemicals known to the State of California to cause cancer, birth defects, or other reproductive harm.

Some examples of these chemicals are:

- Lead from lead-based paints.
- Crystalline silica from bricks, cement, and other masonry products.
- Arsenic and chromium from chemically treated lumber.

Avoid inhaling wood dust and other harmful chemicals. Use a dust mask and other safety devices for personal protection.

For more information, go to <http://www.P65Warnings.ca.gov/wood>

Table of Contents

Introduction	5	Operation	28
Specifications	6	Step 1: Preparation	28
Identification	10	Step 2: Setting Depth of Cut	29
Safety	11	Step 3: Select Feed Direction	30
General Safety Guidelines	11	Step 4: Planing Wood to Desired Thickness.....	30
Safety Guidelines Specific to Planer	12	Common Wood Planing Problems	32
Electricals	14	Snipe.....	32
Minimum Circuit Size Required for Model		Chipping	32
10045 Planer	14	Indentation.....	32
Grounding.....	14	Grooves or ridges along the plane direction ...	32
Indoor Use Only.....	14	Fuzzy Grain	32
Electrical Wiring	14	Accessories	33
Setup	16	Cutter Inserts	33
Shop Preparation.....	16	Motor Carbon Brush	33
Space Requirement	16	Maintenance	34
Electricals	16	Maintenance Schedule	34
Lighting.....	16	Instructions for Maintenance and	
Safety Labels	16	Adjustments.... Error! Bookmark not defined.	
Dust Collection	16	Service Cutterhead and Rotate Cutter Inserts	35
Receiving	17	Inspect / Replace Poly V-Belt	36
Unboxing	17	Inspect / Replace Motor Carbon Brushes	37
Inventory.....	18	Inspect / Adjust Extension Wings	38
Assembly	19	Adjust Cutterhead Height Scale	39
Carriage Crank Installation	19	Adjust Carriage Elevation Chain Tension	39
DRO Installation	20	Troubleshooting	40
Dust Shroud Installation.....	21	Mechanical / Electrical Issues	40
Waxing.....	22	Finish Quality Issues.....	42
Dust Collection	22	Wiring Diagram	43
Bench Mounting (Optional).....	22	Parts List	44
Controls and Components	23	Carriage and Cutterhead Assembly	44
ON / OFF Switches.....	23	Motor Assembly.....	45
Overload Protection Reset Button	23	Body and Base Assembly	46
Depth of Cut Adjustment	23	Top and Carriage Lock Assembly	47
Carriage Lock	23	Maintenance Record	52
Feed Rate Selector	24	Notes	53
Material Removal Gauge.....	24	Warranty and Service	54
Depth of Cut Limiter	24	Appendix	55
Depth Stops.....	24	US Standard – Metric Conversion Chart	55
Digital Readout (DRO)	25		
DRO Calibration.....	25		
Components for Planing Wood.....	26		
Test Run.....	27		

Introduction

Thank you for choosing Oliver! This manual contains important information on safely setting up, operating, and maintaining this machine. Please take the time to read through this manual and make sure you understand all instructions.

While this manual may provide tips on optimizing the result of your workpiece, the manual is not intended as a substitute for formal woodworking training. If you need to know how to safely complete a woodworking task, please consult knowledgeable and qualified sources before proceeding further.

We made every effort to keep this manual up-to-date. Instructions, specifications, drawings, and photographs in this manual should match the machine delivered. If you find anything that seems confusing in this manual, or if some instructions are not available, please check our website for an updated manual:

WWW.OLIVERMACHINERY.NET/MANUALS

Alternatively, you can contact our technical support for help:

1-800-559-5065

Before calling, please note the manufacture date and the serial number. You can find the information on a nameplate on the back of the motor housing. The information allows the support staff to properly troubleshoot the issue and determine if an updated manual is available for your machine.

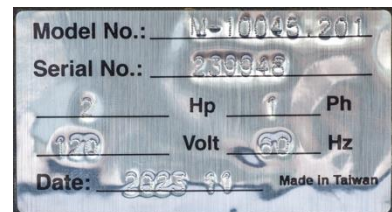

Please let us know how well this manual serves you. If you have any suggestions, please call the number above or email us at:

info@olivermachinery.net

We love to hear from our customers and make improvements.

Specifications

Quick View

Model	10045 Planer
Stock Number	10045.201
Motor	Universal Motor 2HP, 120V, 1Ph
Max. Stock Width	13"
Max Depth of Cut	1/64" (Full width) 1/16" (Stock less than 6" wide)
Dimensions	33-1/8"(L) x 24-3/4"(W) x 20-3/8"(H)
Footprint	14-1/4"(L) x 20-1/2"(W)
Fully Assembled Weight	74 lbs.
Warranty	1 Year (Motor and electronics) 2 Years (All other parts)

Product Dimensions

Width x Depth x Height (Fully Assembled)	33-1/8"(L) x 24-3/4"(W) x 20-3/8"(H)
Footprint	14-1/4" (L) x 20-1/2" (W)
Fully Assembled Weight	74 lbs.

Shipment Info

Package Type	Cardboard Box
Content	Planer with Included Accessories
Dimensions	Approx. 25" (L) x 17"(W) x 21"(H)
Weight	77 lbs.
Approximate Setup Time	30 minutes
Must Ship Upright	YES
Stackable	YES

Electricals

Power Requirement	120V, 1Ph, 60Hz
Full Load Current Rating	15A
Recommended circuit size	20A
Power Switch Type	Lockable paddle switch
Connection Type	NEMA 5-15 Plug
Overload Protection	Equipped

Motor

Motor Type	Universal Motor
Horsepower	2HP
Speed	20000 RPM
Efficiency	50%
Power Transfer Mechanism	Poly V-belt and pulleys
Bearing type	Permanently sealed ball bearing

Planer Capacity and Performance

Maximum Stock Width	13"
Maximum Depth of Cut	1/16" (Stock less than 6" wide) 1/64" (Full Width)
Maximum Stock Thickness	6"
Minimum Stock Thickness	5/32"
Minimum Stock Length	8"
Feed Rate	17 or 26 FPM
Number of Cuts Per Square Inch	144@17FPM 93@26FPM

Cutterhead and Carriage

Cutterhead Type	Oliver HCX Helical Shearing Cutterhead
Cutterhead Diameter	1-7/8"
Cutterhead Speed	10000 RPM
Number of Cutter Inserts	36
Number of Rows of Cutter Inserts	3
Cutter Insert Type	Four-sided, indexable carbide
Cutter Insert Diameters	15mm x 15mm x 2.5mm
Cutter Blade & Shear Angle	8.5 & 27.2 degrees
Cutter Insert Screw Tensioning Torque	30 lbs.-inch
Infeed Roller Type	Rubber
Outfeed Roller Type	Rubber
Carriage Height Change Per Turn of Crank	1/16"
Turret Depth Stop Precision	1/128"
Carriage Lock	Equipped

Measurements

Measurement Units	Inch/mm
Primary Measurement Device	Wixey Digital Readout
Digital Readout Resolution	1/32"/0.005"/0.1mm
Digital Readout Accuracy	+/- 1/500"/0.0025"/0.05mm
Additional Measurement Devices	Manual thickness scale Material Removal Gauge Turret Depth Stop Depth Stops

Table

Table Dimensions	33-1/8" x 13" (With extension wings) 10-1/4" x 13" (Without extension wings)
Material	Steel

Safety

Number of Dust Ports	1
Dust Port Size	4" (2.5" Adapter Included)
Minimum CFM Required	300 CFM
Sound Rating @ 2' distance	103 dB

Others

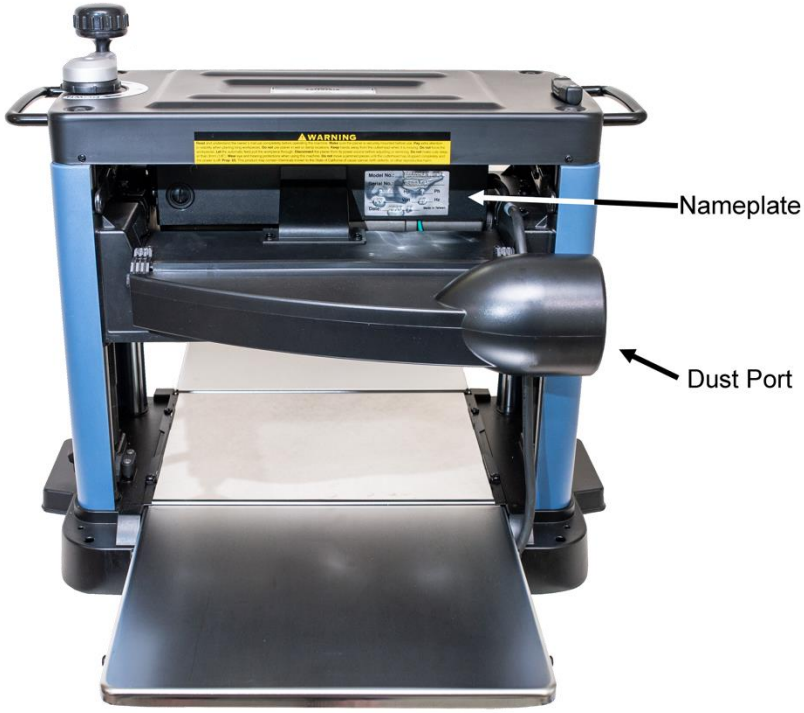
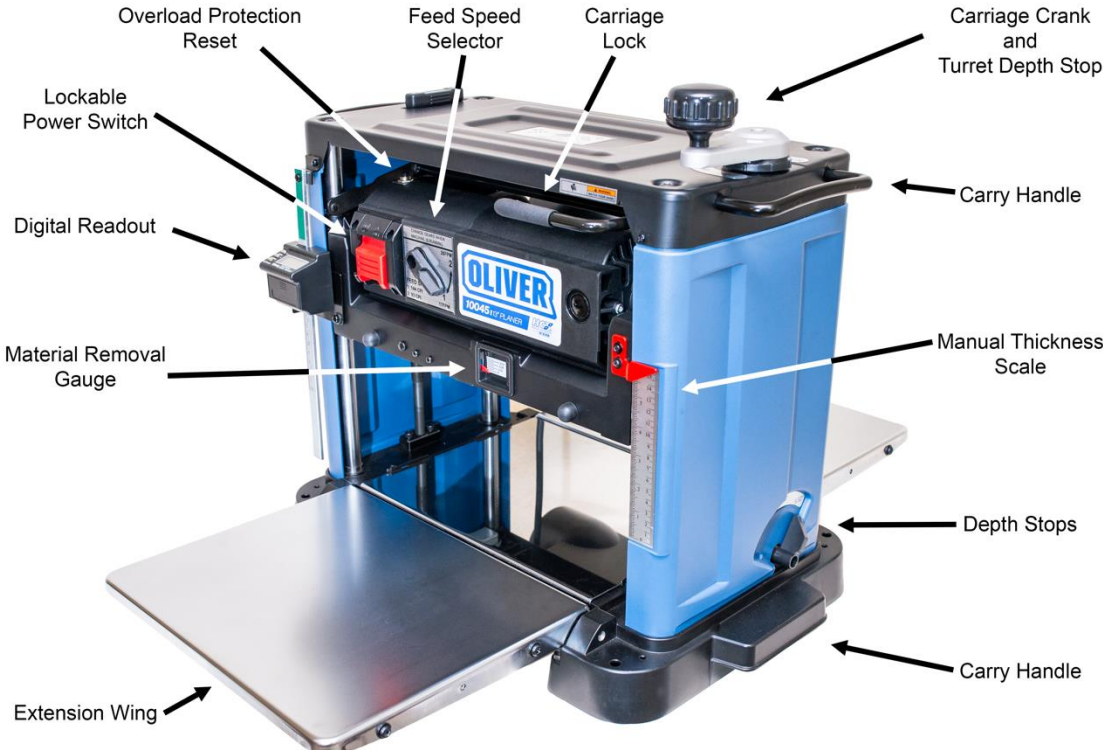

Serial Number Location	On the back of the motor housing
Spare Parts Included	5 Oliver HCX cutter inserts
Certification	CSA 175370
Country of Origin	Taiwan

Identification



Safety

Oliver Machinery has made every attempt to provide a safe, reliable, easy-to-use piece of machinery. Safety, however, is ultimately depending on the individual machine operator. **Before operating this machine, please become familiar with the following safety labels and guidelines.**

 DANGER	This indicates an imminently hazardous situation which, if not avoided, WILL cause death or serious injury.
 WARNING	This means if the warning is not taken seriously, it CAN cause death or serious injury.
 CAUTION	This means if the precaution is not taken, it MAY cause minor or moderate injury.
IMPORTANT	This is a tip for properly operating the machine to avoid machine damage.

General Safety Guidelines

1. **FAMILIARIZE** yourself with all safety instructions found in this manual. Know the limitations and hazards associated with this machine. Do not operate or service this machine until you are properly trained.
2. **ELECTRICAL GROUNDING**, when done properly, reduces the risk of electrocution, shocks, and fire. Make certain that the machine frame is electrically grounded and that a ground lead is included in the incoming electrical service. In cases where a cord and a plug are used, make certain that the grounding plug connects to a suitable ground. Follow the grounding procedure indicated in your area's electrical code.
3. **DISCONNECT** the machine from power before performing any service, maintenance, or adjustments. A machine under repair should be RED TAGGED to show it should not be used until the repair is complete.
4. **EYE PROTECTION**: Always wear an approved safety face shield, goggles, or glasses that comply with ANSI Z87.1 and CSA Z94.3 standards. Common eyeglasses are not safety glasses and may not provide adequate protection.
5. **EAR PROTECTION**: Use hearing protective devices where the noise exceeds the level of exposure allowed in Section 1910.95 of the OSHA Regulations. When in doubt, use it.
6. **OTHER PERSONAL PROTECTION**: Before operating this machine, remove tie, rings, watch, and other jewelry. Roll up sleeves above elbows. Remove all loose outer clothing and confine long hair. Wear professional work boots to protect your feet from injuries and slippage. Do not wear gloves unless it is instructed to perform a particular step(s) in the manual.
7. **GUARDS**: Keep machine guards in place for all applicable operations. If any guards are removed for maintenance, DO NOT OPERATE the machine until all guards are reinstalled.

8. **WORKPLACE SAFETY:** Keep the floor around the machine clean. Scrap material, sawdust, oil, and other liquids increase the risk of tripping or slipping. Be sure to clean up the table before starting the machine. Make certain the work area is well-lit and that a proper exhaust system is used to minimize dust. Use anti-skid floor strips on the floor area where the operator normally stands and mark off the machine work area. Provide adequate workspace around the machine.
9. **ACCESS CONTROL** should be enforced so only trained personnel can access the work area and operate the machine. Use a padlock to lock the power switch when the planer is not in use.
10. **STAY ALERT** at all times. Do not operate this machine while under the influence of drugs/alcohol or when not feeling well.
11. **NEVER STAND ON MACHINE.**
12. **REPLACEMENT PARTS:** Use only genuine Oliver Machinery replacement parts and accessories recommended for this machine. Generic parts made by other manufacturers may create a safety hazard and WILL void the factory warranty and other guarantees.
13. **PROPER USE:** Do not use this machine for anything other than its intended use. If used for other purposes, Oliver Machinery disclaims any real or implied warranty and holds itself harmless for any injury or damage which may result from that use.

Safety Guidelines Specific to Planer

Before Work Begins:

1. **USE ONLY NATURAL, SOLID WOOD.** Do not plane any material such as plywood, MDF, OSB, laminate, or anything that can disintegrate during operation. Do not plane treated lumber or anything that contains harmful chemicals, as this will spread wood dust that contains such harmful chemicals. Do not attempt to plane any workpiece with loose knots or with any other foreign materials.
2. **CHECK CUTTER INSERTS:** Make sure cutter inserts are sharp, clean, and free from damage. Forcing dull/damaged cutter inserts to work invites accidents and impacts finish quality. Use the recommended amount of torque to securely fasten all inserts onto the cutterhead.
3. **SERVICING CUTTER INSERTS:** Wear heavy-duty leather gloves to protect your hands when installing new cutter inserts or rotating the existing ones. Ensure the cutterhead is thoroughly clean before installing the insert. Debris between the cutter insert and its seat can create uneven pressure, causing the insert to break, and body injuries may occur.
4. **SUPPORT LONG WORKPIECE** with auxiliary stock feeding rollers/tables. This will help to avoid injuries and improve the quality of the finish. Bolt down the machine to prevent tipping.

When Using the Planer:

1. **DUST COLLECTION SYSTEM** is required for this planer. Please make sure the system is on and provide enough suction before starting the planer.
2. **KICKBACK** happens when a workpiece is ejected, usually towards the infeed side of the planer, during operation. **This can cause serious injuries or even death.** The operator should be cautious about possible kickbacks.
 - **ALWAYS** wear proper protection devices and stay away from the line of fire to avoid kickback-related accidents.
 - **NEVER** look inside the planer during operation.
 - **NEVER** plane boards that are shorter than 8", as mentioned in the specifications.
3. **PROPER WORKPIECE FEEDING** avoids kickback. Never start the machine with the workpiece engaging the cutterhead. Never start feeding until the planer has reached its full speed. Ensure feed rollers apply an adequate amount of pressure on the workpiece.
 - **NEVER** force a workpiece through the planer. Reduce the depth of cut as needed.
 - **ONLY** plane one board at a time.
 - For warped workpieces, face joint the workpiece with a jointer before planing.
4. **STUCK WORKPIECE** can only be removed after the planer is powered off and the cutterhead comes to a complete stop. Do not use hands or push sticks to force-feed a workpiece through the planer, as it can result in severe injuries and/or machine damage.
5. **DEPTH OF CUT SETTINGS:** Do not force the planer to exceed the maximum depth of cut capacity found in the specification. Failing to comply can cause machine damage and injuries. Reduce the depth of cut for hard materials as that increases the planer's workload.

After Operation

1. **STOP THE MACHINE** if the operator leaves the machine for any reason.
2. **WAIT** until the machine comes to a complete stop.
3. **CLEAN UP** the work area before departure.

Electricals



WARNING All electrical work must be done by a qualified electrician and must meet the electrical code in your area.

Minimum Circuit Size Required for Model 10045 Planer

<i>Stock Number</i>	Minimum Circuit Size Required
10045.201	20A

Please ensure the electrical circuit for this machine meets the minimum circuit size requirement. The minimum circuit size requirement applies to a dedicated circuit that provides power to one 10045 Planer. If more items are sharing the same circuit, consult a qualified electrician to ensure the designated circuit is properly sized for safe operation.

If a circuit is available but does not meet the minimum circuit size requirement listed above, a new circuit must be installed for this machine.

Grounding



WARNING Improper grounding can cause electric shock, fire, and equipment damage.

Proper grounding reduces the risk to the operator in the event of electrical malfunction or breakdown. This machine must be connected to the grounding conductor when available, and all grounding connections must meet or exceed the electrical code requirements in your area. Furthermore, all grounds must be verified and must meet or exceed the electrical requirement of the machine. If grounding is not available, consider the use of a GFCI protection device as an alternative if this complies with the electric code in your area.

Indoor Use Only

This machine is designed for indoor use only. Operating this machine outdoors increases its exposure to moisture, which in turn increases the risk of electric shock.

Electrical Wiring

This machine is pre-wired for 120V with a cord and plug. Using an extension cord to bring power to the planer is not recommended. If you must use an extension cord to connect to a power source, select a durable cord type with a high-temperature rating (90C° or above). Use the minimum amount of extension cord as needed.

Minimum cord size (AWG) required based on amperage draw and length of the cord:

Amps	Power Cord Length				
	25 feet	50 feet	75 feet	100 feet	> 100 feet
< 5	16	14	14	14	NR
5 to 8	14	14	14	12	
8 to 12	14	14	12	10	
12 to 15	12	12	10	10	
15 to 20	10	10	10	NR	
21 to 30	10	NR	NR	NR	

*NR: Not Recommended

 WARNING	<p>Use properly sized wires that meet or exceed the power requirement of your machine. Using undersized wires may cause overheating and increase the risk of fire and machine damage.</p>
---	--

Setup

Shop Preparation

Space Requirement

The dimensions of this machine are 33-1/8" (L) x 24-3/4" (W). You will need additional space to manipulate your workpiece and connect to the dust collection systems.



Electricals

If you plan to install this machine in a permanent location, make sure a properly sized circuit and electrical outlet are available nearby. Please refer to "Electricals" on page 6 for details regarding electrical requirements.

Lighting

Adequate lighting is needed to operate this machine. Overhead, non-glare lighting should be installed.

Safety Labels

If this machine introduces a new safety hazard to your workplace, display proper warning signs in highly visible locations.

Dust Collection

Wood dust created by this planer is a health hazard. Position this planer in a spot where it has access to a dust collection system.

Dust masks should be available for using the planer.



CAUTION

Use a dust collection system that is rated above 300 CFM. Doing so improves air quality in the workplace and prevents the machine from jamming.

When the machine is further away from the duct collector, the effective suction and CFM measured at the dust ports decrease. Ensure there is significant suction at the dust port so dust and debris can be effectively removed from the machine.

Receiving

If this planer is delivered to you, please check for any significant damages on the packaging before signing the delivery confirmation.

This machine has a shipping weight of 77 lbs. and a net weight of 74 lbs. Please be sure help is available to move the machine to its final location.



IMPORTANT

If items are damaged, please call us immediately at **1-800-559-5065**



10045 Planer has a gross weight of 77 lbs. and a net weight of 74 lbs.

Safe moving techniques and proper lifting equipment are required, or serious personal injury may occur.



Do not lift your shipment by the strap. The straps are not designed to hold the total weight of your shipment. They may snap without warning and cause serious injury and machine damage.

Straps may spring back violently when released and cause injury. Always wear safety goggles and gloves when removing the straps.

Unboxing

Inside the box, you should find the planer and a box that contains all loose parts and accessories.



Inventory

Carefully unwrap the packaging and make sure all components are included in the shipment. Lay out all items received and inventory them.

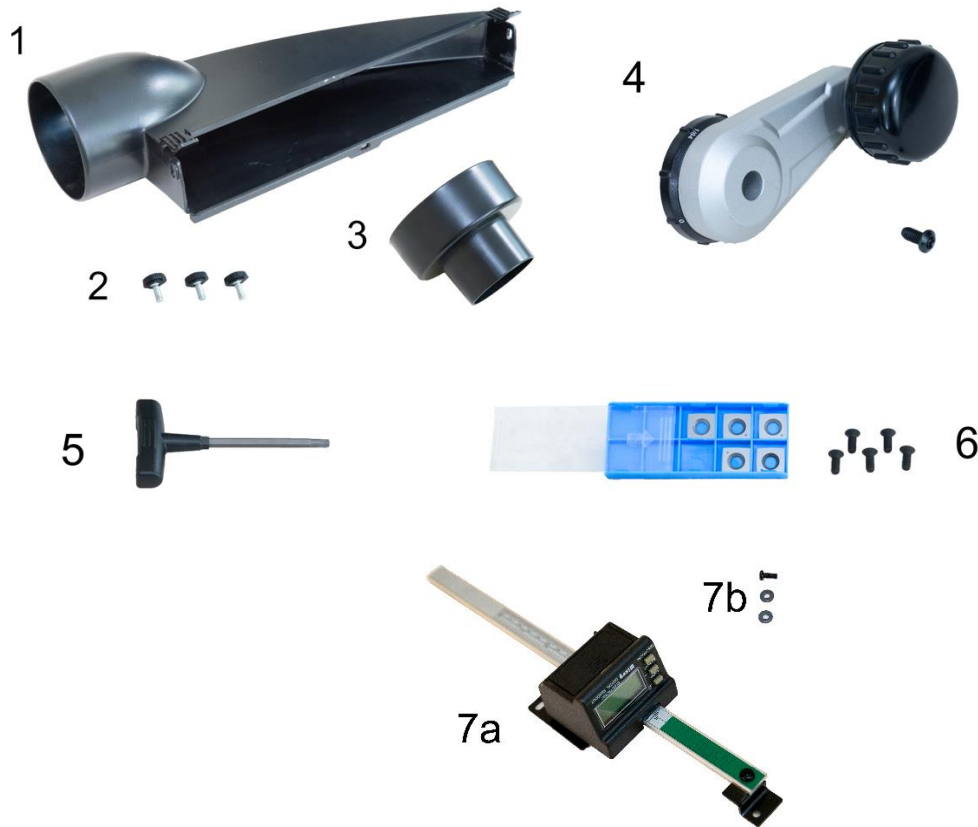

<i>Item</i>	<i>Description</i>	<i>Quantity</i>
1	Dust shroud with 4" dust port	1
2	Thumbscrews for mounting the dust shroud	3
3	2.5" Dust port adapter	1
4	Carriage crank and mounting screw	1 each
5	T30 Torx Wrench	1
6	Spare cutter inserts and mounting screws	5 each
7a	DRO Assembly	1
7b	DRO Philips Screw	1
	Washers	2

NOTICE: If you cannot find an item in the list above, please check if it is still attached to the packaging. Occasionally, the item may have been pre-installed in the factory. See "**Parts List**" on page 44 to check if a component is included or installed.

NOTICE: This machine comes with various standard-sized, non-proprietary parts that can be purchased at local hardware store. If any of these parts are missing, getting them from the local store is the fastest way to get the machine running. We can also deliver any missing parts.

Additional Items Recommended for Machine Assembly and Maintenance

Item	Purpose
Safety glasses	Protection.
Disposable gloves	Protection.
Straight edge	Check alignments.
T-25 Trox driver bit	Cutter inserts rotation/replacement (30 lbs.-inch).
Torque wrench/screwdriver	Cutter inserts rotation/replacement (30 lbs.-inch).
4mm Hex Wrench	Cutter inserts rotation/replacement (30 lbs.-inch).
10mm Wrench (1 pair)	Extension wing adjustment.
Philips Screwdriver	General maintenance.

Assembly

This planer is mostly assembled in the factory. There are a few more items to set up before the machine is ready for a test run:

1. Install the carriage crank.
2. Install the DRO battery.
3. Install the dust shroud.
4. Connect the planer to a dust collection system.

The approximate time for cleaning and assembly is approximately 30 minutes.

Carriage Crank Installation

1. Install the crank. Make sure the flat surfaces on the crank and the shaft are aligned.
2. Secure the crank with a T-30 Torx screw and the matching T-handle that comes with the package. A T-30 Torx wrench can be pulled out from the top panel for this task.

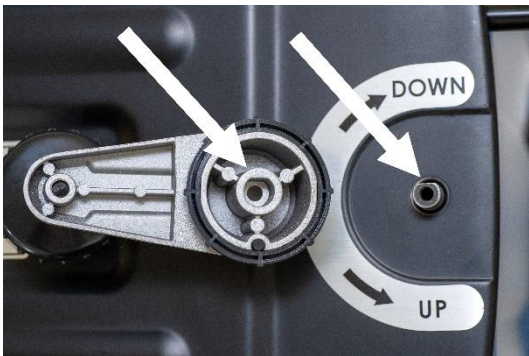

DRO Installation

1. To protect this precision instrument, the DRO assembly is shipped in a separate package.
2. Remove the top cover screw on the left side, then use the same screw to mount the top DRO bracket. Do not fully tighten the screw yet.
4. Move the carriage to the highest position, then back to the lowest position. Ensure the DRO body glides along the scale smoothly, then tighten the mounting screws.
5. Remove the battery cover and install two AAA batteries. Reinstall the cover when done.

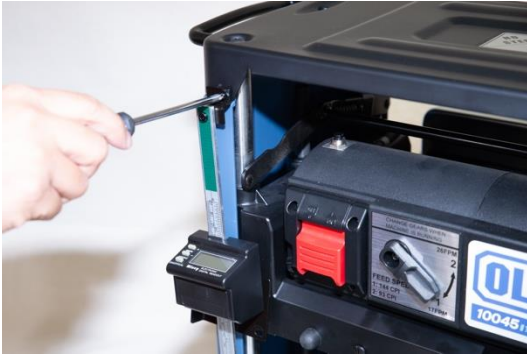

3. Move the carriage to the lowest position. Then mount the DRO body bracket onto the carriage using the provided Philips screw. Shim both sides of the bracket with the washers provided. Do not fully tighten the screw yet.

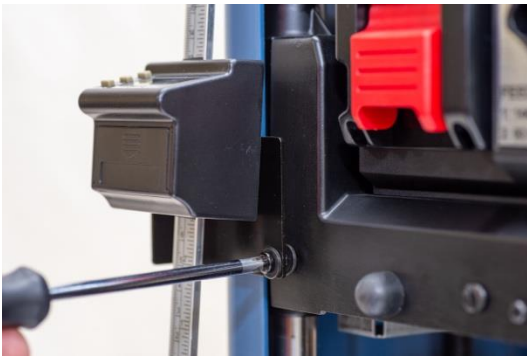

Dust Shroud Installation

1. Check the dust shroud and empty out any packaging and loose parts.

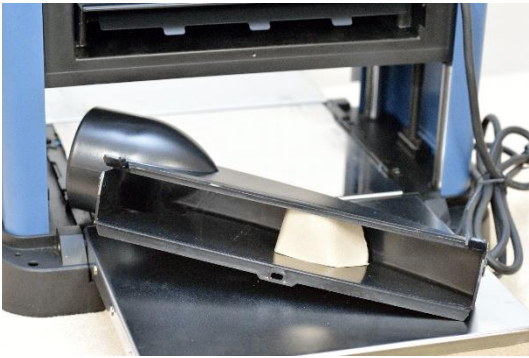

2. Attach the dust shroud onto the cutterhead cover plate.



3. Use the provided thumb screws to secure the dust shroud at the bottom and on each side.

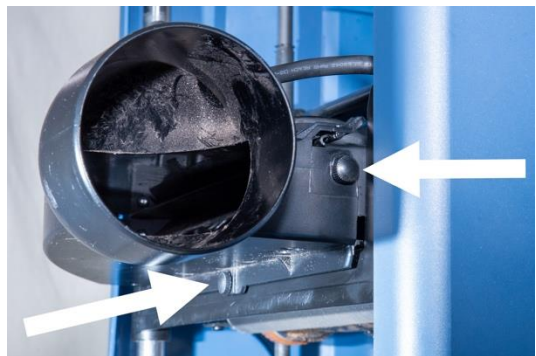
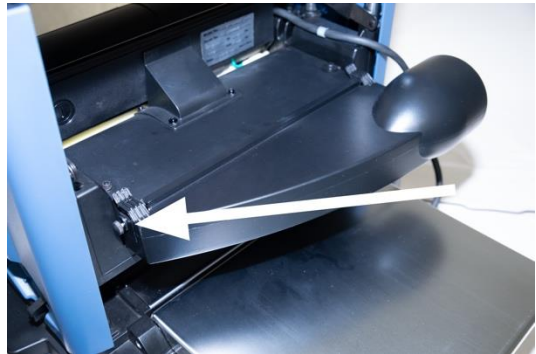

4. (Optional) Install the 2.5" dust port adapter to connect the planer to a vacuum.



Waxing

The surfaces of the steel planer bed and extension wings have a low-resistance finish. To minimize stock feeding resistance, wax these surfaces with paste wax before first use and routinely thereafter.

Dust Collection

This wood planer can generate a lot of wood shavings and dust. Although this planer is equipped with an internal dust blower, it is still a good idea to connect this planer to a dust collection system so all dust and wood chips can be effectively removed and contained.

The minimum CFM requirement for this planer is 300 CFM at the dust port, which means your dust collection system should have a rating greater than 300 CFM, as air friction and leakage reduce effective CFM at the dust port.

This planer comes with a 2-1/2" dust port adapter, which is compatible with a standard-sized vacuum hose. It is possible to connect this planer to a vacuum with good suction for light-duty tasks.

IMPORTANT

Running this planer without a dust collection system or using a dust collection system with inadequate suction may cause dust and shavings to accumulate inside the planer. This can damage the machine and cause other hazardous situations. Check your dust collection system regularly to make sure it is not jammed or filled up.

When using this planer without a dust collection system, clean the planer frequently so wood chips do not accumulate inside the machine.

Bench Mounting (Optional)

Mounting this planer on a stable surface prevents it from tipping. The diagram below has the measurements of the planer base and the mounting holes. Using four 5/16" bolts for mounting provides maximum strength and stability. Alternatively, there is another set of four mounting holes that accept screws up to size #10.

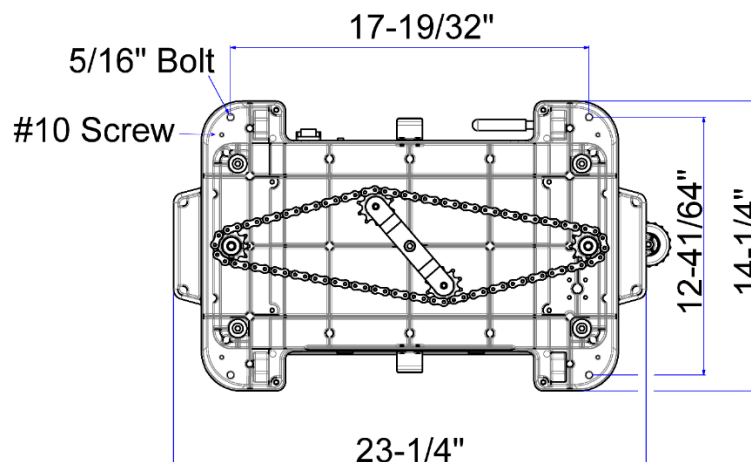

Controls and Components

ON / OFF Switches

- To start this planer, lift the power switch paddle.
- To stop, press the paddle down.

NOTICE: This power switch can be locked with a padlock. Lock the power switch to protect unexpected guests from getting injured.



Overload Protection Reset Button

The overload protection button is on the top left side of the carriage. If the planer is overloaded and stopped, **the reset button will pop up**. Wait for 3 minutes for the machine to cool down. Reduce workload, then press the reset button before resuming operation.



Depth of Cut Adjustment

This planer has a carriage crank and a turret depth stop attached. Each turn of the crank changes the depth of cut by 1/16".

- Turn clockwise to lower the cutterhead and increase the depth of cut.
- Turn counterclockwise to raise the cutterhead and reduce the depth of cut.

Use the turret depth stop to make fine depth of cut adjustments. Each notch on the scale represents 1/128" of changes.

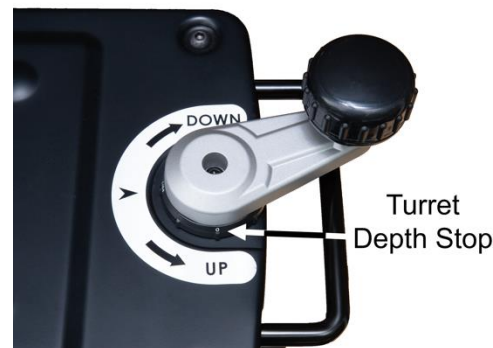

Carriage Lock

The carriage lock lever is on the top right side of the carriage.

- Lower the lever to **LOCK** carriage height.
- Lift the lever to **UNLOCK**.

TIP: Planing with the carriage lock engaged can reduce snipe.



Feed Rate Selector

10045 planer can feed stock at 17 or 26 FPM (feet per minute). The high feed rate allows faster processing time for milling stock to approximate thickness. Use the low feed rate to create a fine finish.

To change the feed rate, turn on the planer and wait for the motor to come to full speed, then flip the selector and set the feed rate.



IMPORTANT

Only change the feed rate when the machine is running at full speed. Failure to do so may cause the gearbox to jam and damage the machine.

Material Removal Gauge

The material removal gauge shows the amount of stock to be removed. The sensor is located below the three screws as shown in the picture.

Depth of Cut Limiter

The depth of cut limiter is in front of the planer carriage. This non-moving part protects the motor from overloading by limiting the depth of cut of wide stock to 1/64".

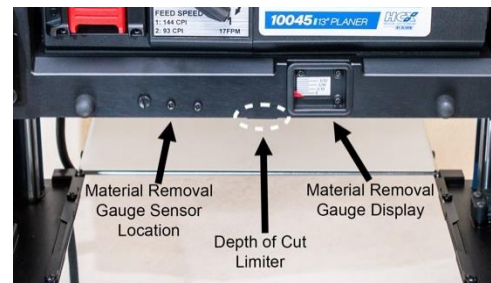

Depth Stops

Allows quick and repeatable adjustments for thickness planing. Four settings are available: 5/32", 1/4", 1/2", and 3/4".

To plane stock to the thickness of the above:

1. Raise the carriage above the desired thickness setting.
2. Move the depth stop lever to the desired thickness setting.
3. Lower the carriage until resistance is felt when turning the carriage crank.



IMPORTANT

Do not force the carriage to go below the height limited by the depth stop. Permanent planer damage may occur, and the workpiece planed may have one side thicker than another.

Digital Readout (DRO)

This planer is equipped with a Wixey DRO with 0.005" or 1/32" resolution. A fractional inch value will appear if the measurement is a multiple of 1/32.

MM/IN Button

Toggle measuring unit between metric (mm) and US standard (inch).

ABS/INC Button

Toggle between absolute mode and incremental mode.

The absolute mode shows the thickness of the workpiece after it is planed. Once calibrated, the settings will be memorized unless the battery is exhausted.

The incremental mode shows the distance the cutterhead traveled from the last reset position. The reading can be reset by toggling to absolute mode.

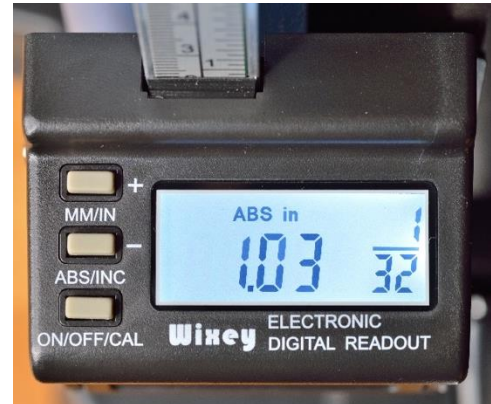

ON/OFF/CAL Button

This is the DRO power switch. Hold the button to calibrate the DRO.

DRO Calibration

Prepare a piece of flat scrap wood and a caliper for calibration.

1. Plane down the scrap wood until the entire surface is cut.
2. Using a caliper, measure the thickness of the midsection of the workpiece. Note down the thickness.
3. Turn on the DRO and switch to ABS mode.
4. Hold the **ON/OFF/CAL** button for 3-5 seconds. "ABS" will blink on the display when the DRO enters calibration mode. The reading of the absolute mode is now reset to zero.
5. To set the reading of ABS mode, press "+" (MM/IN button) or "-" (ABS/INC button) to enter the measurement taken in step #2. Hold the button to quickly increment/decrement the reading.
6. Press the ON/OFF/CAL button when the value is set. This will exit the calibration mode.
7. Once the DRO is calibrated, the DRO will memorize the value until the battery is exhausted.

Components for Planing Wood

This diagram shows the components involved in planing a piece of wood:

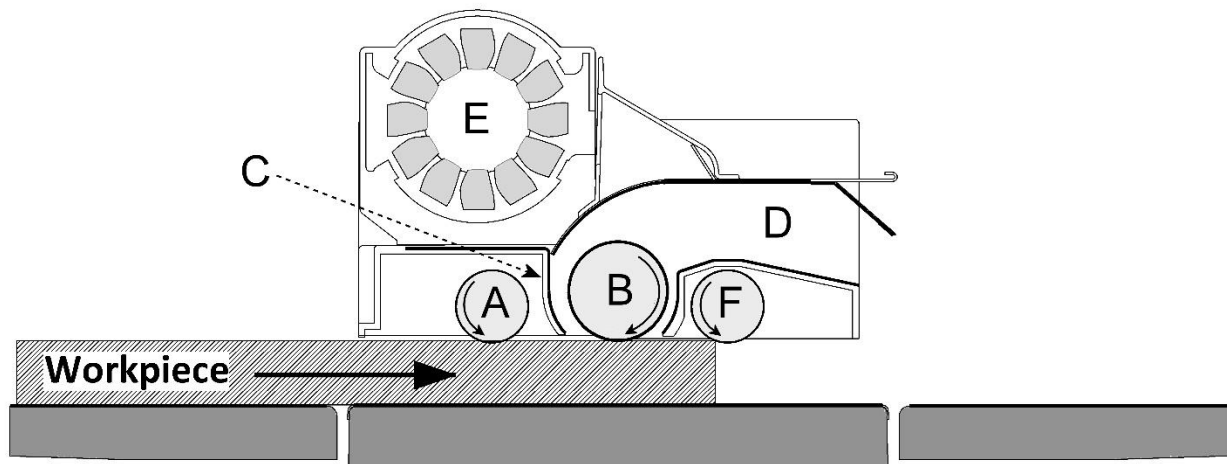

How it works:

1. When the workpiece enters the planer, the infeed roller [A] pulls the workpiece towards the cutterhead [B].
2. Cutterhead then planes the workpiece to the desired thickness.
3. Wood chips and dust generated by the cutterhead are collected by the chip breaker [C] and diverted toward the dust shroud [D]. An internal chip blower [E] then pushes the debris out of the dust shroud.
4. As the workpiece moves past the cutterhead, the outfeed roller [F] pulls the workpiece away from the planer.

Test Run

To familiarize yourself with this planer and ensure everything is well-calibrated, you are advised to run the following tests before production work.

Step 1: Verify all electrical components are functional.

1. Remove all tools and debris from the planer bed and the extension wings.
2. Make sure the power switch is in the OFF position.
3. Connect the machine to the power source.
4. Flip the power switch to ON. The planer should start running with no excessive vibration or high pitch noise.
5. Flip the power switch to OFF to stop the machine.

Step 2: Verify that the planer is functional and calibrated.

1. Connect the planer to a dust collection system.
2. Move the carriage to the lowest position. The carriage should stop at the 5/32" mark as shown on the manual thickness scale or the height set by the depth stop.
3. Raise the carriage all the way up. It should stop approximately at the 6" mark on the manual thickness scale.
4. Turn on the DRO and check its readings. It should reflect the movements of the carriage.
5. Prepare a piece of good quality, straight-grain wood board with a flat bottom for a test run. It is advised to choose a board that is close to 13" wide and at least 2 feet long.
6. Start the dust collection system.
7. Set the depth of cut to approximately 1/64" for a test pass.
8. Lower the carriage lock lever. The carriage should not move when attempting to adjust its height.
9. Turn on the planer and begin feeding the workpiece. Feed rollers should pull the workpiece through the planer. Verify the entire top surface is cut.
10. Turn off the planer and inspect the workpiece for any defective finish.
11. Using a caliper, check that the workpiece thickness is uniform side-to-side and front-to-back. This ensures the cutterhead is parallel with the planer table.
12. Check the cutterhead height scale. It should point at the same value as shown on the caliper.
13. Check for excessive snipes. A minimum amount of snipe may occur at the ends of the board, and it is expected.

Congratulations! You have completed the test run, and your planer is ready for production work. If you discover any issues from the tests, please refer to the troubleshooting section and maintenance section to diagnose issues and make adjustments.

Operation

For safety and to achieve the best results, please take the following steps before processing any workpiece with this planer.

Step 1: Preparation

Only Use Natural and Quality Wood

Only plane good quality natural wood materials. Cracked stock, boards with loose knots, plywood, and other engineered wood products can break apart and cause severe kickbacks, which can lead to severe injuries and machine damage.

Do not plane treated lumber or anything that contains harmful chemicals, as this will spread wood dust that contains such harmful chemicals. NEVER plane boards that are shorter than 8", as mentioned in the specifications.

Inspect the Workpiece

Carefully inspect the workpiece for foreign objects. Nails, staples, rock chips, and other objects embedded on the wood surface will damage the planer. To avoid chipping or dulling the cutter inserts, clean the workpiece with a stiff brush to remove all dirt and foreign objects before planing, especially for rough-sawn or reclaimed lumber. Use a metal detector to scan for metal objects as needed.

Check Moisture Content

Check moisture content before the operation. "Green wood" with moisture content over 20% will not cut properly and may jam the machine. Excessive moisture content will also cause the planer's unpainted surface to rust. Besides, as the workpiece dries, the once-flattened surface can become fuzzy and warped again. Allowing a workpiece to dry and stabilize before it is processed is recommended.

Warped Stock

Boards with moderate cupping, bowing, or twisting should have one side face-jointed before being processed by a planer. It is acceptable to process a slightly cupped board. Make sure the cupped side is facing down, and begin with light cuts.

Avoid using boards with severe warping, as they can be unstable and might cause severe kickbacks during operation.

Glue Deposits

Glue left on the workpiece surface can dull cutters and impact cut quality. Scrape off all glue deposits from the workpiece before the operation.

Wood Grain Direction

This planer is designed to plane WITH the grain direction of the wood. Do not plane cross-grain or end-grain. Severe kickback and chipping may occur.

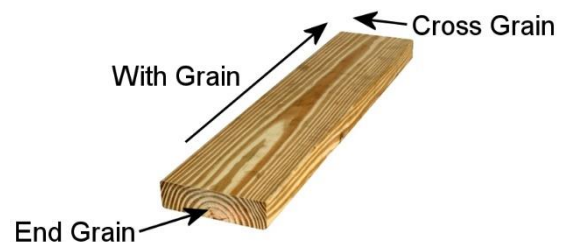

Step 2: Setting Depth of Cut

This planer can remove at most 1/16" of materials per pass. For stocks that are over 6" wide, the planer can remove at most 1/64" of materials per pass. For best results, take light passes and reduce the feed rate when approaching the desired thickness.

To make small depth of cut adjustments, use the turret depth stop located at the base of the carriage crank. Each notch on the turret depth stop represents 1/128" of changes. The turret depth stop can be turned individually from the crank so the notch can align with the pointer when making adjustments.

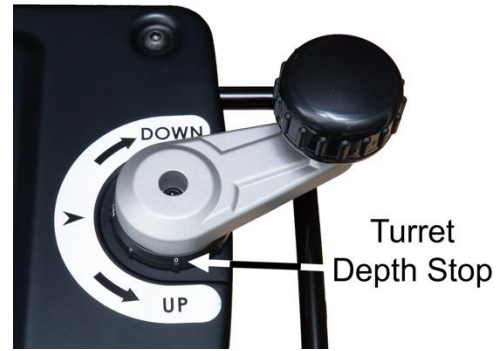

Wood Hardness

Reduce the maximum depth of cut for wood types that are extremely hard or extremely soft. Hardwood increases the planer's workload, and very soft wood species may get a poor finish when receiving aggressive cuts.

For your reference, this Janka scale shows the hardness of wood types that are commonly used. It ranks the hardness of various wood types by measuring the amount of force (in lbs.) required to embed a 0.444" steel ball halfway into the wood.

Janka Wood Hardness Scale

BALSA	70
EASTERN WHITE PINE	380
BASSWOOD	410
WHITE PINE	420
HEMLOCK	500
CHESTNUT	540
RED ALDER	590
DOUGLAS FIR	660
SYCAMORE	770
CEDAR	900
CHERRY	995
BLACK WALNUT	1010
TEAK	1155
RED OAK	1290
WHITE ASH	1320
WHITE OAK	1360
HARD MAPLE	1450
ZEBRAWOOD	1575
WENGE, RED PINE	1630
PADAUK	1725
ROSEWOOD	1780
PURPLE HEART	1860
RED MAHOGANY	2697
EBONY	3220
IRONWOOD	3260
IPE	3684

Maximum Depth of Cut

Based on Douglas Fir hardness. Harder woods and wider stock require more passes to remove the same amount of material.

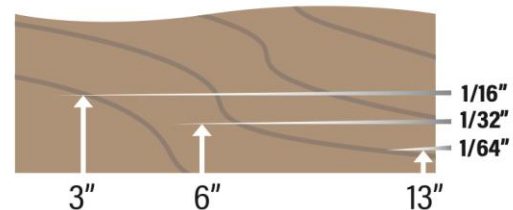

3" width boards 1/16" max cut depth
 6" width boards 1/32" max cut depth
 13" width boards 1/64" max cut depth

Step 3: Select Feed Direction

Inspect the workpiece and identify the direction of the edge grain. Choose a feed direction such that cutters will cut WITH grain to minimize tearouts.

Good – Planer cuts WITH the grain.

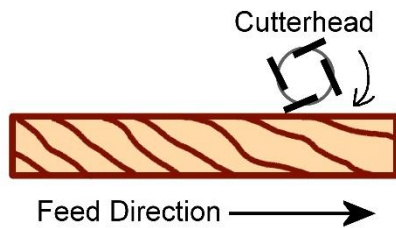

Not Ideal – Planer cuts AGAINST the grain.

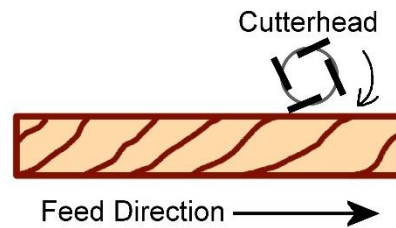

Sometimes, it is impossible to cut with the grain for the entire length of a workpiece. In this case, try feeding the workpiece in the opposite direction and see what works best. Reducing the depth of cut can also help improve cut quality.

Step 4: Planing Wood to Desired Thickness

With the above preparation steps completed, the workpiece is ready for planing.



WARNING

Always wear goggles and other protective devices when operating this machine. Stay on the side of the planer to avoid kickback-related accidents. NEVER look inside the planer during operation. Failing to comply may result in serious injuries or death.



CAUTION

Use an ear protection device to prevent hearing loss. Ensure the dust collection system is functional, and use a dusk mask to avoid inhaling harmful airborne particles.

1. Put on protection devices.
2. If you have a long workpiece, make sure it is properly supported throughout the process. Bolt down the planer on a stable surface as needed.
3. Measure the workpiece thickness and set the initial depth of cut to no more than 1/32". This allows feed rollers to properly engage the workpiece and, at the same time, not taking too much material off for a test pass.
4. Lock the carriage to minimize snipe.
5. Turn on the dust collection system and planer.
6. While standing on the side of the planer, gently feed the workpiece with the face jointed side down. Once the infeed roller engages the workpiece, allow the machine to feed the workpiece. **DO NOT** force feed the workpiece through the planer.

If the infeed roller does not engage the workpiece:

- Carriage height is set too high.
- Stop the machine and wait for it to come to a complete stop, then remove the workpiece.
- Lower carriage height and restart from step 4.

If the machine stalls or the workpiece gets stuck:

- Carriage height is set too low.
 - Stop the machine and wait for it to come to a complete stop, then remove the workpiece.
 - Reduce the depth of cut, and restart from step 4.
7. If the workpiece is feeding properly, wait until the entire workpiece clears the outfeed roller, then remove the workpiece.
 8. After the initial pass, measure the workpiece thickness in the midsection.

If more material needs to be removed, continue with the following steps.

9. If you need to remove a lot of material, run a few passes with deeper cuts, then finish with a light pass with shallow cuts.
10. The depth of cut for each pass should be less than 1/64". For workpieces 6" wide or less, the depth of cut can be as much as 1/16". Reduce the maximum depth of cut for harder wood types. Use DRO or the depth gauge on the carriage elevation crank to measure the depth of cut.
11. Repeat until the workpiece is plane down to the desired thickness.

Turn the machine off when the operation completes.

Common Wood Planing Problems

Snipe

When a workpiece is not properly supported as it enters or leaves the machine, the ends of the workpiece will have more materials removed than the rest of the section. To mitigate this problem, hold the workpiece up slightly as it enters and leaves the machine. Sometimes, a small amount of snipe is inevitable. The best way to eliminate snipes completely is to prepare a workpiece of extra length and then trim the ends when the planing is done.



Chipping

Happens when cutting against the grain direction. See "**Select Feed Direction**" in this section. For highly figured lumber and areas near a knot, some amount of chipping is normal. In this case, moistening the problematic area before planing can sometimes mitigate the issue.

Chipping can also be caused by dirty or dull cutters. If chipping happens while planing straight grain stocks, inspect cutter inserts and remove all resin buildups. Rotate/replace dull cutter inserts when they are dull.



Indentation

This can happen when some foreign object is pressed on the workpiece when it passes through the planer. Remove all resin buildups from the rollers, cutterhead, and table. Also, check the dust collection system and ensure all wood chips generated are effectively removed.

Grooves or ridges along the plane direction

Check the cutter inserts to make sure they are not shifted, chipped, or destroyed.

Fuzzy Grain

This can happen when planing wood with high moisture content or if the cutter is dull. Sometimes, this is unavoidable due to the nature of certain wood types. To mitigate this issue, avoid using wood with high moisture content and use sharp cutters.

Accessories

Oliver Machinery has a collection of accessories for your planer. Please visit our website, OLIVERMACHINERY.NET, to purchase these items.

You may also call **1-800-559-5065** or email PARTS@OLIVERMACHINERY.NET to purchase these items. We are available Monday through Friday, 9 AM - 5 PM Pacific Time.



Using unapproved accessories may cause the machine to malfunction, resulting in serious injury and/or machine damage. Only use accessories recommended for this machine.

Cutter Inserts



Genuine HCX four-sided indexable carbide cutter insert that will fit the cutterhead of Oliver 10045 Planer.

Parts numbers:
Cutter Inserts (Box of 10) - **P-15mm4S**
Torx Screws - **038201-101**

Motor Carbon Brush



Carbon brushes for this planer have a rated life span of 170 hours. Please inspect carbon brushes regularly. Replace them as a pair when they are worn.

Parts number: **430012-000**

Please visit our website at WWW.OLIVERMACHINERY.NET/ACCESSORIES for other recommended accessories.

Maintenance

Routine maintenance keeps your planer in top shape. Please follow the maintenance schedule below and use the maintenance record worksheet in the manual to document all tasks completed.

NOTICE: Maintenance schedule may vary for individual users due to different situations and safety requirements.

 WARNING	Disconnect the machine from the power source before any maintenance work is performed. After servicing the planer, remove all wrenches and tools before restarting the machine. Failure to comply can cause serious injury!
---	--

Maintenance Schedule

Interval	Task
Every day	Remove dust buildups from the planer.
	Inspect the power cord and plug for signs of aging and damage. Replace as needed.
Every week	Inspect cutterhead and rollers. Remove any dust and resin accumulation.
	Inspect/rotate/replace worn cutter inserts.
	Wax planer bed and extension wings.
Every Month	Inspect motor carbon brushes. Replace as a pair when worn. Motor brush life expectancy: 170 Hours
	Inspect the elevation of the extension tables. Adjust as needed.
Every 6 months	Inspect the poly V-belt and replace it if it shows signs of cracking or glazing.

Notice: Motor bearings are permanently sealed and lubricated and do not require lubrication.

Rotate/Replace Cutter Inserts



Cutter inserts are extremely sharp. Protect your hands with thick leather gloves to avoid injuries.

1. **Disconnect the planer from the power source!!**
2. Remove the dust shroud.
3. Remove the cutterhead cover with a 4mm hex wrench.

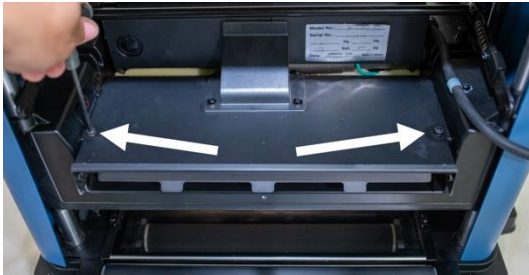

4. Remove dust and resin accumulations on the cutterhead and areas nearby.
5. Rotate cutter inserts 90° clockwise when they get dulled or nicked. Use a permanent marker to mark the new edge to be used.
6. To rotate/replace a cutter insert, remove the Torx screw with a T-25 Torx bit. Turn **COUNTERCLOCKWISE** to loosen the screw.
7. With the cutter insert removed from its seat, thoroughly clean the seat with a vacuum.



IMPORTANT: Obstacles between the insert and its seat will create uneven pressure against the insert. This will impact cut quality and may cause the insert to break.

8. Inspect the Torx screw. Replace any damaged screws. Lubricate screw thread with a thin coat of lightweight machine oil or anti-seize.

IMPORTANT: Do not apply an excessive amount of lubrication, or the Torx screw and the cutter insert will not sit properly.

9. Reinstall the cutter insert with the Torx screw and the marked cutting edge facing out. Secure the cutter insert with 30 lbs.-inch of torque.

IMPORTANT: Do not overtighten the screw, or the inserts may break. Do not use power tools to tighten the Torx screws, as it can strip the screws.

10. Reinstall the cutterhead cover and dust shroud after servicing the cutterhead.

Inspect / Replace Poly V-Belt

1. **Disconnect the planer from the power source!!**
2. The drive belt of the planer is located behind the right panel. To access the drive belt, begin by removing the carriage crank.
3. Loosen four screws that hold the top panel in place.



4. Slightly lift the top panel and remove the right panel.



5. Inspect the drive belt for signs of aging. Replace the belt as needed.
6. To replace the drive belt, remove the old belt from the pulleys by walking it out from the pulleys or simply cutting it off.



7. Install a new belt by gently walking the belt back into the pulleys. A new belt can be very tight, so walk the belt back to the pulleys one groove at a time on each pulley. Refrain from using tools to pry the belt back in place, as it may overstretch the new belt and damage the pulleys.



8. Rotate the pulleys and make sure the drive belt is fully seated into the grooves of the pulleys.
9. Reinstall the side panel and carriage crank after belt maintenance.

Inspect / Replace Motor Carbon Brushes

1. **Disconnect the planer from the power source!!**
2. This planer is equipped with two motor carbon brushes. They are located in the front and back of the carriage.

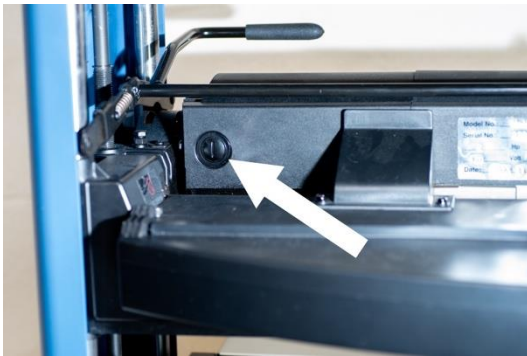

3. To access the motor carbon brushes, unscrew the cover with a flathead screwdriver.



4. Inspect motor carbon brushes. Replace the carbon brushes as a pair when they are significantly worn. The carbon brushes are available on our website (part# 430012-000).

<https://olivermachinery.net/accessories>

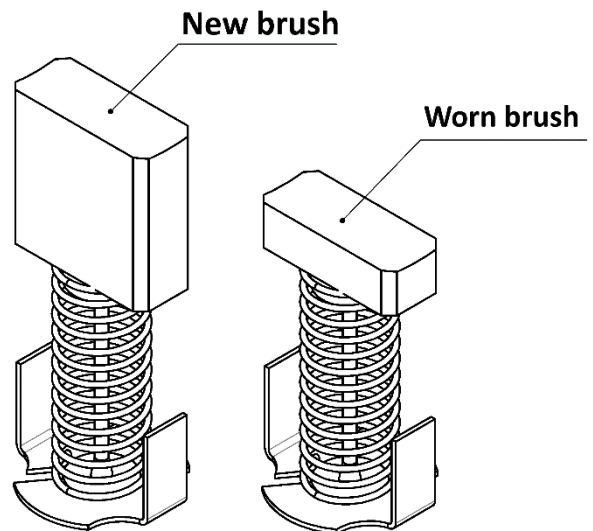

5. Make sure the carbon brushes are properly reinstalled. Use the cover to compress the spring while screwing the cover back onto the carriage.



Inspect / Adjust Extension Wings

The planer's extension wing was adjusted in the factory and should not require further adjustments.

The extension wings were adjusted such that the outside edge of the extension wing is slightly tilted up above the planer bed, and the inside edge is level with the planer bed. This setup can minimize snipes in most use cases.

When planing heavy stock, the weight of the stock may cause the extension wings to dip below the planer bed. If this happens, raise the tip of the extension wing.

If the front-to-end thickness of the planed stock is uneven, the tip of the extension wings may be too high.

To Adjust the Extension Wings

1. **Disconnect the planer from the power source!!**
2. Inspect the extension wing setting. Place two pennies on each end of the planer bed, then use the pennies to support a straight edge. The straight edge needs to be long enough to span across the planer bed and the extension wings.

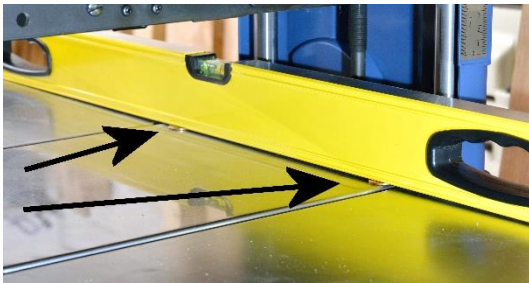

3. With the standard settings, the straight edge should touch the outside edge of the extension wings while sitting on the two pennies.

4. If adjustment is needed, lift the extension wing and locate the stop bolts to set the extension wing's tilt angle.



5. Loosen the jam nuts, then adjust the stop bolts to set the tilt angle of the extension wing.
6. Tighten jam nuts and re-check the extension wings settings.

If the extension wing is not level with the planer bed side-to-side:

1. Lower the extension wings so the extension wing is approximately level with the planer bed.
2. Loosen the extension wing mounting screws and adjust the extension wing so that the extension is coplanar and level with the planer bed. Re-tighten the extension screws afterward.



3. Follow the instructions in the previous section to slightly elevate the tip of the extension wings.

Adjust Cutterhead Height Scale

The cutterhead height scale is pre-calibrated in the factory. It can be re-adjusted to accommodate a different viewing angle or if the pointer is shifted.

1. Prepare a piece of 2x4 with a flat bottom for calibration.
2. Plane the board down to 1-1/4" or 1". Use a caliper to measure the mid-section of the board for thickness.
3. Loosen the screws that hold the pointer in place.



4. Shift the pointer so it is pointing at the exact value of the thickness of the board.
5. Re-tighten the screws.

Adjust Carriage Elevation Chain Tension

Carriage elevation chain tension was set in the factory. It does not require adjustments initially. Over time, the chain may stretch. Tighten the chain if excessive play is felt when adjusting the height of the cutterhead.

1. **Disconnect the planer from the power source!!**
2. Turn the planer sideways to expose the chain, which is located underneath the base of the planer.
3. Loosen the hex cap screw that locks the chain tensioner.

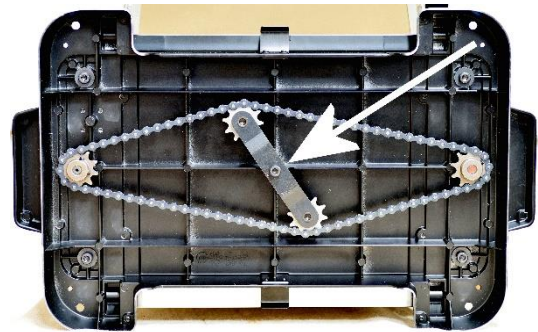

IMPORTANT: Keep the chain on the sprockets while adjusting its tension. If the chain falls off from the sprockets, it can take some time to recalibrate the planer.

4. Rotate the chain tensioning bracket to tighten the chain, then re-tighten the locking cap screw. The chain should deflect by approximately 3/8" when it is compressed between sprockets. The chain is too tight if the carriage crank becomes difficult to turn.
5. Clean and lubricate the chain as needed.

Troubleshooting

Mechanical / Electrical Issues

Problem	Possible Cause	Possible Solution
Machine does not start.	Machine is not connected to a power source.	<ol style="list-style-type: none"> 1. Make sure the machine is plugged in. 2. Check the electrical panel for a tripped circuit breaker or a blown fuse. 3. Ensure all electrical connections have good contacts.
	Low voltage/current.	<ol style="list-style-type: none"> 1. If an extension cord is used, use a shorter/heavier extension cord. 2. Have an electrician to check/repair the power circuit.
	Worn motor brushes.	Replace motor brushes.
	Faulty switch/motor.	Contact customer service for further assistance.
Machine trips thermal protection/circuit breaker or blow fuses.	Machine is undersized for the operation.	Reduce the depth of cut.
	Workpiece moisture level is too high.	Only plane wood with moisture level below 20%.
	Machine is jammed.	Inspect the cutterhead and make sure it is not obstructed by woodchips. Check dust shroud and clear blockages.
	Too much load on a circuit.	Make sure the power circuit is sized for this machine. If the circuit is shared, ensure it is sized to supply power for all items in the circuit.
	Motor issue.	Contact customer service for further assistance.
Machine stalls during operation.	Machine is undersized for the operation.	Reduce the depth of cut.
	Dull cutters.	Rotate/replace cutter inserts.
	Belt slipping.	Clean belt and pulleys. Replace the belt as needed.
	Motor issue.	Contact customer service for further assistance.
Machine stopped during operation.	Overload protection triggered.	Hit the OFF button and allow the machine to cool down for at least 3 minutes, then press the overload protection reset button. Reduce the depth of cut before resuming work.
Digital readout is not functional.	Dead battery.	Replace the battery (AAA type).
	Frozen display	Remove batteries. Wait for 1 minute and reinstall the batteries.

Problem	Possible Cause	Possible Solution
Workpiece does not feed smoothly.	Dirty planer bed/rollers.	Clean table and rollers. Apply paste wax on the planer bed and extension wings to reduce drag. Do not use silicone lubrication.
	Belt slipping.	Clean belt and pulleys. Replace the belt as needed.
Machine vibrates excessively or makes unexpected noise.	Damaged cutter inserts.	Replace cutter inserts.
	Machine stands on an uneven surface.	Reposition on a flat, level surface.
	V-belt worn, slipping, or hitting belt cover.	Clean belt and pulleys. Replace the V-belt if it shows signs of aging.
	Loose components.	Tighten the fasteners of the component.
Board thickness does not match the scale's measurement.	Cutterhead height scale is mispositioned.	Adjust scale.
Unable to turn carriage crank.	Carriage is locked.	Lift the carriage lock lever to unlock the carriage.
	Carriage is stopped by depth stop.	Adjust the depth stop's minimum height setting. Minimum cutterhead height is 5/32".

Finish Quality Issues

Problem	Possible Cause	Possible Solution
Workpiece came out twisted.	Workpiece is twisted before the cut.	Planer is not the tool to flatten a twisted workpiece. Flatten one side with a jointer before proceeding with a planer.
Excessive snipe.	Extension wing slope down.	Adjust extension wing elevation.
	Long workpiece is not supported properly.	Use auxiliary rollers to support the long workpiece.
	A small amount of sniping can happen sometimes.	Add an extra 6" length on a workpiece for planing, and then trim off the ends.
End of workpiece chipping.	Aggressive depth of cut for the wood type.	Reduce the depth of cut.
	Planing end grain.	Do not plane end grain. Use a drum sander instead.
Chipping in workpiece surface.	Damaged cutter.	Rotate/replace cutter insert.
	Planing against/across grain or knots.	Avoid planing workpieces with knots. Plane with grain whenever possible. Moisten problematic areas before planing.
	Too much material was removed in one pass.	Reduce the depth of cut.
Indentation in workpiece surface.	Dirty rollers.	Remove all buildups on infeed, outfeed, and table rollers.
	Inefficient chip removal.	Check the dust collection system for suction.
Fuzzy-looking finish.	Wood moisture content is too high.	Only process wood with less than 20% moisture content.
	Dull cutter.	Rotate/replace cutter insert.
	Some wood types tend to have fuzzy grain.	Adjust the depth of cut. Use sharp cutters.
Glossy-looking finish.	Dull cutter.	Rotate/replace cutter insert.
	Cutting depth too shallow.	Increase depth of cut.
Long lines or ridges run along the length of the board.	Chipped or incorrectly installed cutter.	Rotate/replace cutter insert.

Wiring Diagram

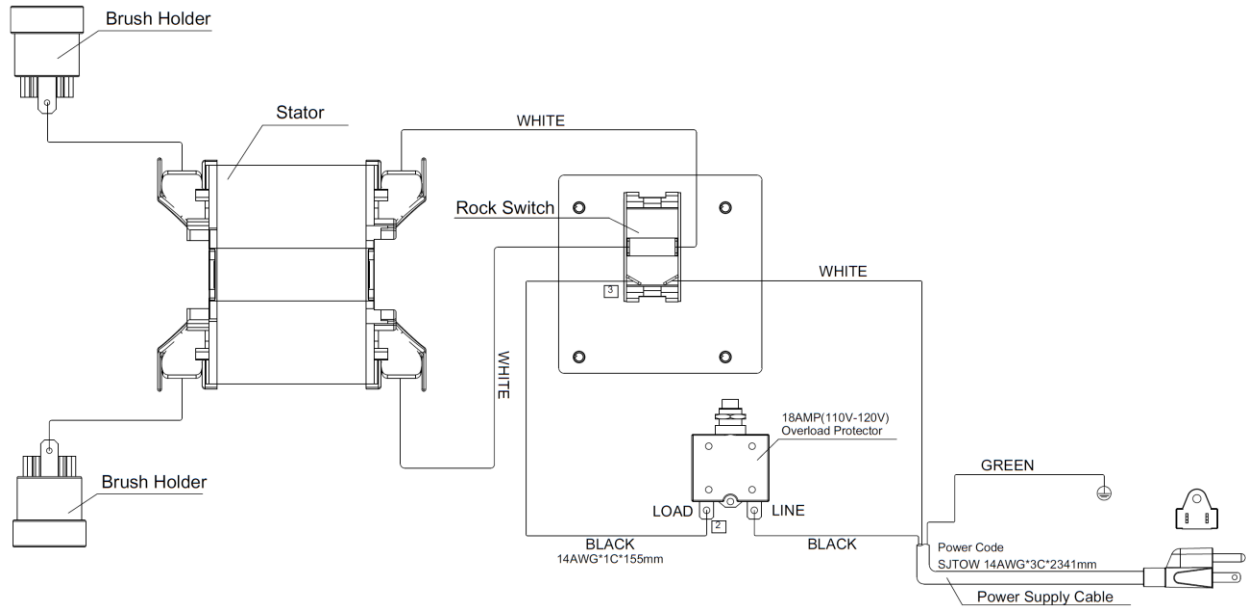

Parts List

Carriage and Cutterhead Assembly

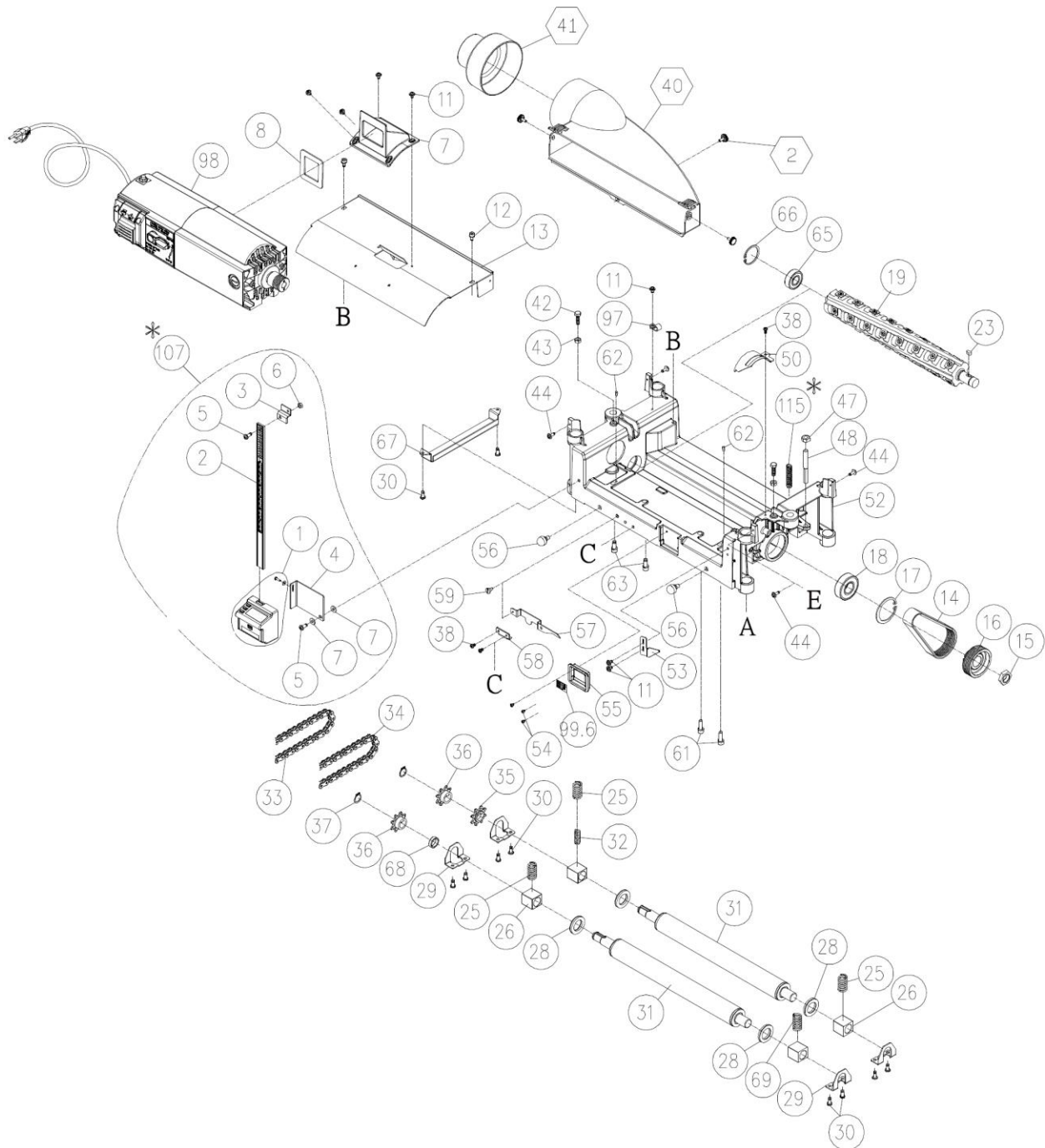

Motor Assembly

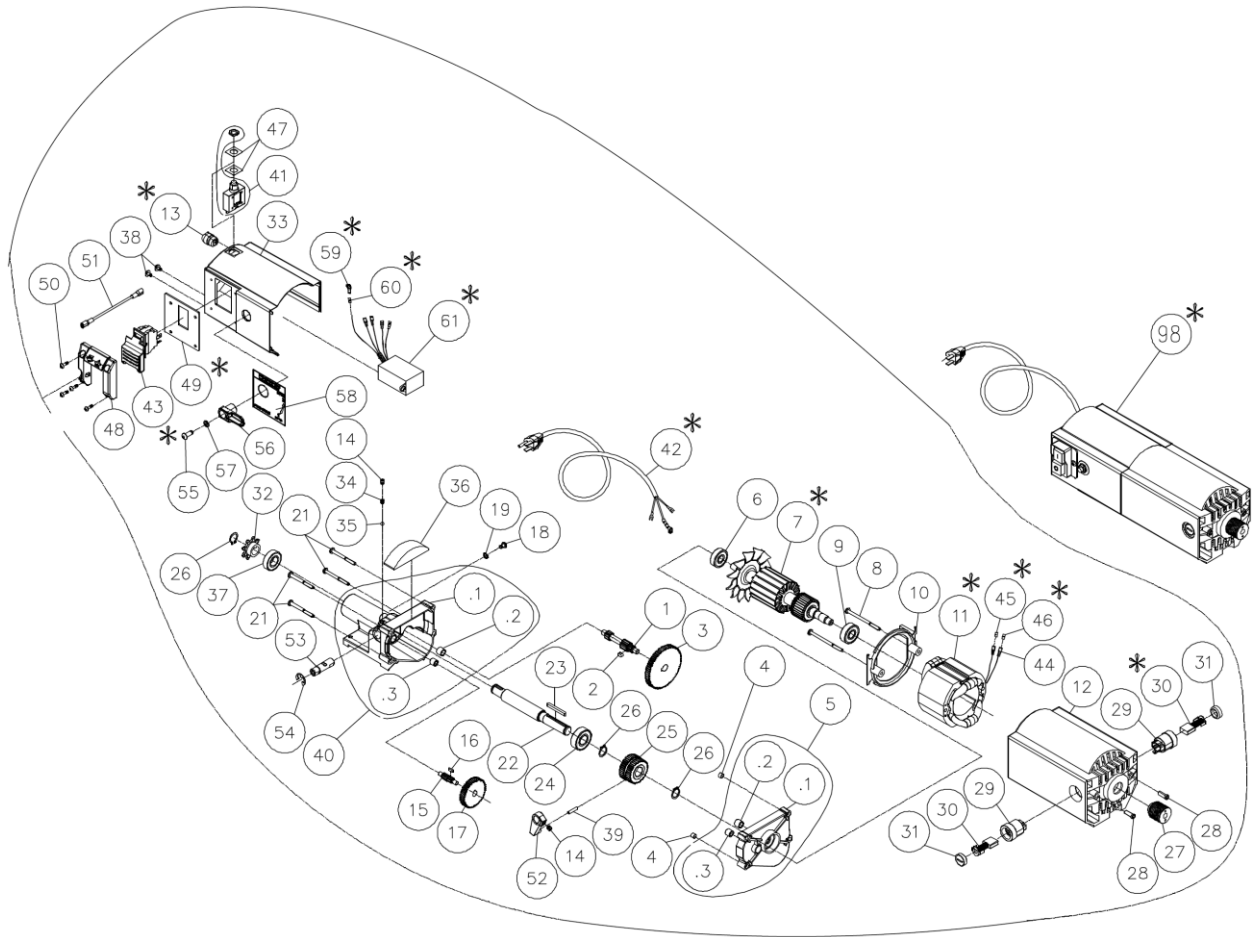

Body and Base Assembly

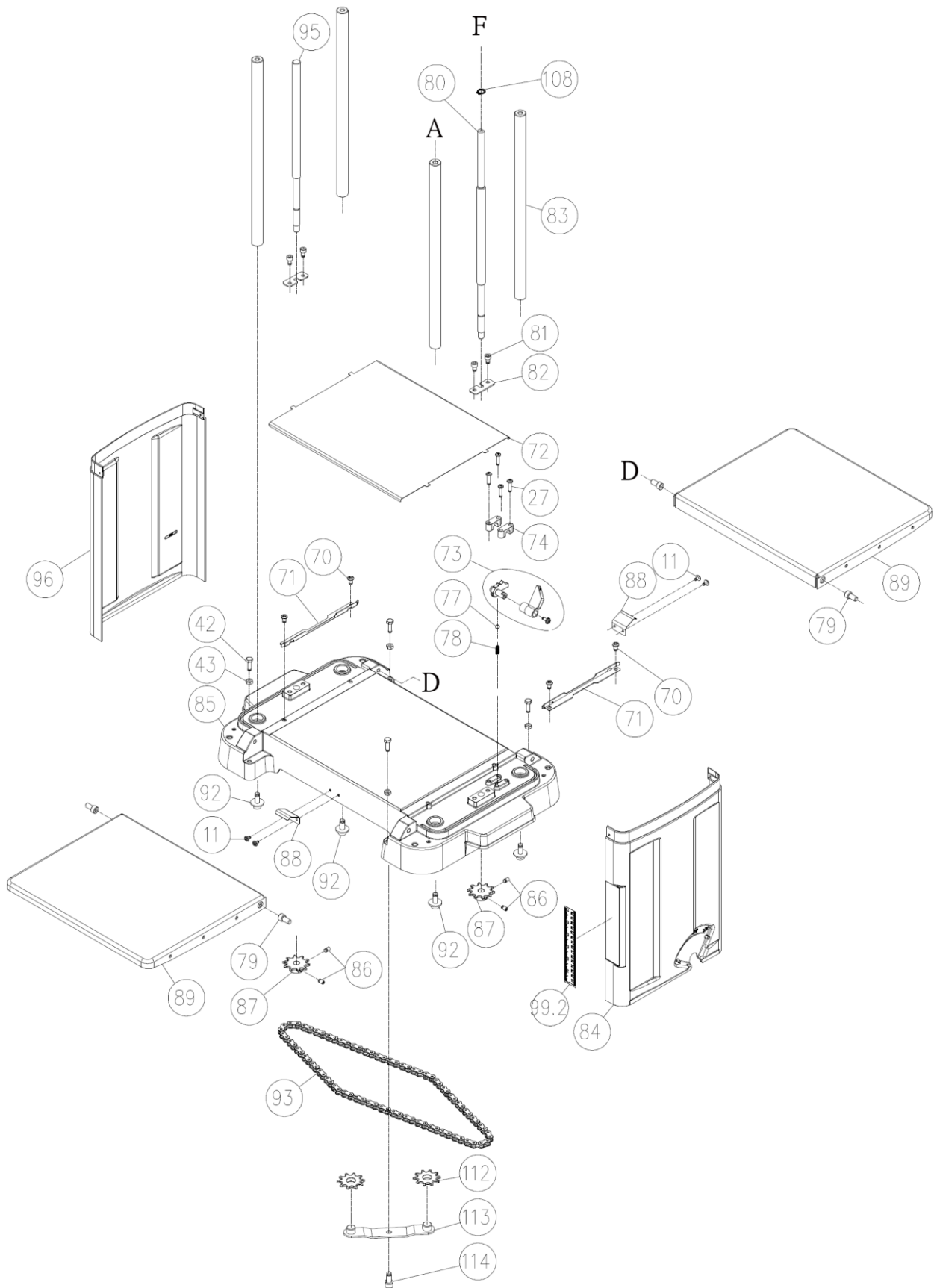

Top and Carriage Lock Assembly

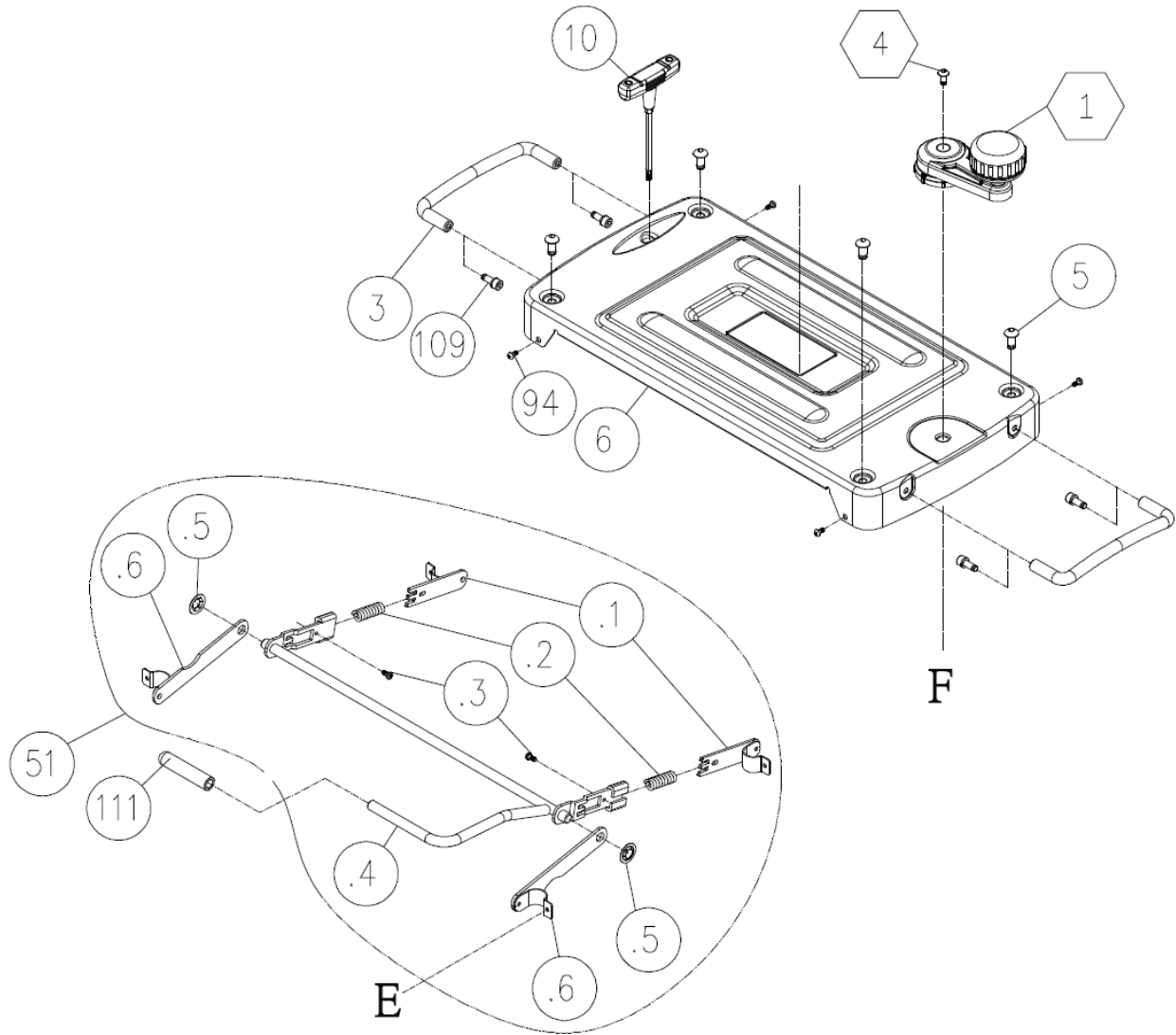

Key	Part Number	Descriptions	QTY
1	924830-001	Handle Assembly Inch	1
2	230437-615	Knob	3
3	381511-904	Handle	2
4	000801-102	Round Head Socket Screw M6*1.0P*12	1
5	000802-101	Round Head Socket Screw M8*1.25P*16	4
6	175219-000	Upper Cover	1
7	251400-615	Vent Lid	1
8	200111-615	Foam 2mm	1
10	925317-001	T30 Star Wrench T25	1
11	001601-801	Round Head Phillip Screw + Washer M4*0.7P*8/4*10*0.8t	11
12	001801-101	T Type Screw + Lock Washer M5*0.8P*10/5.1*9.3	2
13	925310-001	Deflector Assy	1
14	014302-000	Drive Belt 135J-6	1
15	008036-200	Hex Nut M16*1.5P(23B*8H)	1
16	090394-000	Drive Pully	1
17	010107-000	R Ring RTW-47	1
18	030208-001	Ball Bearing 6204	1
19	925293-001	Helical Cutterhead Assembly	1
19.1	925318-001	Helical Cutterhead Assembly 3 Slots 36 inserts	1
19.2	850925-001	Hardware Bag	1
19.2.1	924669-001	Insert Pack of 5	1
19.2.2	850920-001	Trox Screw Bag Pack of 5	1
23	012003-002	Key 5*5*10	1
25	280035-901	Spring	3
26	130088-000	Bearing Block	4
27	000303-707	Round Head Phillip Screw M5*0.8P*20	4
28	660010-000	Dust Proof Plate	4
29	175164-901	Mounting Plate	4
30	000303-804	Round Head Phillip Screw M5*0.8P*12	10
31	340098-000	Roller	2
32	280036-901	Spring	1
33	016204-000	Chain #410*26P	1
34	016218-000	Chain #410*27P	1
35	150030-000	Sprocket	1
36	150004-000	Sprocket	2
37	010006-000	S Ring STW-15	2
38	000302-102	Round Head Phillip Screw M4*0.7P*8	3
40	250114-615	Dust Port	1

Key	Part Number	Descriptions	QTY
41	250133-615	Connector	1
42	000002-111	Hex Screw M6*1.0P*20	6
43	008005-100	Hex Nut M6*1.0P(10B*5H)	6
44	002401-101	Round Head Phillip Nylock Screw + Washer M4*0.7P*12/4*10*0.8t	4
47	008006-100	Hex Nut M8*1.25P(13B*6.5H)	1
48	360309-901	Shaft	1
50	175226-901	Pulley Cover	1
51	924820-001	Rod Linkage Assembly	1
51.1	921937-001	Rod Assembly	2
51.2	280039-901	Spring	2
51.3	000302-102	Round Head Phillip Screw M4*0.7P*8	2
51.4	924819-001	Handle Assembly	1
51.5	010304-000	Spn Ring SPN-10	2
51.6	921938-001	Rod Linkage Assembly	2
52	090393-147	Carriage	1
53	175225-156	Scale Pointer	1
54	000301-101	Round Head Phillip Screw M3*0.5P*6	3
55	251401-615	Scale Plate	1
56	340009-000	Buffer Pad	2
57	170314-458	Material Remove Gauge Pointer	1
58	170313-901	Contact Plate	1
59	290012-901	Shoulder Screw	1
61	230238-905	Self Tap Screw W Lock Washer	2
62	360297-000	Pin	2
63	001802-102	Cap Screw + Lock Washer M6*1.0P*20/6.5*10.5	2
65	030206-001	Ball Bearing 6202	1
66	010103-000	R Ring RTW-35	1
67	175232-000	Chain Cover	1
68	160031-000	Spacer	1
69	280037-000	Spring	1
70	000304-102	Round Head Phillip Screw M6*1.0P*10	4
71	175220-901	Guide Rail	2
72	175221-000	Wear Plate	1
73	924828-001	Depth Stop Assembly	1
74	130392-903	Bracket	2
77	017002-000	Steel Ball Ø6	1
78	280052-000	Spring	1
79	000104-107	Cap Screw M8*1.25P*15	4
80	361376-902	Lead Screw	1
81	000103-102	Cap Screw M6*1.0P*10	4

Key	Part Number	Descriptions	QTY
82	270005-000	Fix Plate	2
83	360307-000	Column	4
84	251402-000	Right Side Cover	1
85	090353-000	Base	1
86	001902-101	Set Nylock Screw M6*1.0P*10	4
87	150005-000	Sprocket	2
88	270007-901	Clip	2
89	925285-001	Table Assy	2
92	001701-101	Cap Screw + Washer M8*1.25P*20/8*23*2.0t	4
93	016211-000	Chain #410*82P	1
94	001201-804	Round Head Self Screw M4*1.41P*8	4
95	360306-902	Lead Screw	1
96	251403-000	Left Side Cover	1
97	021102-000	Wire Fixing Buckle ACC-2.5	1
98	910153-001	Motor Assy. 110V	1
98.29	430003-000	Brush Holder	2
98.30	430012-000	Brush 110V	2
98.31	430006-000	Brush Cap	2
98.43	830014-001	Switch Assembly J-9301A	1
98.49	175223-904	Switch Plate	1
99.2	575140-000	Scale	1
99.6	575545-000	Depth Scale 3/32"	1
107	925047-001	Wixey Digital Readout Assembly Wixey WR510 w/Back Light	1
107.1	491208-000	Digital Readout	1
107.2	950827-001	Magnetic Ruler Assy	1
107.3	174979-904	Upper Mounting Bracket	1
107.4	174980-904	Lower Mounting Bracket	1
107.5	000303-804	Round Head Phillip Screw	2
107.6	008004-100	Hex Nut	1
107.7	006001-010	Flat Washer	2
108	010002-000	S Ring STW-11	1
109	001802-101	Cap Screw + Lock Washer M6*1.0P*16/6.5*10.5	4
111	251437-615	Lock Handle	1
112	150006-000	Sprocket	2
113	170310-901	Plate	1
114	001803-102	Cap Screw + Lock Washer M8*1.25P*20/8.2*13.7	1
115	280012-000	Spring	1

Spare Parts

Part Number	Descriptions	QTY
P-15mm4S	Box of 10 - 15mm x 15mm x 2.5t - 4-Sided Carbide Inserts	10
038201-101	Torx Screw for HCX Cutterhead	10
430012-000	Carbon Brush Set (Set of 2)	1

Maintenance Record

Date	Task	Operator

Notes

Warranty and Service

Oliver Machinery makes every effort to assure that its equipment meets the highest possible standards of quality and durability. All products sold by Oliver Machinery are warranted to the original customer to be free from defects for a period of two (2) years on all parts excluding electronics and motors which are warranted for one (1) year from the date of shipment. Oliver Machinery's obligation under this warranty shall be exclusively limited to repairing or replacing products or parts or components, at its sole option, determined by Oliver Machinery to be defective. Oliver Machinery shall not be required to provide other form of indemnity or compensation including but not limited to compensatory damages.

This warranty does not apply to defects due to direct or indirect misuse, abuse, negligence, accidents, unauthorized repairs, alternation outside our facilities, lack of maintenance, acts of nature, or items that would normally be consumed or require replacement due to normal wear and tear.

OTHER TERMS

To obtain and exercise the warranty right, please call 800-559-5065 or fill out warranty request form online at www.olivermachinery.net.

Warranty parts are shipped via Parcel or Ground. Additional charges will occur and charge to customers if express shipping is required.

DISCLAIMER

Under no circumstances shall Oliver Machinery be liable for death, personal or property injury, or damages arising from the use of its products.

Oliver Machinery reserves the right to make changes without prior notice to its products to improve function or performance or design.

FOR MORE INFORMATION

If you need assistance or have questions beyond what is covered in the scope of this warranty information, please call 800-559-5065 or email us at info@olivermachinery.net.

Appendix

US Standard – Metric Conversion Chart

Fractions	Decimal In.	Millimeters
1/64	.0156	.396
1/32	.0312	.793
3/64	.0469	1.190
1/16	.0625	1.587
5/64	.0781	1.984
3/32	.0937	2.381
7/64	.1094	2.778
1/8	.125	3.175
9/64	.1406	3.571
5/32	.1562	3.968
11/64	.1719	4.365
3/16	.1875	4.762
13/64	.2031	5.159
7/32	.2187	5.556
15/64	.2344	5.953
1/4	.25	6.350
17/64	.2656	6.746
9/32	.2812	7.143
19/64	.2969	7.540
5/16	.3125	7.937
21/64	.3281	8.334
11/32	.3437	8.731
23/64	.3594	9.128
3/8	.375	9.525
25/64	.3906	9.921
13/32	.4062	10.318
27/64	.4219	10.715
7/16	.4375	11.112
29/64	.4531	11.509
15/32	.4687	11.906
31/64	.4844	12.303
1/2	.5	12.700

Fractions	Decimals In.	Millimeters
33/64	.5156	13.096
17/32	.5312	13.493
35/64	.5469	13.890
9/16	.5625	14.287
37/64	.5781	14.684
19/32	.5937	15.081
39/64	.6094	15.478
5/8	.625	15.875
41/64	.6406	16.271
21/32	.6562	16.668
43/64	.6719	17.065
11/16	.6875	17.462
45/64	.7031	17.859
23/32	.7187	18.256
47/64	.7344	18.653
3/4	.75	19.050
49/64	.7656	19.446
25/32	.7812	19.843
51/64	.7969	20.240
13/16	.8125	20.637
53/64	.8281	21.034
27/32	.8437	21.431
55/64	.8594	21.828
7/8	.875	22.225
57/64	.8906	22.621
29/32	.9062	23.018
59/64	.9219	23.415
15/16	.9375	23.812
61/64	.9531	24.209
31/32	.9687	24.606
63/64	.9844	25.003
1.0	1.	25.400



Oliver Machinery is always adding new Industrial Woodworking products to the line.

For complete, up-to-date product information, visit us online at:

WWW.OLIVERMACHINERY.NET

or call toll-free 1-800-559-5065

**** SAVE THIS MANUAL FOR FUTURE REFERENCE. ****