

Table Saw

Model 10040 Series

Owner's Manual

For Models Manufactured Since 01/2017



Oliver Machinery
1-800-559-5065
921 Thomas Ave SW,
Renton, WA 98057

info@olivermachinery.net
WWW.OLIVERMACHINERY.NET

Stock Number: 10040.101
10040.102
Manual Version: 2.0.0



READ AND UNDERSTAND ALL INSTRUCTIONS IN THIS MANUAL BEFORE ATTEMPTING TO ASSEMBLE OR OPERATE THE MACHINE.

FOLLOW THE INSTRUCTIONS AND THINK SAFETY!

THE OWNER OF THIS MACHINE IS SOLELY RESPONSIBLE FOR THE SAFETY OF ANYONE USING THIS MACHINE. SUCH RESPONSIBILITY INCLUDES BUT NOT LIMITED TO:

- **PROPER ASSEMBLY, OPERATION, INSPECTION, MAINTENANCE, AND RELOCATION OF THE MACHINE.**
- **PROPER TRAINING FOR THE OPERATORS AND ENSURES THIS MANUAL IS AVAILABLE AT ALL TIMES.**
- **USAGE AUTHORIZATION.**
- **USAGE OF SAFETY AND PROTECTION DEVICES.**

OLIVER MACHINERY DISCLAIMS ANY LIABILITY FOR MACHINES THAT HAVE BEEN ALTERED OR ABUSED. OLIVER MACHINERY RESERVES THE RIGHT TO EFFECT AT ANY TIME, WITHOUT PRIOR NOTICE, THOSE ALTERATIONS TO PARTS, FITTINGS, AND ACCESSORY EQUIPMENT WHICH THEY MAY DEEM NECESSARY FOR ANY REASON WHATSOEVER.

**** SAVE THIS MANUAL FOR FUTURE REFERENCE. ****

PROP 65 NOTICE

WARNING: Drilling, sawing, sanding, or machining wood products can expose you to wood dust, and/or other chemicals that are known to the State of California to cause cancer, birth defects, or other reproductive harm.

Some examples of these chemicals are:

- Lead from lead-based paints.
- Crystalline silica from bricks, cement, and other masonry products.
- Arsenic and chromium from chemically treated lumber.

Avoid inhaling wood dust and other harmful chemicals. Use a dust mask and/or other safety devices for personal protection.

For more information go to <http://www.P65Warnings.ca.gov/wood>

Table of Contents

Introduction	5	Cutting with Dado Set.....	42
Specifications	6	After Using the Table Saw.....	43
Identification	10	Changing Saw Blade.....	44
Safety	12	Calibrations and Adjustments	45
General Safety Guidelines.....	13	Blade to Miter Slot Alignment.....	45
Electricals	14	Fence Lock Tightness	46
Minimum Circuit Size Required for Model 10040 Table Saw	14	Fence to Miter Slot Alignment	46
Grounding.....	14	Fence Squareness Adjustment	47
Electrical Wiring	15	Fence Height Adjustment.....	47
Setup	16	Fence Scale Adjustment.....	48
Shop Preparation.....	16	Miter Gauge Angle Indicator Adjustment ..	48
Receiving.....	17	Miter Gauge Positive Stop Adjustment.....	49
Inventory	19	Blade Tilt Angle Pointer Adjustment	49
Cleaning	21	Blade Angle Positive Stops Adjustments.....	50
Moving / Bolting Down the Table Saw.....	21	Spreader/Riving Knife Alignment Adjustment.....	51
Essential Checks Before Assembly	22	Maintenance	52
Assembly	26	Cleaning and Lubrication	53
Extension Wing Installation.....	26	Belt Tension Adjustment.....	54
Table Saw Rails Installation.....	27	Belt Replacement	55
Right Extension Table Installation (For Stock #10040.102 Only).....	28	Troubleshooting	56
Table Insert Setup	29	Wiring Diagrams	60
Fence Setup.....	31	Parts List	61
Push Stick Storage.....	32	Table and Cabinet.....	61
Dust Collection	33	Motor and Trunnion Assembly.....	62
Accessories	34	Rip Fence Assembly	63
Operation	35	Right Table Assembly (Stock #10040.102) ..	64
Safety Guidelines for Preparing for a Cut ..	35	Blade Guard and Miter Gauge.....	65
Safety Guidelines for Using the Table Saw ..	38	Maintenance Record	72
Making a Rip Cut	39	Notes	73
Making a Cross Cut	40	Warranty and Service	74
Notes for Making a Miter Cut.....	41		
Notes for Making a Bevel Cut.....	41		

Introduction

Thank you for choosing Oliver! This manual contains important information on how to safely set up, operate, and maintain this machine. Please take the time to read through this manual, and make sure you understand all instructions.

While this manual may provide tips on optimizing the result of your workpiece, the manual is not intended as a substitute for formal woodworking training. If you need to know how to safely complete a woodworking task, please consult knowledgeable and qualified sources before proceeding further.

We made every effort to keep this manual up-to-date. Instructions, specifications, drawings, and photographs in this manual should match the machine delivered. If you find any differences or anything that seems confusing in this manual, please check our website for an updated version:

WWW.OLIVERMACHINERY.NET/MANUALS

Alternatively, you can contact our technical support for help:

1-800-559-5065

Before calling, please note down the manufacture date and the serial number of the machine. You can find the information on a nameplate located on the left side of the machine cabinet, below the motor cover. This information is needed to provide proper technical support, and to determine if an updated manual is available for your machine.

Please let us know how well this manual serves you. If you have any suggestions, please call the number above or email us at:

info@olivermachinery.net

We love to hear from our customers and make improvements.

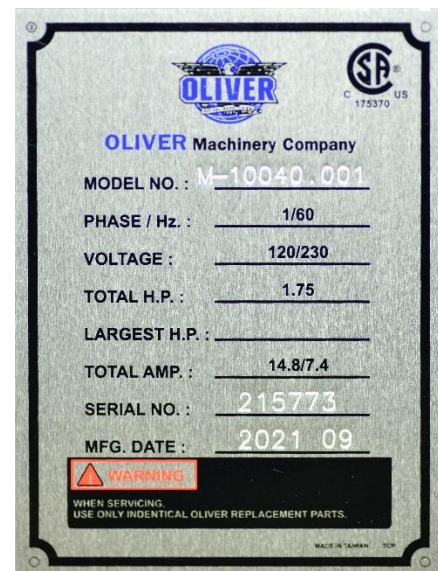

Specifications

Quick View

Model	10040 Table Saw	
Stock Number	10040.101	10040.102
Rail Length	36"	52"
Power Requirement	115V / 230V, 1Ph, 60Hz	
Motor	TEFC 1.75HP, 115V / 230V, 1Ph	
Dimensions	67"(L) x 31-1/2"(D) x 42"(H)	83"(L) x 31-1/2"(D) x 42"(H)
Footprint	19-1/4"(L) x 18-3/4"(D)	64"(L) x 28"(D)
Fully Assembled Weight	279 lbs.	304 lbs.
Warranty	1 Year (Motor and electronics) 2 Years (All other parts)	

Product Dimensions

Stock Number	10040.101	10040.102
Fully Assembled Dimensions	67"(L) x 31-1/2"(D) x 42"(H)	83"(L) x 31-1/2"(D) x 42"(H)
Footprint	19-1/4" (L) x 18-3/4"(D)	64" (L) x 28"(D)
Fully Assembled Weight	279 lbs.	304 lbs.

Shipment Info

Stock Number	10040.101	10040.102
Table Saw		
Packaging	Wood Crate	
Dimensions	40-1/2"(L) x 30"(D) x 46"(H)	
Weight	324 lbs.	
Rails		
Packaging	Cardboard Box	
Dimensions	68"(L) x 4-1/2"(D) x 4-1/2"(H)	85"(L) x 4-1/2"(D) x 4-1/2"(H)
Weight	14lbs	18lbs
Right Extension Table		
Packaging	Cardboard Box	
Dimensions	N/A	34"(L) x 29"(W) x 3-1/4"(H)
Weight	N/A	25lbs.
Approx. Setup Time	120 Minutes	
Must Ship Upright	YES	
Stackable	NO – The table saw wood crate is not stackable.	

Electricals

Power Requirement	115V / 230V, 1Ph, 60Hz
Prewired Voltage	115V
Full Load Current Rating	14.8A @ 115V 7.4A @ 230V
Recommended circuit size	20A @ 115V 15A @ 230V
Power Switch Type	Lockable Magnetic Paddle Switch
Connection Type	NEMA 5-15 Plug with 6' 14AWG Cord

Saw Details

Table Saw Type	Cabinet
Arbor Size	5/8"
Max. Blade Diameter	10"
Max. Dado Blade Diameter	8"
Max. Dado Blade Width	3/4"
Max. Blade Tilt	45° to the left
Max. Depth of Cut at 90°	3-1/8"
Max. Depth of Cut at 45°	2-1/4"
Max. Rip Right of Blade	36" (Stock #10040.101) 52" (Stock #10040.102)
Max. Rip Left of Blade	12"
Living Knife/Spreader Thickness	11/128"
Required Blade Kerf Thickness	> 1/8"
Arbor Speed	4000 RPM
Max. Allowable Arbor Runout	0.001"

Fence

Stock Number	10040.101	10040.102
Fence Rail Length	36"	52"
Fence Rail Material	Aluminum Extrusion (Front Rail) Steel (Rear Rail)	
Fence Type	Camlock T-Shape Fence	
Fence Dimensions	33-1/2"(L) x 3-1/8"(W) x 2-9/16"(H)	
Fence Face Material	Aluminum Extrusion	
Fence Body Material	Steel	

Table

Material	Precision Ground Cast Iron
Main Table Dimensions	20"(L) x 27"(D)
Cast Iron Extension Wing Dimensions	12"(L) x 27"(D)
Extension Table Dimensions	32"(L) x 27"(D)
Overall Table Size	44" (L) x 27"(D) (Stock #10040.101) 76" (L) x 27"(D) (Stock #10040.102)
Table Height from Floor	34-1/2"
Main Table Flatness Tolerance	0.016"
Overall Table Flatness Tolerance	0.025"
Distance from Front Edge to Blade	8-3/4" (at max blade height)
Distance from Rear Edge to Blade	8-3/4" (at max blade height)
Miter Slot Type	T-Slot (Standard Size)
Miter Slot Size (W x H)	3/4" x 3/8"
Blade Alignment /w Miter Slot	0.008"
Tabel Inserts Provided	Zero clearance insert (1) Zero clearance dado insert (1)

Included Blade Information

Type	General-purpose 40T thin kerf blade
Size	10"
Kerf	1/8"
Blade Plate Thickness	5/64"

Miter Gauge

Angle Range	-60° to 60°, with positive stops at -45°, 0°, 45°
Miter Bar Length	18"
Miter Plate Width	6-7/8"

Motor

Motor Type	TEFC
Horsepower	1.75HP
Power Requirement	115V / 230V, 1Ph, 60Hz
Full Load Current Rating	14.8A @ 115V 7.4A @ 230V
Speed	3450 RPM
Power Transfer Mechanism	Poly V-Belt
Bearing type	Permanently Sealed Ball Bearing

Cabinet

Type	Steel cabinet with built-in storage for accessories.
Mobility	Built-in fixed casters with locks

Safety

Blade Guard	Quick-release blade guard.
Riving Knife	Quick-release riving knife.
Number of Dust Ports	1
Dust Port Size	4"
Minimum CFM Required	500 CFM
Sound Rating	85 dB at 3' distance with blade lowered below the table.

Others

Serial Number Location	On the left side of the cabinet.
Certification	CSA 175370
Country of Origin	Taiwan

Identification

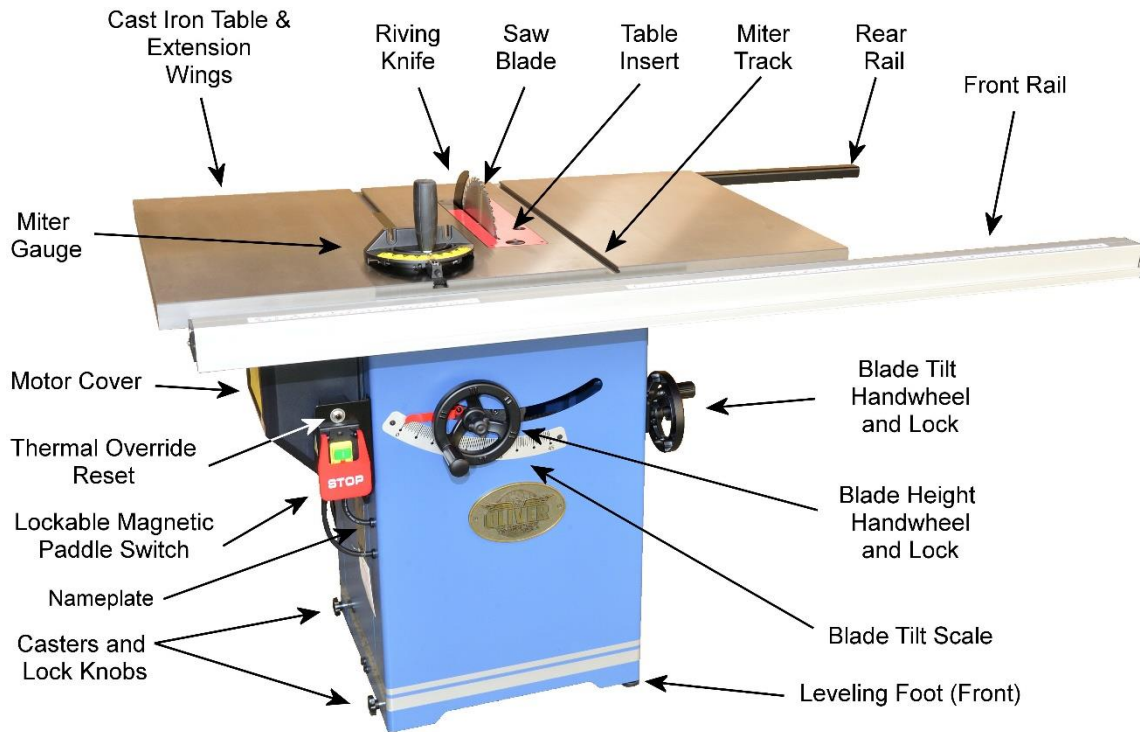

10040.101 with Miter Gauge and Riving Knife Setup

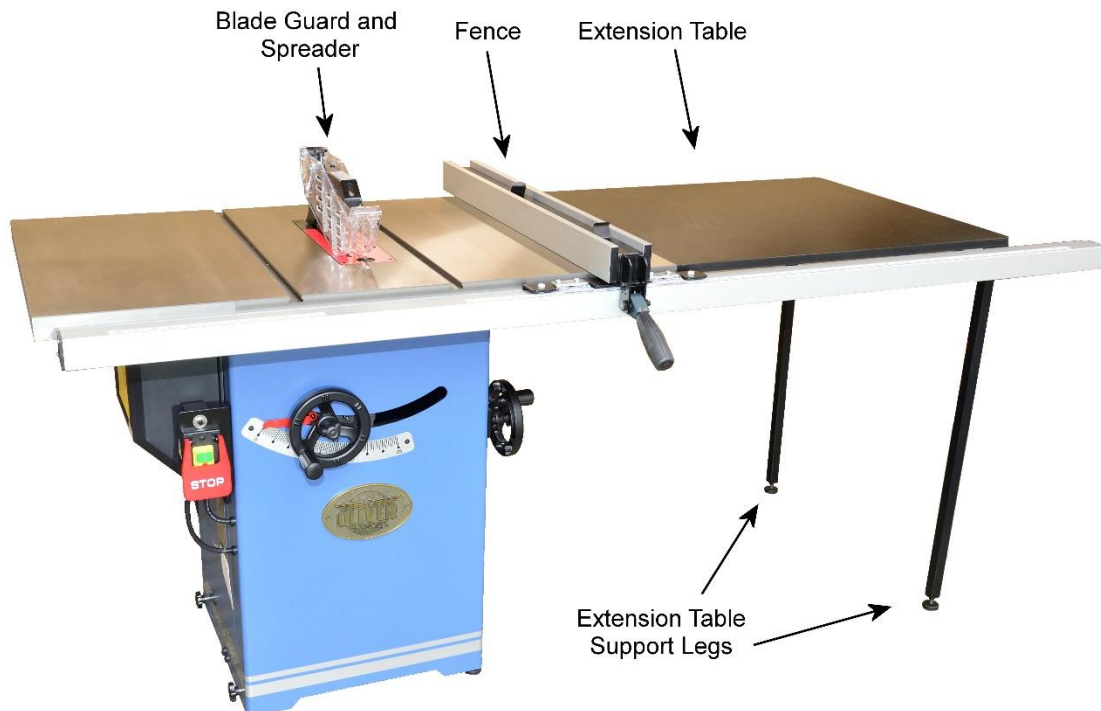

10040.102 with Rip Fence and Blade Guard Setup

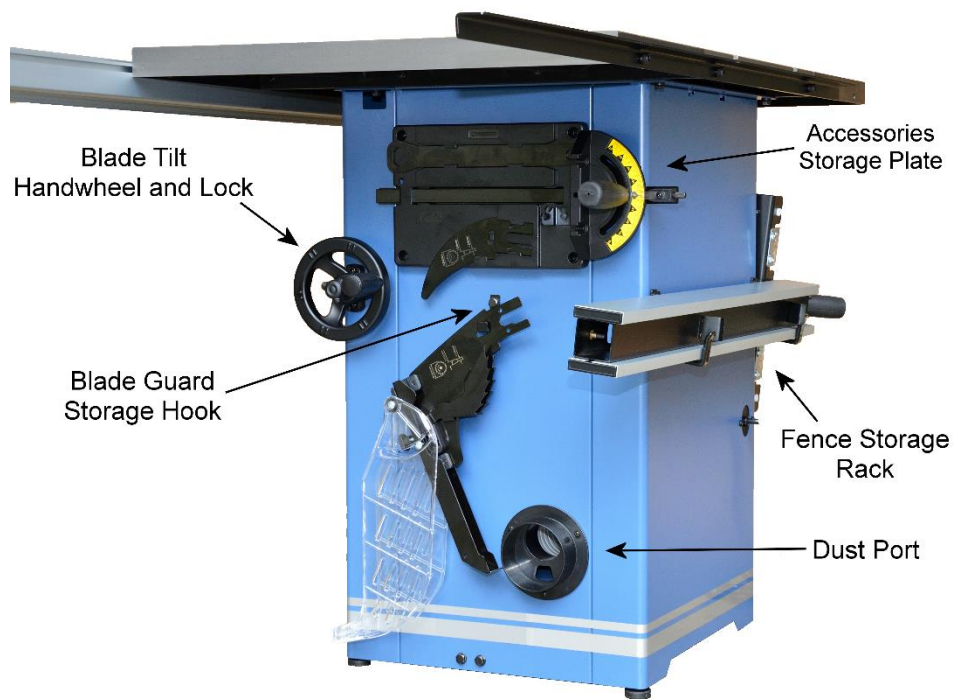





Table Saw Cabinet Rear View

Safety

Oliver Machinery has made every attempt to provide a safe, reliable, easy-to-use piece of machinery. Safety, however, is ultimately depending on the individual machine operator. **Please become familiar with the following safety labels that are used throughout this manual.**

 DANGER	This indicates an imminently hazardous situation which, if not avoided, WILL cause death or serious injury.
 WARNING	This means if the warning is not taken seriously, it CAN cause death or serious injury.
 CAUTION	This means if the precaution is not taken, it MAY cause minor or moderate injury.
IMPORTANT	This is a tip for properly operating the machine to avoid machine damage.



BEFORE OPERATING THIS TABLE SAW, PLEASE READ AND UNDERSTAND THE SAFETY GUIDELINES IN THIS MANUAL AND EXERCISE ALL SAFETY PRECAUTIONS. WHEN IN DOUBT, PLEASE CONSULT ACCREDITED TRAINING RESOURCES OR CONTACT OLIVER MACHINERY FOR HELP. FAILURE TO FOLLOW THE SAFETY GUIDELINES CAN RESULT IN SERIOUS INJURIES OR DEATH.

General Safety Guidelines

1. **FAMILIARIZE** yourself with all safety instructions found in this manual. Know the limitations and hazards associated with this machine. Do not operate/service this machine until you are properly trained.
2. **ELECTRICAL GROUNDING**, when done properly, reduce the risk of electrocution, shocks, and fire. Make certain that the machine frame is electrically grounded and that a ground lead is included in the incoming electrical service. In cases where a cord and a plug are used, make certain that the grounding plug connects to a suitable ground. Follow the grounding procedure indicated in the electrical code of your area.
3. **DISCONNECT** the machine from power before performing any service, maintenance, adjustments, or when changing cutters. A machine under repair should be RED TAGGED to show it should not be used until the maintenance is complete.
4. **GUARDS**: Keep machine guards in place for all applicable operations. If any guards are removed for maintenance, DO NOT OPERATE the machine until all guards are reinstalled. Check clearance between the guards and the cutter before starting the machine.
5. **WORKPLACE SAFETY**: Keep the floor around the machine clean. Scrap material, sawdust, oil, and other liquids increase the risk of tripping or slipping. Be sure to clean up the table before starting the machine. Make certain the work area is well lighted and that a proper exhaust system is used to minimize dust. Use anti-skid floor strips on the floor area where the operator normally stands and mark off the machine work area. Provide adequate workspace around the machine.
6. **ACCESS CONTROL** should be enforced so only trained personnel can access the work area and operate the machine. Make use of the childproof safety feature of the power switch when available.
7. **NEVER STAND ON THE MACHINE**. This prevents injuries from tipping-related accidents and accidental contact with cutters.
8. **REPLACEMENT PARTS**: Use only genuine Oliver Machinery replacement parts and accessories recommended for this machine. Generic parts made by other manufacturers may create a safety hazard and WILL void the factory warranty and other guarantees.
9. **ADDITIONAL SAFETY INFORMATION**:
 - National Safety Council – *Accident Prevention Manual for Business and Industry*: <https://shop.nsc.org/apm-admin-program-14ed>
 - ANSI O1.1: <https://webstore.ansi.org/standards/wmma/ansio12013>
 - OSHA 1910.213: <https://www.osha.gov/laws-regs/regulations/standardnumber/1910/1910.213>

*** ATTENTION ***

Table saw specific safety guidelines are located in section “Operation” (page 35). Familiarize yourself with all safety guidelines before using this saw!

Electricals

	WARNING	Faulty electrical work can cause electrocution and is a fire hazard.
		All electrical work must be completed by a licensed electrician and must meet the local electrical code in your area or the warranty is void.

Minimum Circuit Size Required for Model 10040 Table Saw

Stock Number	Voltage	Minimum Circuit Size Required
10040.101 & 10040.102	115V	20A
	230V	15A

Please ensure the electrical circuit for this machine meets the minimum circuit size requirement. The minimum circuit size requirement applies to a dedicated circuit that provides power to one 10040 Table Saw. If more machines are sharing the same circuit, consult a licensed electrician to ensure the designated circuit is properly sized for safe operation.

If a circuit is available but does not meet the minimum circuit size requirement listed above, a new circuit must be installed for this machine.

Grounding

	WARNING	Improper grounding can cause electric shock, fire, and equipment damage.
-------------------------------------------------------------------------------------	----------------	---------------------------------------------------------------------------------

Proper grounding reduces the risk to the operator in the event of electrical malfunction or breakdown. This machine must be connected to the grounding conductor when available, and all grounding connections must meet or exceed the electrical code requirements in your area. Furthermore, all grounds must be verified and must meet or exceed the electrical requirement of the machine. If grounding is not available, consider the use of a GFCI protection device as an alternative, if this complies with the electric code in your area. When in doubt, consult a licensed electrician in your area.

Electrical Wiring

This machine is pre-wired for 115V, with a cord and a NEMA 5-15 plug. Please refer to the section “Wiring Diagrams” on page 60 for rewiring this machine to a 230V power source. The rewiring work requires a different power switch (**Part #: 937910-001**) and a 230V compatible plug. In addition, the rewiring work must be performed by a licensed electrician or the warranty is void.

The use of an extension cord is not recommended. If you need to use an extension cord to connect to a power source, select a durable cord type with a high-temperature rating (90C° or above). Use the minimum amount of extension cord as needed.

Minimum cord size (AWG) required based on amperage draw and length of the cord:

Amps	Power Cord Length			
	25 feet	50 feet	75 feet	100 feet
<i>8 to 12</i>	14	14	12	10
<i>12 to 15</i>	12	12	10	10
<i>15 to 20</i>	10	10	10	NR
<i>21 to 30</i>	10	NR	NR	NR

*NR: Not Recommended



Use properly sized wires that meet or exceed the power requirement of your machine. Using undersized wires may cause overheating and increase the risk of fire and machine damage.

Setup

Shop Preparation

Space Requirement

The dimensions of the table saw with 36" rail is 67"(L) x 31-1/2"(D). For the 52" rail model, the dimensions is 83"(L) x 31-1/2"(D). You will need additional space for manipulating your workpiece, additional support table/rollers, electrical connection, and dust collection.

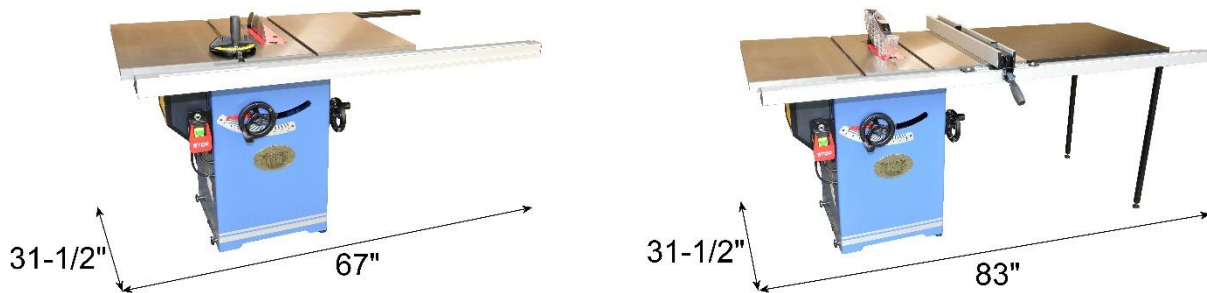

Load Limits

The entire shipment has a shipping weight of up to 367 lbs., and the fully assembled table saw has a net weight of up to 304 lbs. Please ensure all lifting tools and building structures have adequate load capacity, for transporting and supporting the total weight of this machine, the operator, and related items.

Electricals

Make sure a properly sized circuit and electrical outlet are available near the machine. Please refer to section "Electricals" on page 14 for details regarding electrical requirements.

Lighting

Adequate lighting is needed for operating this machine. Overhead, non-glare lighting should be installed.

Safety Labels

If this machine introduces a new safety hazard to your workplace. Please display proper warning signs in a highly visible location(s).

Dust Collection

Wood dust created by this table saw is a health hazard. Connect this machine to a dust collection system. Check air suction strength regularly to ensure dust and shavings are effectively removed. High-quality dust masks should be available for using the table saw.



Air resistance and leakage in a dust collection system impact its effectiveness. Use a dust collection system that is rated above 500 CFM at the dust port. Doing so improves air quality in the workplace, and prevents the machine from jamming.

Receiving

Your shipment should arrive in multiple packages. Upon receiving your shipment, please verify all packages are delivered. Check for any significant damages before signing the delivery confirmation.

IMPORTANT

If items are missing or damaged, please call us immediately at **1-800-559-5065**

For stock# 10040.101 with 36" rails, there are 2 packages:

1. Table saw with accessories in a crate.
2. 36" table saw rail assembly packed in a cardboard box.



For stock# 10040.102 with 52" rails and extension table, there are 3 packages:

1. Table saw with accessories in a crate.
2. 52" table saw rail assembly packed in a cardboard box.
3. Right extension table assembly packed in a cardboard box.



Moving Machine into the Shop

Your machine will be delivered by freight service, and it will be left outside of your workshop by default. On the day of delivery, please be sure help is available to move the machine to its final location.



WARNING

The crate of 10040 Table Saw weighs 324 lbs. and the fully assembled saw can weigh up to 304 lbs. Safe moving techniques and proper lifting equipment are required, or serious personal injury may occur.



WARNING

Your packages may be secured by the straps. Do not lift your packages by the strap. They are not designed to hold the total weight of your package. They may snap without warning and cause serious injury and machine damage.

Unboxing

The wood crate contains the table saw and two boxes:

- One box contains the cast iron extension wing.
- The second box contains accessories including the fence and the blade guard assembly.
- NOTE: The miter gauge and the blade wrench are mounted on the accessory storage plate on the right side of the saw.

In addition:

- The box with the rails contains the front and rear rails, and the mounting hardware.
- The box with the right extension table (Stock #10040.102 only) contains the table, legs, rubber leveling feet, and mounting hardware.



The cast iron extension wing is heavy. Please handle with care and wear protective footwear.



Always wear safety goggles and gloves when removing packing straps for securing your package. Straps may spring back violently when released and cause injury.

Inventory

Carefully unwrap the packaging and make sure all components are included in the shipment. Inventory all items received and put them in groups.

Group 1 – Tabled Insert Assemblies

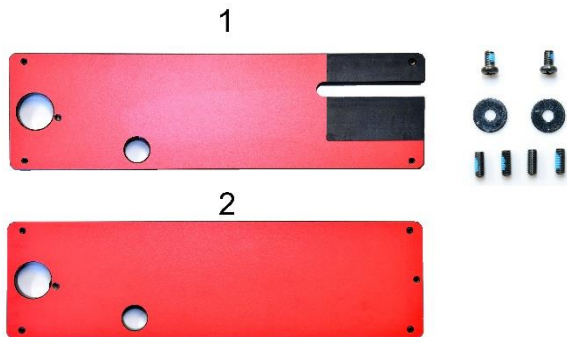

Item	Description	QTY
1	Zero Clearance Insert & Hardware	1 Set
2	Zero Clearance Dado Insert	1

Group 2 – Fence Assembly

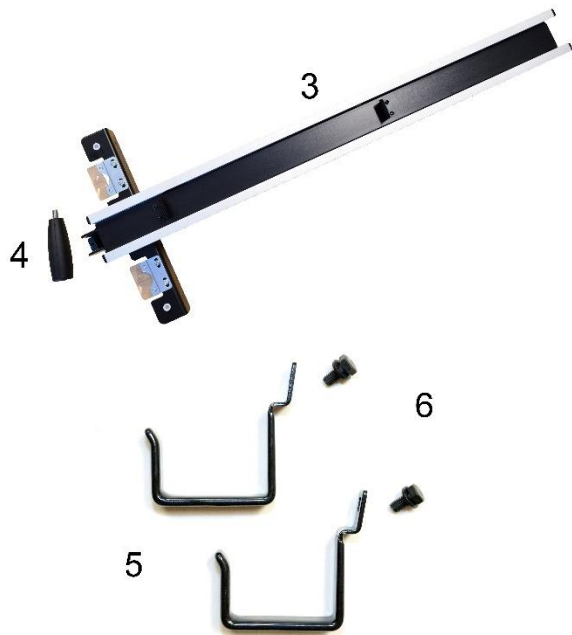

Item	Description	QTY
3	Fence	1
4	Fence Handle	1
5	Fence Storage Brackets	2
6	Fence Storage Bracket Mounting Screws	2

Group 3 – Blade Guard Assembly



Item	Description	QTY
7	Blade Guard Assembly	1

Group 4 – Cast Iron Extension Wing

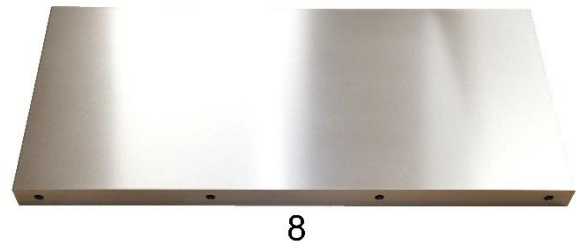

Item	Description	QTY
8	Cast Iron Extension Wing	1

Group 5 – Rails

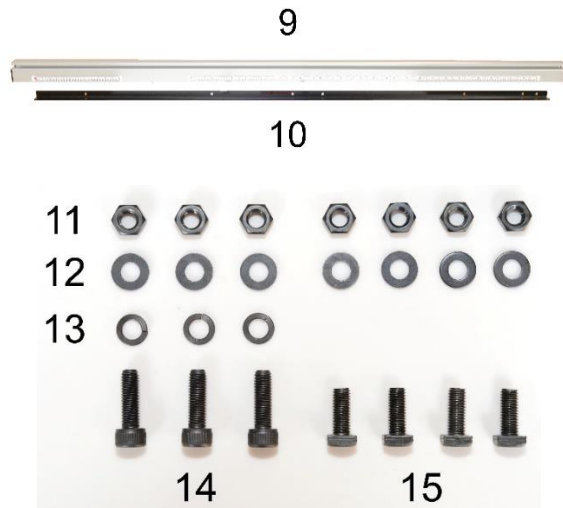

Item	Description	QTY
9	Front Rail	1
10	Rear Rail	1
11	M8 x 1.25 Nuts	7
12	M8 Washers	7
13	M8 Spring Washers	3
14	M8 x 1.25 Cap Screws	3
15	M8 x 1.25 Square Bolts	4

Group 6 – Tools



Item	Description	QTY
16	Push Stick	1
17	11/13mm Wrench	1
18	Hex Wrench (2.5/6mm)	1 Set

**Group 7 – Right Extension Table Assembly
(Stock 10040.102 only)**



Item	Description	QTY
19	Extension Table	1
20	Table Legs	2
21	M8 x 1.25 Cap Screws w/ Spring Washers	4
22	M8 x 1.25 Square Nuts	4
23	M8 Washers	8
24	M8 x 1.25 Nuts	8
25	Leveling Feet	2
26	Locking Nuts	2

**Group 8 – Tools Already Mounted On Saw's
Storage Plate**

Item	Description	QTY
27	Table Saw Blade Wrench	1
28	Miter Gauge	1

NOTICE: If you cannot find an item in the list above, please check if it is still attached to the packaging. Occasionally the item may have been pre-installed in the factory. See section “Parts List” to check if a component is included or installed.

NOTICE: This machine comes with various standard-sized, non-proprietary parts. If any of these parts are missing, we are happy to deliver them to you. To have the machine up and running as soon as possible, you can also find these parts at your local hardware store.

Additional Items Recommended for Machine Assembly

<i>Item</i>	<i>Purpose</i>
Safety glasses	Protection
Disposable gloves	Protection
Paper Towel	Cleaning
WD-40	Cleaning
Rust Inhibitor	Cast iron table top rust protection.
Straight Head Screw Driver	Machine Assembly
Philips Head Screw Driver	Machine Assembly
Machinist Square / Combination Square / 1-2-3 Block	Calibration
45° Machinist Square / Protractor / Quick Square	Calibration
Dial Indicator with Miter Slot Compatible Base	Calibration

Cleaning

To prevent rusting during shipment, the unpainted cast iron parts of the saw are covered with rust protectant and plastic film. Remove the plastic film and wipe off the rust protectant with paper towels. Make sure to clean the hard-to-reach areas such as the miter tracks and the areas around the table insert. WD-40 can thin the rust protectant to make it easier to remove.

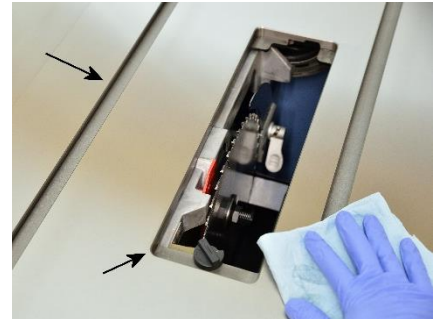

Once all rust protectant is removed, routinely coat the table with rust preventive such as Boeshield® T-9 or paste wax. Do not use rust preventives that contain silicone, which is known to interfere with certain finishes and glues.

Moving / Bolting Down the Table Saw

This table saw is equipped with casters so the saw can be easily moved around the shop. To keep the saw in place, use the locking knobs to lock the casters. The saw can also be bolted on the floor using the bracket shipped with the saw.



Essential Checks Before Assembly

This table saw has been tested and calibrated before leaving the manufacturing facility. It should not require extensive adjustments. The essential checks provide an opportunity to get familiarized with the saw, and it helps to discover any potential issues before the final assembly.



Make sure the table saw is unplugged before the first test!

Test 1: Turnion Inspection

1. Remove the table insert if it is installed.

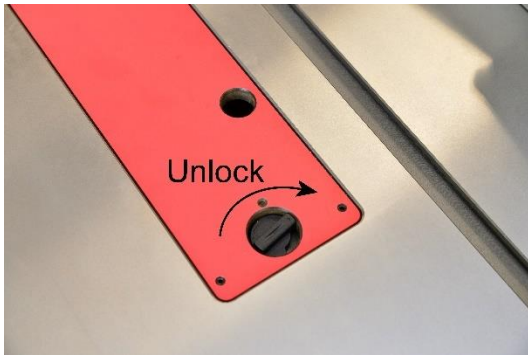

2. This saw should arrive with the 10" saw blade pre-installed. If not, see the steps in section "Changing Saw Blade" on page 44 to install the saw blade.
3. Use the blade tilt handwheel to set the blade to 0° so it is perpendicular to the table°.

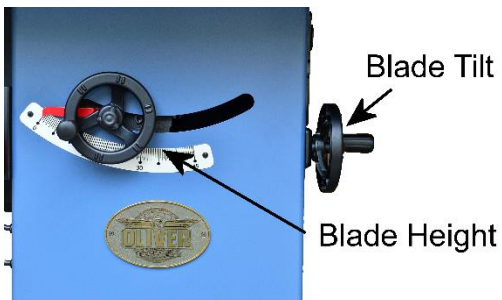

4. Lower the blade completely using the blade height handwheel. Verify the blade can be lowered to a position so a brand new zero clearance table insert can be installed without touching the blade. This allows new table inserts to be slotted safely.



5. Raise the blade to its maximum height. The blade should be at least 3-1/8" above the table.

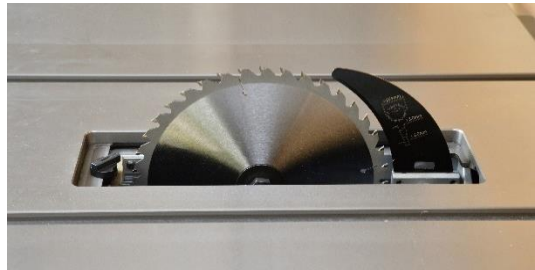

6. Set blade tilt to 45°. The highest point of the blade should be at least 2-1/4" above the table.



Test 2: Blade / Miter Slot Alignment Check



This test involves moving the blade. Wear thick leather gloves to prevent injuries from accidental blade contact. Remove the gloves before operating the saw.



1. Raise the blade to the maximum height and set blade tilt to 90°
2. Use a permanent marker to set a reference point near the edge of the saw blade. Move the reference point towards the front of the saw, then measure the distance between the blade and the miter slot.

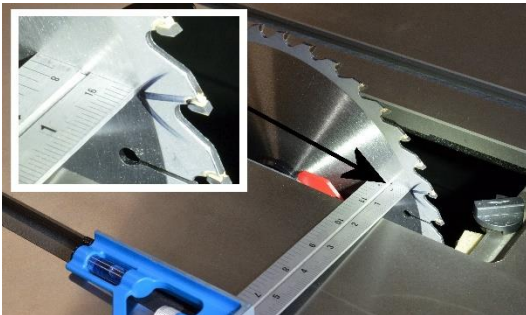

Using a dial indicator with a base that glides along the miter slot will result in a more accurate measurement.



3. Move the reference point towards the rear of the saw and measure the distance.

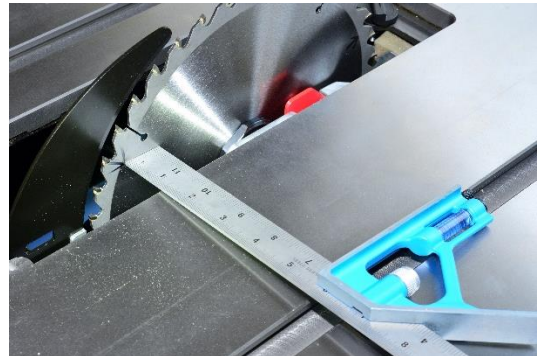

4. If the blade is perfectly aligned with the miter slot, the distance measured at the front and in the back should be the same. If the difference is greater than 0.008", refer to section "Blade to Miter Slot Alignment" on page 45 and make adjustments.

Test 3: Riving Knife Alignment Check

1. Raise the blade to its maximum height.
2. This saw should arrive with the riving knife installed. If not, install the riving knife.
3. Make sure the riving knife is completely inserted into the quick release slot, and the locking lever is pushed down into the locked position.

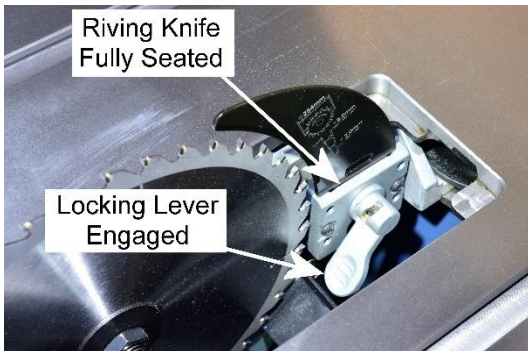

4. Place a straight edge across the table opening and against the saw teeth. Make sure the riving knife is in parallel with the blade, and it is staying within the alignment zone. Repeat the check on the other side of the saw blade.

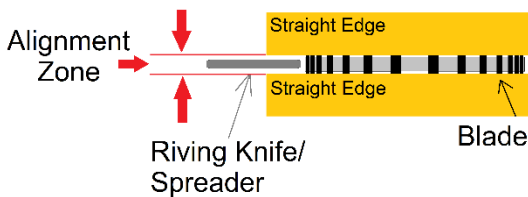

The alignment zone represents the slot of a workpiece cut by the blade. If the riving knife drifts beyond the alignment zone, it will either catch the workpiece or push the workpiece sideways. This will increase the risk of kickback and impact cut quality.

5. Check the height of the riving knife. It needs to be 1-5mm (approx. 3/64" - 13/64") below the saw blade. This ensures the riving knife does not catch the workpiece and provides maximum protection against kickback.

**Height Difference:
1-5mm (3/64" - 13/64")**

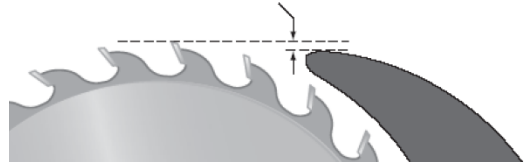

6. Check the distance between the riving knife and the saw teeth. It should have a clearance between 3-8mm (approx. 1/8" - 5/16"). This ensures there is enough room to clear the sawdust and wood chips.

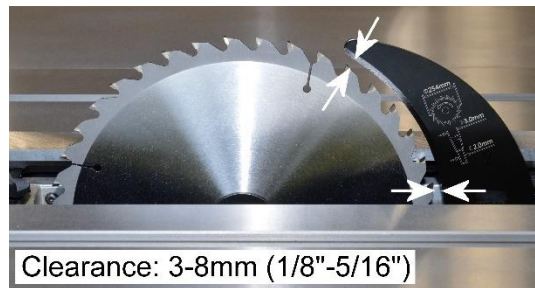

Test 4: Spreader Alignment Check

1. Remove the riving knife and install the blade guard assembly.
2. Loosen the blade guard locking knob and remove the blade guard.

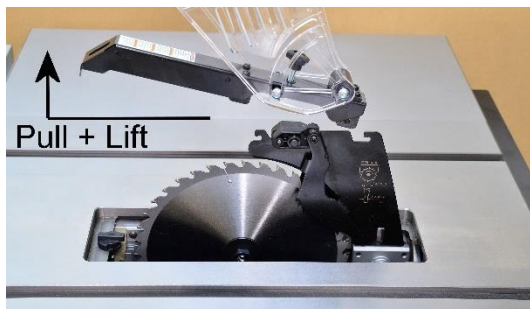
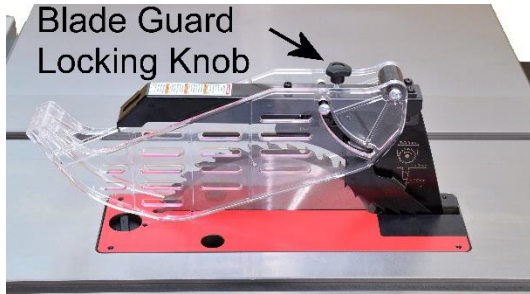

3. With only the spreader mounted, use a straight edge to verify the spreader aligns with the blade and is staying within the alignment zone.

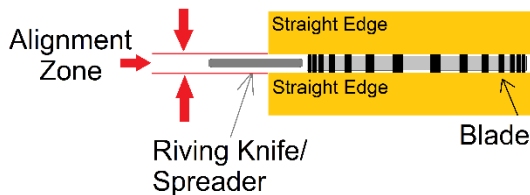

4. Lower the blade completely, then re-install the blade guard and the table insert before conducting the motor and switch test.

Test 5: Motor and Switch Functionality

1. Put on safety goggles and ear protection.
2. Connect the saw to the power source.
3. Press the green "ON" button to turn on the saw. The table saw should run smoothly with minimum vibration.



4. Unplug the saw. Wait for a few seconds until the motor comes to a stop, then plug in the saw again. The saw should not start. The magnetic power switch turns off automatically when the saw is disconnected from power. The saw will only turn on again when the operator presses the "ON" button.
5. Press "OFF" to turn off the saw. The motor should come to a stop.
6. Disconnect the saw from power.

If no issues were found from the tests, please continue to assemble the table saw. Otherwise, please refer to "Maintenance" on page 52 and "Troubleshooting" on page 55 to correct the issues.

Assembly

Extension Wing Installation

1. Remove the bolts and washers from the main table.

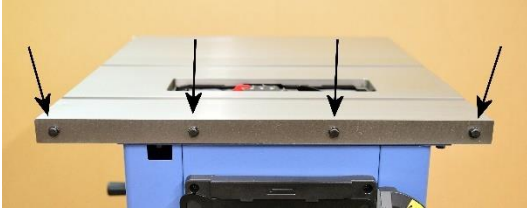

2. Check the mating edges of the extension wing and the main table and make sure it is clean and flat.
3. Use a lifting table or ask another person to hold the extension wing in place, then mount the extension wing with the provided bolts and washers.

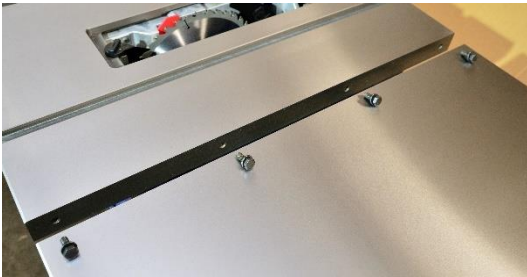

4. While tightening the bolts, make sure the top and the front surfaces of the extension wing are flush with the main table.



5. If the extension wing slopes down from the main table, shim the bottom of the mating edge with masking tape, then remount the extension wing. Shim the top of the mating edge if the extension wing slopes up. The height difference between the edges of the extension wing and the table should be less than 0.025". Adjust the amount and position of tape for shimming as needed.
6. Remove any excess masking tape when the installation completes.

Table Saw Rails Installation

1. Gather the mounting hardware that comes with the rails package.



2. Insert four square bolts (#15) into the front edge of the table.



3. Insert the washer(#12) and the nuts(#11) loosely and keep the heads of the bolts protruding from the table.



4. Attach the rail by sliding the T-slot of the rail through all four square bolts.

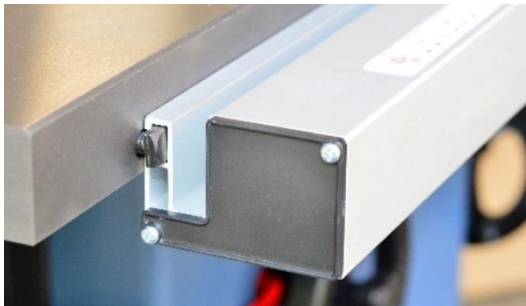

5. The left end of the front rail should recess approximately 1-1/8 to 1-1/4 from the left edge of the table.

6. When securing the front rail, make sure the rail runs in parallel with the table surface. The rail surface with the scale should be approximately 9/16" below the table surface.

7. Align the screw holes on the back of the table and the rear rail.

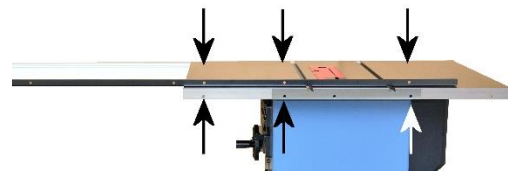

8. Mount the rear rail with the provided cap screws (#14), spring washers(#13), flat washers(#12), and nuts(#11). While tightening the cap screws, make sure the rear rail runs parallel with the table.

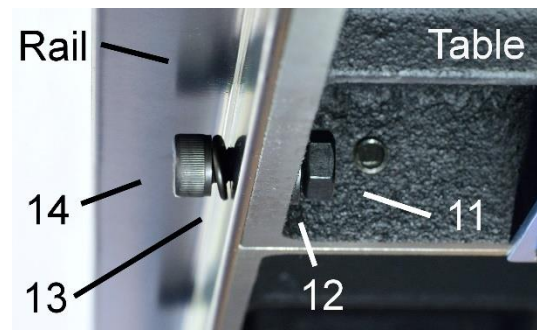

9. The top surface of the rear rail should be approximately 9/16" below the table.

Right Extension Table Installation (For Stock #10040.102 Only)

1. Gather the mounting hardware that comes with the extension table package.



2. Thread the locking nut (#26) into the leveling foot (#25), then install the leveling foot.



3. Insert two square bolts (#22) into the T-slot of the front rail. Then attach the flat washer (#23) and nuts (#24). These will be used for mounting the table.
4. Insert two more square bolts (#22) into the T-slot, then mount the support leg and secure it with a flat washer (#23) and nut (#24). Adjust the leveling foot so the leg provides support to the front rail without bending it. Lock the leveling foot by tightening the locking nut.

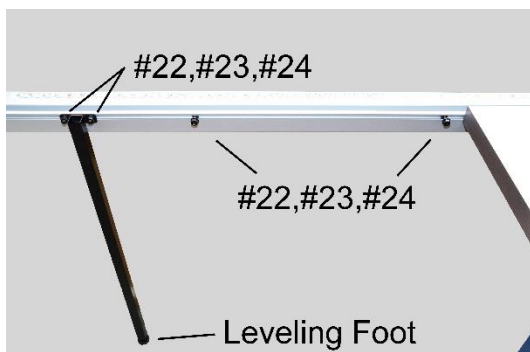

5. Insert two cap screws with spring washers (#21), into the rear rail and attach the washers (#23) and nuts (#24). These will be used for mounting the table.
6. Secure the support leg using the cap screws and spring washers (#21), washers (#23), and nuts (#24). Adjust the leveling foot so it is supporting the rear rail without bending it.

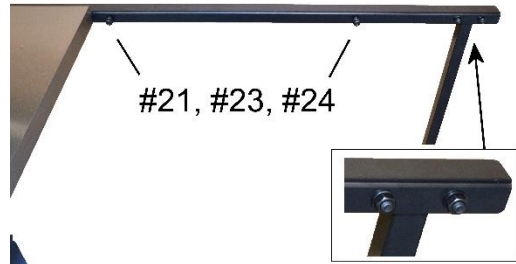

7. Adjust the position of the table mounting bolts so the support bracket of the table will sit right on top of them, then mount the table. Make sure the support bracket fits in between the rail and the washer.



8. While tightening the nut to secure the table, make sure the extension table is flush and parallel with the cast iron table.

Table Insert Setup

1. The table inserts may have the adjustment/locking hardware pre-installed at the factory. If not, it will come with a set of hardware. Follow steps 2-3 for installing the hardware.

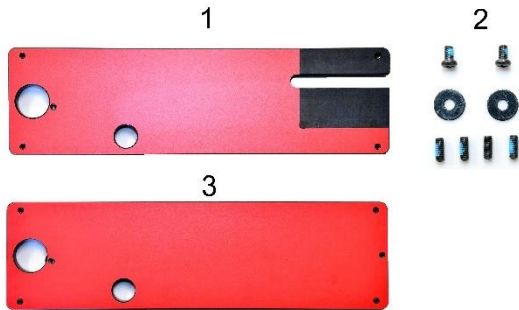

2. Hand thread the set screws from the top of the insert, then continue to thread the screws with a 2.5mm hex wrench until they are flush with the bottom of the insert.



3. Install the locking washer and screws from the bottom of the insert.



WARNING

The locking washers prevent a table insert from dislodging from the saw while the saw is running. They must be installed before use. Running the saw with improperly installed locking washers or without them can cause serious injuries or death.

4. Install the table insert and adjust the four set screws until the insert is flush with the table, then rotate the lock knob clockwise to secure the insert.



5. **NOTE:** The zero clearance table inserts must be cut before use. Please make sure the saw is calibrated, and the desired blade is properly installed before cutting the insert.
6. Before cutting the slot of the table insert, make sure the insert is locked securely on the table, and the blade is lowered completely.



7. Put on protective gear.



8. Connect the saw to a power source.

- Set the blade angle to 0° so the blade is perpendicular to the table.



- Clamp a piece of 2x2 on top of the insert where the slot will be cut. Doing so ensures the insert stays in place when it is cut and reduces the amount of dust released.



- Turn on the saw and slowly raise the blade to its maximum height.
- Turn off the saw. Lower the blade completely and remove the supporting board and clamps.

- To minimize tear-outs, the zero clearance table inserts should be cut for a specific blade tilt angle. If the insert needs to be used for the entire range of blade tilt, set the blade angle to 45°, then repeat steps 10-12 with a new board supporting the table insert.

⚠ WARNING ⚠

Only the regular zero clearance table insert (Part# 924397-001) can be slotted multiple times at different blade tilt angles.

The dado insert can only be slotted when the dado blades are perpendicular to the table. Attempting to slot the dado insert at a beveled angle can destroy the dado insert, and may cause severe injuries.

⚠ WARNING ⚠

Slotting a homemade table insert at different angles may create debris that is large enough to get caught in between the blade and the dust shroud. The debris can become a high-speed projectile when struck by the blade. This hazardous situation can cause serious injury to the operator and damage the table saw.

- Disconnect the table saw from power after setting up the table insert.

Fence Setup

1. Gather the fence storage brackets and the mounting bolts. Item #5 and #6.



2. Mount the fence storage brackets on the back of the cabinet.

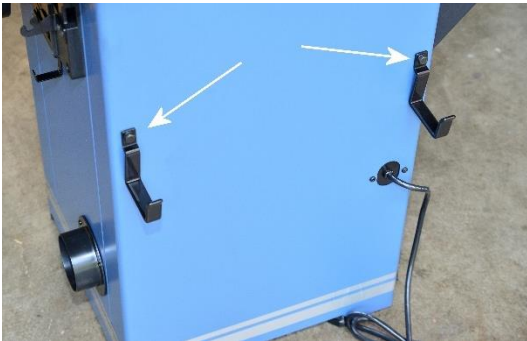

3. Install the fence handle.

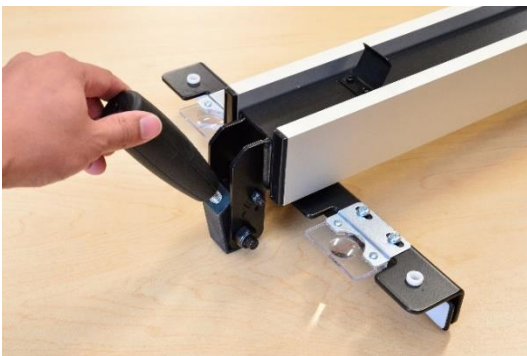

4. Mount the fence onto the front rail.
5. Make sure the fence aligns with the miter slot. To check the alignment, line up the fence against the edge of the miter slot and make sure they run in parallel. Using a dial indicator with a miter slot compatible base will result in a more accurate measurement.

Refer to section “Fence to Miter Slot Alignment” on page 46 for details about checking and readjusting the fence to miter slot alignment.



6. Use a square to verify the fence face is perpendicular to the table. Refer to section “Fence Squareness Adjustment” on page 47 if adjustment is needed.

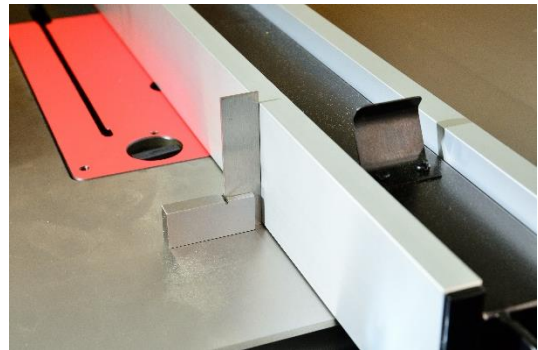

7. The fence should be floating on top of the cast iron table and only supported by the rails. Use a feeler gauge or a piece of cardboard to make sure there is a gap of 1/16” between the fence face and the table. Refer to section “Fence Height Adjustment” on page 47 if adjustment is needed.



8. Raise the blade and slide the fence until it is barely touching the blade.

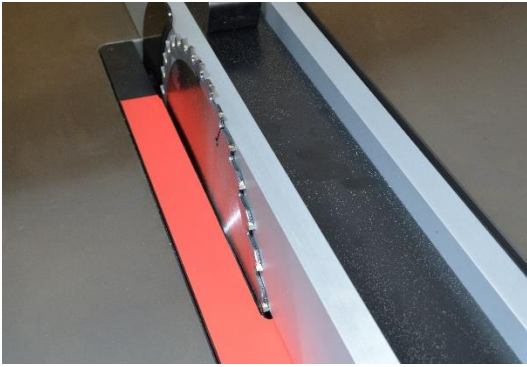

9. Check the readings on the scale to see if the reading is 0". If so, the fence is set up. Otherwise, continue with the next step.

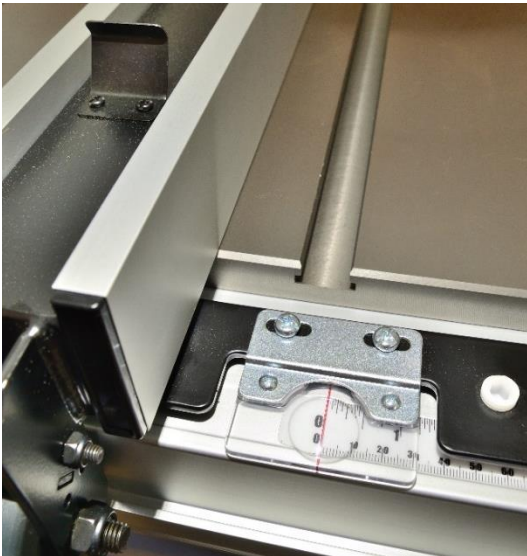

10. Loosen the nuts that secure the front rail.
11. Adjust the position of the rail until the reading is zero while the fence is barely touching the blade.
12. Re-tighten the nuts to secure the front rail.
13. Lower the saw blade when the fence is set up.

Push Stick Storage

This table saw comes with a push stick which can be attached to the fence. This convenient feature keeps the push stick around when it is needed. To attach the push stick:

1. Place the notch of the push stick against the push stick holding bracket on the fence.
2. Then firmly push down the push stick handle onto the fence so the push stick is held in between the brackets.

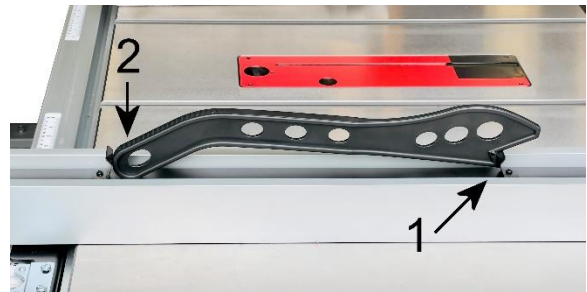

Dust Collection

The use of the table saw will generate wood dust which is harmful to the body. Connect this machine to a dust collection system.

The minimum CFM requirement for this table saw is 500 CFM at the dust port, which means the dust collection system should have a rating greater than 500 CFM, as air friction and leakage can reduce effective CFM at the dust port.



IMPORTANT

Running this table saw without a dust collection system, or using a dust collection system with inadequate suction may damage the machine and cause other hazardous situations. Check your dust collection system regularly to make sure it is not jammed or filled up.

Accessories

*Zero-Clearance Table Insert (Part #: 924397-001) &
Zero-Clearance Dado Insert (Part #: A-10040.A005)*

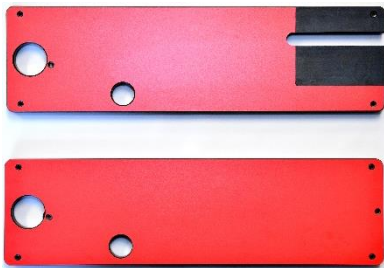

Zero clearance table inserts help reduce chip-outs and splintering. They also improve safety by preventing thin cuts and debris from getting trapped between the blade and the insert. Use a zero-clearance insert that matches the kerf of the saw blade.

These OEM table inserts are made of high-density phenolic which is durable and stable for temperature and humidity changes.

Pre-Cut Dado Table Insert (Part #: 924531-001)



Made from the same material as the zero clearance table insert, the pre-cut dado insert is available as a replacement part.

Power Switch for 230V Wiring (Part #: 937910-001)



This table saw is prewired to 120V. To rewire this saw for a 230V power source, power switch **#937910-001** is required. Refer to the wiring diagram and have the rewiring work completed by a licensed electrician.

Touchup Paint



Keeping all painted surfaces in good condition not only makes your machine look nice but also keeps rust away. Oliver Machinery has pre-mixed spray paint available in Oliver-Blue for purchase.

Accessories are available on our website: **OLIVERMACHINERY.NET**

To order by phone, please call us at **1-800-559-5065**. We are available Monday through Friday, 7:30 AM - 4 PM Pacific Time. You can also email us at **PARTS@OLIVERMACHINERY.NET** to purchase accessories.

Please visit our website at **OLIVERMACHINERY.NET** for additional recommended accessories.



WARNING

Using unapproved accessories may cause the machine to malfunction, which can result in serious injury and/or machine damage. Only use accessories recommended for this machine.

Operation

The table saw is recognized as one of the most dangerous tools in the shop and it should be treated with respect. This chapter provides general guidelines to operate a table saw safely. It is not intended as a substitute for formal woodworking training. Additional safety rules may be required to fit specific needs in various situations. When in doubt, please consult credible training resources for help.



WARNING

Similar to many other woodworking machineries, this table saw is **NOT** equipped with an emergency braking device that stops and retracts the saw blade upon contact with the human body. Operators must take all safety measures to **AVOID BLADE CONTACT**. Otherwise, serious injuries such as amputation or even death may occur.



WARNING

Kickback is another common cause of table saw accidents. Whenever possible, **INSTALL ANTI-KICKBACK DEVICE** such as blade guard or riving knife when using the table saw. Avoid standing in front of the saw blade to reduce the chance of getting stuck by a kickback projectile. Kickback accidents can cause serious injuries or even death.

Safety Guidelines for Preparing for a Cut

1. **KEEP THE SAW STATIONARY:** Make sure the caster lock knobs are tightened so the table saw is stationary. If the saw wobbles on an uneven floor, adjust the rubber leveling feet to keep it stable.



2. **INSPECT SAW BLADE:** The saw blade must be sharp, clean, balanced, and free of damage. A damaged saw blade can disintegrate while the saw is running and become a deadly projectile. Replace the saw blade when it is damaged, dropped, or dull. Forcing a dull blade to work invites accidents and impacts finish quality.

3. **INSPECT MATERIAL:** This table saw is designed for cutting natural and engineered wood materials. It can also cut non-shattering plastics with a high melting point. Make sure the material for cutting is dry, stable, intact, and free of foreign objects such as nails. The workpiece must have flat and stable surface(s) for feeding safely against the table plus the fence or miter gauge.



WARNING

DO NOT use this table saw to cut metal.

DO NOT cut any materials such as ceramic tiles that can disintegrate when it is cut.

Failure to comply will greatly increase the risk of accidents that can cause serious injuries or death.

- INSTALL BLADE GUARD** for through cuts whenever possible. A through cut is to cut through the entire thickness of a workpiece.

The blade guard is equipped with anti-kickback claws. It will stop or slow down the workpiece from shooting back toward the operator.

Insert the blade guard completely into the quick release slot and fasten it with the locking lever. Make sure the spreader aligns with the blade and is positioned in the alignment zone. Replace/repair the blade guard when it is damaged.

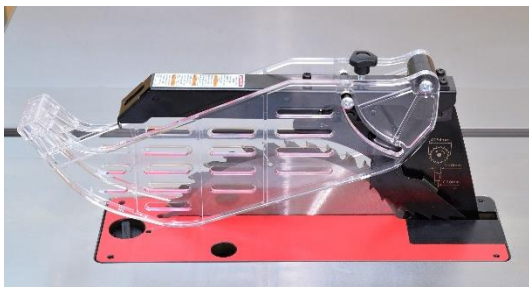

- INSTALL RIVING KNIFE** for non-through cuts, or when it is impossible to use the blade guard for a through cut. The riving knife prevents kickback by preventing a workpiece from latching onto the back of the spinning saw blade. Make sure the riving knife is inserted completely into the quick-release mechanism and fastened. It must be aligned with the blade and positioned within the alignment zone.

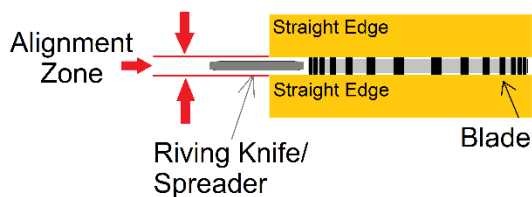

- CHANGING SAW BLADE:** Always disconnect the table saw from power before changing the saw blade. Failure to do so can result in amputation or death if the saw is accidentally turned on.

Only use saw blades that are sharp, clean, and free of defects. Choose the blade type that is designed for the material and the type of cut.

- BLADE ADJUSTMENTS:** Only adjust the blade height or blade tilt when the saw is off and the saw blade comes to a complete stop. The blade height should be 1/4" more than the thickness of a workpiece.

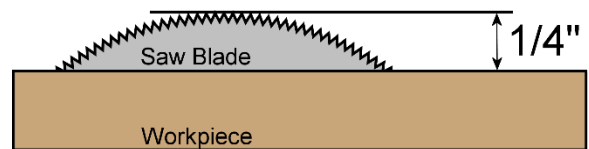

After blade adjustments, make sure the blade is not in contact with the blade guard, riving knife, table inserts, fence, and/or the workpiece. Many homemade zero clearance table inserts only work at a specific bevel angle and may catch the blade at a different angle.

- FENCE SETUP:** Check fence alignment against the blade and miter slot before using the saw for the first time, then perform routine checks afterward. The workpiece can bind with the saw blade if the distance between the fence and the blade in the front is GREATER than the distance in the rear. This will increase the risk of kickback.

The fence must be in parallel with the saw blade and the miter slot, or have an offset of less than 1/64" to the right when measuring at the rear of the table.

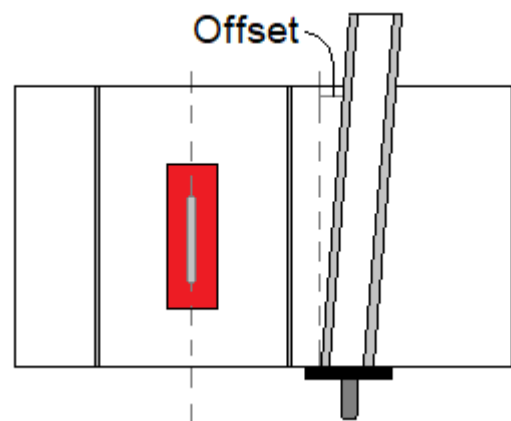

ALWAYS lock the fence and make sure the fence is not touching the blade before starting the table saw.

9. **MAKING CROSS CUTS** using a miter gauge allows stable feeding and reduces the risk of kickback accidents.

NEVER use the fence as the stop block when cutting with a miter gauge, as this allows a workpiece to bind with the blade and increases the risk of kickback.



10. **CUTTING ODD SHAPE WORKPIECES:** Avoid cutting odd-shaped workpieces on a table saw whenever possible. To cut an odd-shaped object, it must be securely fastened on a special jig that allows the operator to feed the workpiece safely.
11. **DADO BLADES:** When installing dado blades, make sure all saw blade teeth are distributed as evenly as possible. Never allow the saw blade teeth to stack on each other as that can bend the dado blades and alter the width-of-cut.
12. **SUPPORT LONG/WIDE WORKPIECE** with rollers or other devices on both infeed/outfeed sides of the saw to avoid injuries.
13. **REHEARSE A CUT** especially for cutting large/wide workpieces to ensure there is enough room to clear the workpiece. Also, make sure the workpiece and the cut-out are supported throughout the entire cut.
14. **EYE PROTECTION:** Always wear an approved safety face shield, goggles, or glasses that complies with ANSI Z87.1 and CSA Z94.3 standards. Common eyeglasses are not safety glasses, and may not provide adequate protection.

15. **EAR PROTECTION:** Use hearing protective devices where the noise exceeds the level of exposure allowed in section 1910.95 of the OSHA Regulations. When in doubt, use it.

Duration Per Day, Hours	Sound Level DbA Slow Response
8	90
6	92
4	95
3	97
2	100
1½	102
1	105
½	110
¼ or less	115

16. **OTHER PERSONAL PROTECTION:** Before using the table saw, remove the tie, rings, watch, and other jewelry. Roll up sleeves above the elbows. Remove all loose outer clothing and confine long hair. Protective footwear should be used. Do not wear gloves when operating the table saw. Wear gloves to perform maintenance work when the saw is unplugged.
17. **DUST HAZARD:** Connect the table saw to a dust collection device and enable dust collection before work begins. Wear a dust mask to prevent inhalation of harmful wood dust. Avoid cutting wood species that are known to trigger allergic reactions.
18. **ADDITIONAL ANTI-KICKBACK DEVICES** such as featherboards or anti-kickback rollers can prevent kickback or slow down the projectile when they are properly installed.
19. **PROPER USE:** Do not use this machine for anything other than its intended use. If used for other purposes, Oliver Machinery disclaims any real or implied warranty and holds itself harmless for any injury or damage which may result from that use.

Safety Guidelines for Using the Table Saw

1. **STAY ALERT** at all times. Do not operate this machine while under the influence of drugs/alcohol, or when not feeling well
2. **HAND POSITIONING:** Keep hands and any body parts at least 6" away from the saw blade. Using a push stick can keep hands away from the saw blade while maintaining control of the workpiece.
3. **STANCE AND BODY POSITIONING:** Maintain a balanced stance and never overreach while feeding a workpiece.
4. **PREVENT KICKBACK INJURIES:** Avoid standing right in front of the saw blade when feeding a workpiece. Failure to do so exposes the body to the fast traveling projectile when kickback occurs, and this can result in serious injuries or death.
5. **USE PROPER FEEDING TECHNIQUE:** Allow the saw blade to reach full speed, then feed the workpiece at a speed that allows the blade to make a clean cut without burning the cut edge. Feed the workpiece securely against the table plus the fence, miter gauge, or other support jigs. The feeding direction must be in parallel with the blade.
6. **BAD FEEDING TECHNIQUES** will greatly increase the risk of accidents and must be avoided:
 - **NEVER** perform freehand cuts.
 - **NEVER** feed a workpiece sideways.
 - **NEVER** pull a workpiece from behind the blade.
 - **NEVER** rotate the workpiece towards the rear of the blade while feeding.
 - **NEVER** back out a cut. If it is impossible to complete a cut, stop the saw while holding the workpiece securely, then remove the workpiece after the blade comes to a complete stop. If the guard must be removed to back out a piece, promptly reinstall the guard afterward.
 - **NEVER** reach behind or over the blade while feeding.
 - **NEVER** perform plunge cut, except for preparing a zero-clearance table insert (See page 29 for details). Extra caution must be taken.
7. **REMOVING CUTOFFS** frequently when making multiple repeating cuts. ALWAYS turn off the saw and wait for the blade to come to a complete stop before removing cut-off pieces. Failure to do so can cause kickback accidents, and/or allow a cut-off piece caught in between a running blade and the table insert.
8. **DADO/RABBET CUTS:** Blade guard / riving knife has to be removed when cutting a dado or rabbet. Extra caution must be taken to avoid blade contact and kickback accidents. To avoid kickback accidents, a deep non-through cut can be done in multiple light passes.

Making a Rip Cut

A rip cut is to cut a workpiece lengthwise. When working with materials with directional wood grains, this typically means cutting along the grain.

1. Use the blade guard for making a through cut, or use the riving knife for a non-through cut.
2. Adjust the fence to set the width of cut. A rip cut must be performed with the fence.
3. Adjust the blade so it protrudes 1/4" or less above the workpiece.

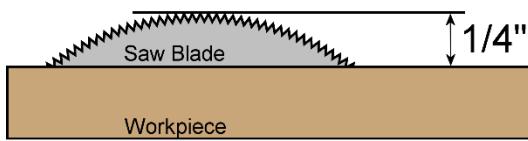

4. Rehearse the cut mentally to plan for the stance and hand placement throughout the entire cut. Prepare to use push stick(s) if feeding a workpiece gets the hands close to the saw blade. The hands should be at least 6" away from the saw blade.

When cutting a big workpiece, make sure it is supported throughout the entire cut, and there is enough room to clear the workpiece.

5. When making a narrow cut or cutting smaller workpieces, using additional support such as featherboards can help stabilize the workpiece and prevent kickbacks. Quality featherboards can be purchased at local woodworking supplies stores.

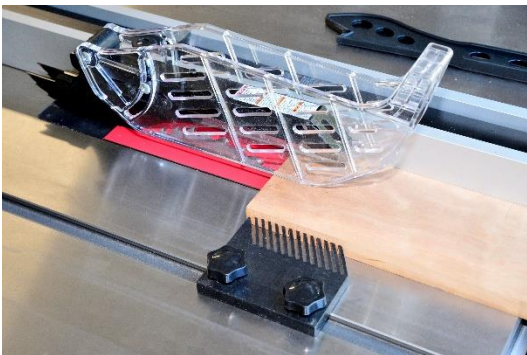

6. Before starting the saw, make sure the blade is not in contact with the workpiece or any guides or guards.
7. Remove pencils, measuring tape, and other items from the table before starting the saw.

8. Turn on the dust collection device and start the saw.
9. Begin the rip cut by holding the workpiece firmly against the fence and the table surface. Feed the workpiece towards the blade. Stay alert and maintain a steady feed rate.



10. When the hand is getting close to the saw blade, use a push stick to finish the cut.



When feeding a workpiece with a push stick, position the push stick close to the blade. Doing so prevents the workpiece from rolling into the blade and kicking back towards the operator.

11. Keep feeding the workpiece until it clears the blade guard or riving knife, then turn off the saw. Wait for the blade to come to a complete stop before retrieving the workpiece.
12. To prevent kickback, never back out a cut while the blade is still spinning. If it is necessary to stop a cut in the middle of the process, stop the saw and wait until the blade comes to a complete stop, then remove the workpiece.

Making a Cross Cut

A cross cut is to cut across the width of the workpiece. When working with materials with directional wood grains, this typically means cutting across the end grains.

1. Use the blade guard for making a through cut, or use the riving knife for a non-through cut.
2. Adjust the blade so it protrudes 1/4" or less above the workpiece.

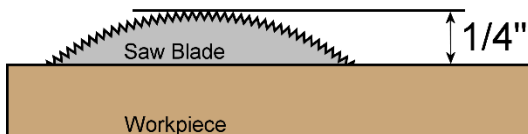

3. Use the provided miter gauge to support the workpiece for the cross-cut.



4. Mark the workpiece to set the width of cut.

⚠ WARNING ⚠

NEVER use the fence to set the width when making a cross-cut. The workpiece can bind to the blade and kick back towards the operator. Remove the fence to provide room for the cutouts to prevent kickback.



5. Hold the workpiece against the miter gauge, then place the setup near the blade. Adjust the position of the workpiece to line up the

cut. When the position is set, pull the setup away from the blade.

6. Before starting the saw, make sure the blade is not in contact with the workpiece or any guides or guards.
7. Remove pencils, measuring tape, and other items from the table before starting the saw.
8. Turn on the dust collection device and start the saw.
9. To begin a cross cut, hold the workpiece firmly against the miter gauge and the table surface. Feed the workpiece towards the blade. Stay alert and maintain a steady feed rate.

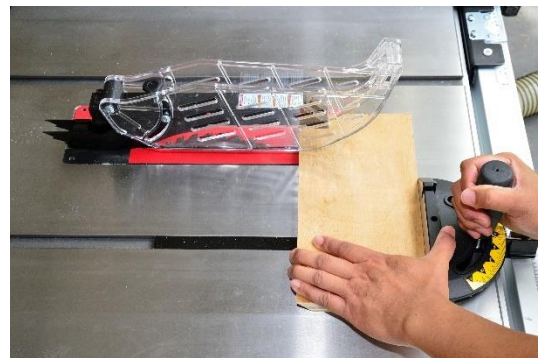

10. When cutting across the end grain, keeping a slower feed rate can reduce tear-outs. However, it may increase the chance of burning the cut edge.
11. Keep feeding the workpiece until it clears the blade guard or riving knife, then turn off the saw. Wait for the blade to come to a complete stop before retrieving the workpiece.
12. Never back out a cut while the blade is still spinning. If it is necessary to stop a cut in the middle of the process, stop the saw and wait until the blade comes to a complete stop, then remove the workpiece.
13. Some woodworkers use custom-made crosscut sleds for cross cuts. Always keep hands at least 6" away from the blade when using a crosscut sled. The sled should be built to keep hands away from the blade.

Notes for Making a Miter Cut

A miter cut is a cross cut made at a miter angle.

1. The provided miter gauge has a range from 60° left to 60° right. To adjust the miter angle, loosen the handle and pull out the quick-adjust pin.

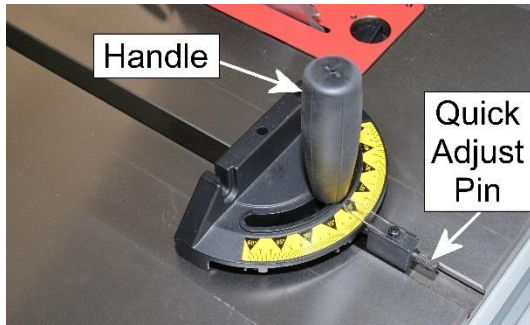

2. There are three positive stops at 45° left, 0°, and 45° right. To use the positive stops, push in the quick-adjust pin and adjust the angle until the quick-adjust pin pushes against the positive stops.
3. Tighten the handle to lock the miter angle when adjustment completes.
4. When feeding a workpiece at a steep miter angle, the workpiece may get pulled sideways by the resistance of cutting. Make sure the workpiece does not slide by holding it firmly against the miter gauge for the entire cut.

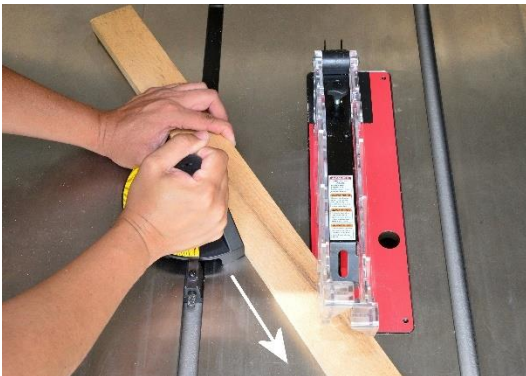

Notes for Making a Bevel Cut

A bevel cut is performed with the blade tilted. Either rip cuts or cross cuts can be made at a beveled angle. When making a beveled cut, make sure the workpiece does not get pinched in between the blade and the table.

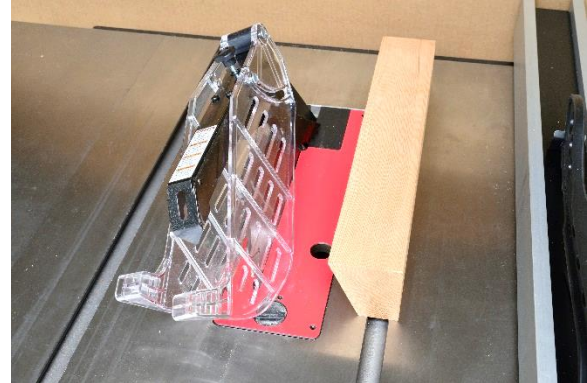

WARNING

Never use the miter gauge on the left side of the blade when making a bevel cut. The blade guard will block the miter gauge.



If using a riving knife instead of a blade guard, the hands will get dangerously close to the blade as shown in the picture below. If kickback occurs, the hands may get pulled towards the blade. This can result in amputation and serious injuries.



Cutting with Dado Set

1. Dado set is a set of stackable blades that can cut a dado or a rabbet in a single pass. This table saw accepts dado blades up to 8" in diameter, with combined kerf up to 3/4".

IMPORTANT

This saw does not include a dado insert that allows the dado set to make beveled cuts.

2. Dado and rabbet cuts can only be performed without the riving knife/blade guard. Be extra cautious when feeding the workpiece without an anti-kickback device. Reinstall the blade guard immediately after cutting with the dado set.



3. Follow the dado set manufacturer's instructions and install the number of blades and shims to set the width-of-cut. When installing the dado set, make sure the saw blade teeth are distributed as evenly as possible.
4. Never allow the saw blade teeth to stack on each other. That can alter the width-of-cut and possibly damage the dado set. Also, make sure all the blades are arranged in the correct orientation.

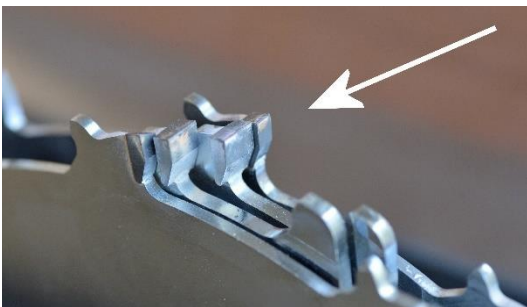

5. Adjust the blade height to set the depth of cut, then lock the blade height handwheel to make sure the depth of cut stays consistent. When making a deep cut, make multiple passes with increasing depth.
6. The dado set is heavier than a standard saw blade, it can take longer for the blades to reach full speed and come to a complete stop. Be patient when working with a dado set.
7. Make test cuts on a scrap piece to verify the width-of-cut and depth-of-cut before cutting the actual workpiece.
8. To reduce chipping and tear-outs for intersecting dado/rabbet cuts, make cuts across the grain first, and then along the grain.

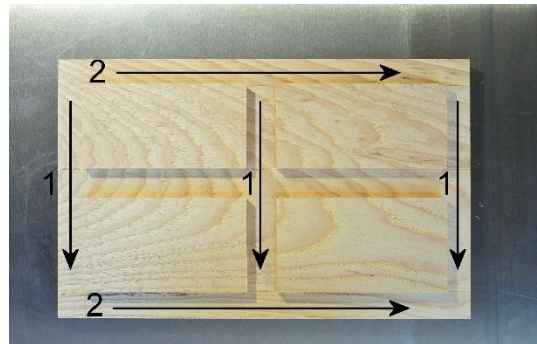

⚠ WARNING ⚠

Never use the dado set to perform a through cut. The dado set is much wider than a standard blade, and it is not designed to perform a through cut. Failure to comply will increase the risk of kickback which can cause serious injuries or death.

After Using the Table Saw

1. **STOP THE MACHINE** immediately after the work completes, or when the operator leaves the machine for any reason.
2. **WAIT** until the motor comes to a complete stop.
3. **LOWER** the saw blade so it goes below the table.
4. **CLEAN UP** before departure.
5. **LOCK** the power switch with a padlock. Doing so prevents the saw from accidental startups by an untrained person. If a lock is not available, unplug the saw.

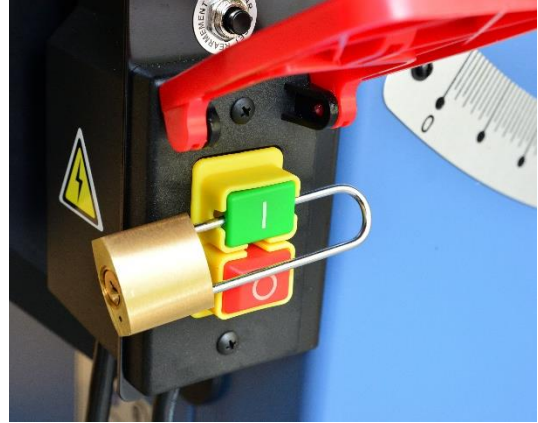

Changing Saw Blade



Please wear thick gloves to protect your hands when changing saw blades. The saw blade teeth are sharp and can easily cut through the skin when not protected.

1. Disconnect the saw from the power source.
2. Unlock and remove the table insert.



3. Raise the blade to the maximum height and set the blade tilt to 0°.
4. Lift the locking lever and remove the blade guard or riving knife.



5. Push the spring-loaded arbor lock to the right, then rotate the arbor until the arbor lock engages.

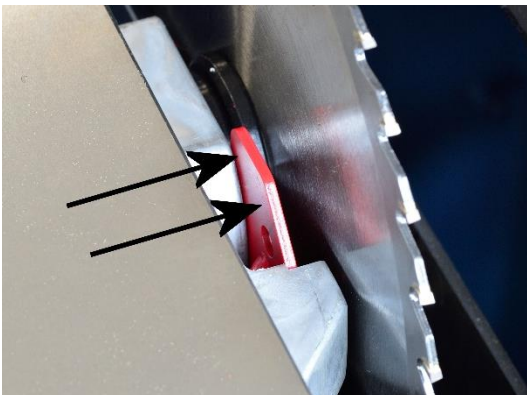

6. Loosen the arbor nut with the provided arbor wrench. Pull the wrench towards the front of the saw (rotate counterclockwise) to loosen the nut.



7. Remove the arbor nut, flange, and blade. Handle the blade carefully to protect your hands.
8. Install the saw blade of choice. Pay attention to the orientation of the blade teeth. Do not install the blade in reverse.
9. Install the flange. Make sure the wider base is facing the blade.
10. Install and tighten the arbor nut with the arbor lock engaged.

IMPORTANT

Do not over tighten the arbor nut as it is self-tightening. Over tightening the nut will make it difficult to remove in the future, and it can also damage the saw.

11. Reinstall the table insert and blade guard after changing the saw blade.

Calibrations and Adjustments

Blade to Miter Slot Alignment

The blade to miter slot parallelism is calibrated at the factory and should not require further adjustments. The factory tolerance is 0.2mm (approx. 0.008"). Check the blade to miter slot alignment before calibrating the fence.

IMPORTANT

For the best result, measure the alignment with a dial indicator mounted on a base that can glide along the miter slot. It is also possible to mount the dial indicator on the miter gauge. Make sure there is no play between all components. If a dial indicator is not available, it is possible to measure with a combination square or measuring tape. However, the result can be less accurate.

CAUTION

This test involves moving the blade. Wear thick leather gloves to prevent injuries from accidental blade contact. Remove the gloves before operating the saw.

1. Disconnect the saw from the power source.
2. Raise the blade to the maximum height and set the blade tilt to 90°
3. Use a permanent marker to set a reference point near the edge of the saw blade.
4. Move the reference point towards the front of the saw, then position the dial indicator so that its contact point rests on the reference point. Set the dial indicator to zero.

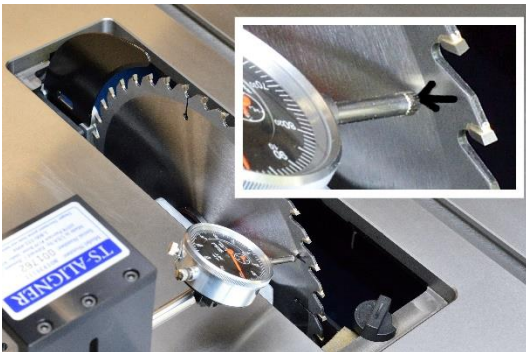

5. Move the reference point towards the rear of the table, then slide the dial indicator to the back so the dial indicator's contact point is again resting on the reference point.



6. Take the measurement, if the offset is greater than 0.2mm or 0.008", rotate the table to align the miter slot to the saw blade.
7. There are four table mounting bolts located at each corner of the cabinet. Loosen any three of them with a 13mm wrench.



8. Rotate the cast iron table in small increments until the blade aligns with the miter slot.
9. Tighten all table mounting bolts. Repeat steps [4-6] one more time to double check the alignment.

IMPORTANT

If the table has to be shifted significantly to align the miter slot, the zero clearance table insert will need to be re-slotted or replaced.

Fence Lock Tightness

If the fence cam lock becomes loose:

1. Remove the fence from the rail and rotate both set screws clockwise by 1/6 turn to increase the clamping pressure.

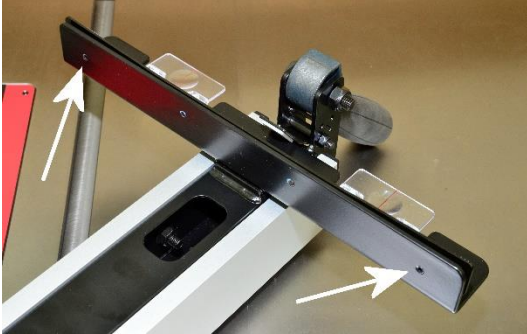

2. Reinstall the fence and recheck the cam lock tightness. Repeat step 2 as needed.
3. Check the fence to miter slot alignment and adjust as needed.

Fence to Miter Slot Alignment

To prevent kickback and to improve cut quality, the fence must align with the saw blade. When the miter slot aligns with the saw blade, it can be used to align the fence.

1. **Disconnect the saw from the power source.**
2. Mount the dial indicator on a base so it can glide along the miter slot.
3. Position the dial indicator near the front edge of the table.
4. Slide the fence towards the dial indicator so it engages the contact point of the dial indicator. Lock the fence and then set the dial indicator to zero.

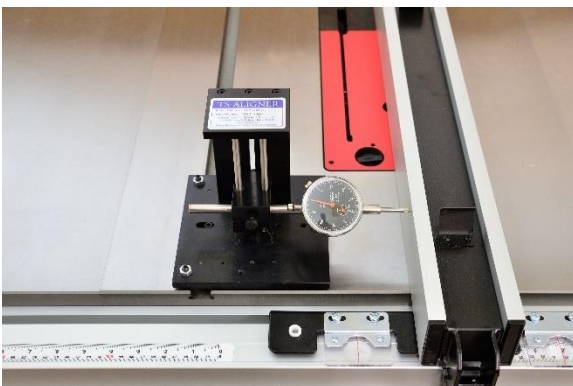

5. Slide the dial indicator to the rear and take the measurement. If the reading of the dial indicator stays the same, the fence is aligned with the miter slot. Otherwise, proceed to the next step for adjustments.

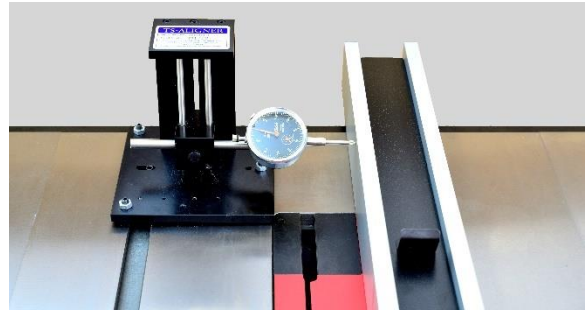

6. Remove the fence from the rail. Adjust the two set screws indicated in the picture in small increments to align the fence.

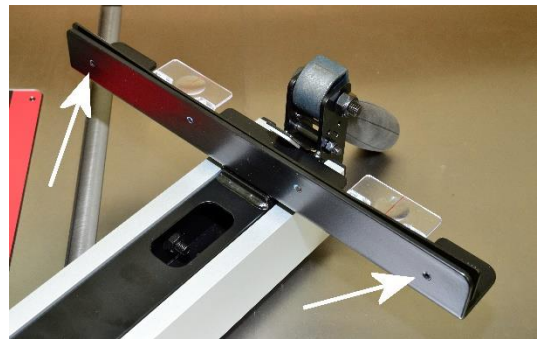

7. Mount the fence and repeat steps [2-5] to check the alignment. Make further adjustments until the fence is aligned with the miter slot, and the fence cam lock pressure is set properly.
8. **NOTE:** Some woodworkers prefer to skew the fence away from the blade to avoid kickback and burning of the cut edge. This is acceptable as long as the offset is less than 1/64". Doing so may impact cut quality.

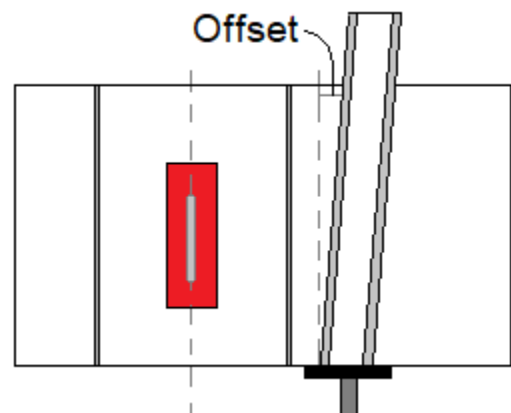

Fence Squareness Adjustment

1. The fence face should be perpendicular to the cast iron table. Check the squareness of the fence with a machinist square.

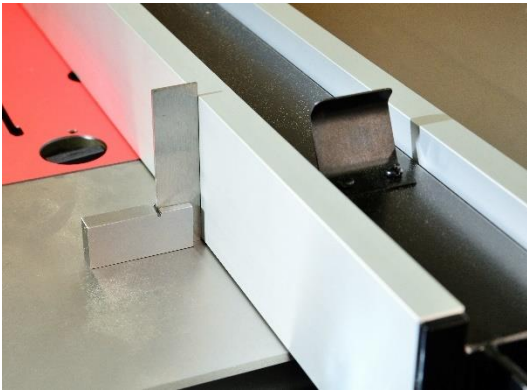

2. To adjust the squareness of the fence, adjust the two nylon set screws on the fence bracket until the fence is perpendicular to the table.

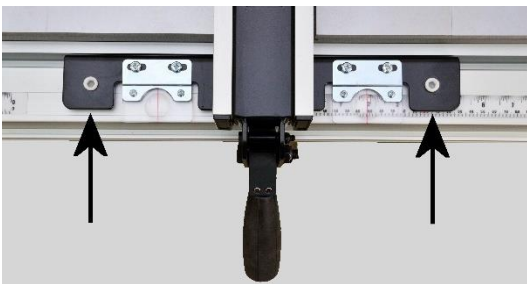

3. After the adjustment, check the height and levelness of the fence. Make sure the fence is elevated approximately 1/16" above the table.

Fence Height Adjustment

1. There should be a 1/16" gap between the fence face and the table. The gap allows the fence to slide freely and not scratch the table. If the gap is too big or if the fence is scratching the table, or if the fence is not level from front to rear, adjustment is needed.
2. To adjust the height of the fence in the front, make the same amount of adjustments on both nylon set screws.

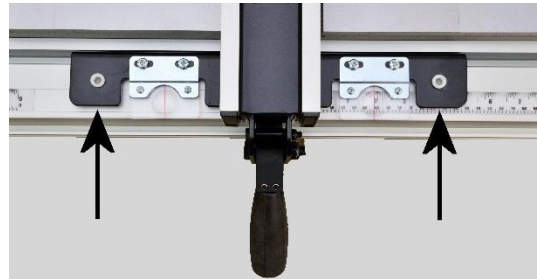

3. To adjust the fence height in the back, loosen the jam nut of the leveling foot. Rotate the leveling foot to set the new height, then retighten the jam nut.

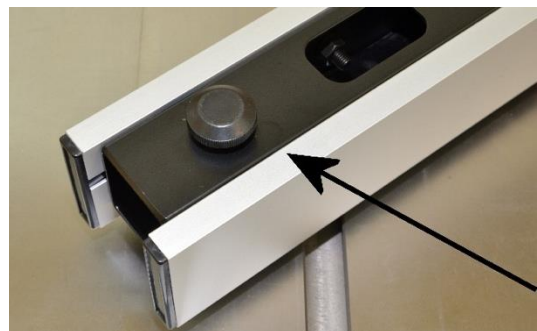

Fence Scale Adjustment

The fence scale indicator should be adjusted if the width-of-cut it indicates does not match the actual cut width.

1. Prepare a piece of scrap plywood with a straight edge for ripping. The scrap piece should be approximately 12" wide and 18" long.
2. Reposition the fence to set the width-of-cut to 10"
3. Follow the safety guidelines and the procedures in "Making a Rip Cut" on page 39 to make the rip cut.
4. Measure the new width of the scrap piece.
5. If the width does not match what is shown on the indicator and the error is greater than 1/8", refer to "Fence Setup" on page 31 to reposition the front rail, then repeat steps [1-4].
6. If the error is less than 1/8", loosen the screws that hold the indicator in place, reposition the indicator, and then retighten the screws.

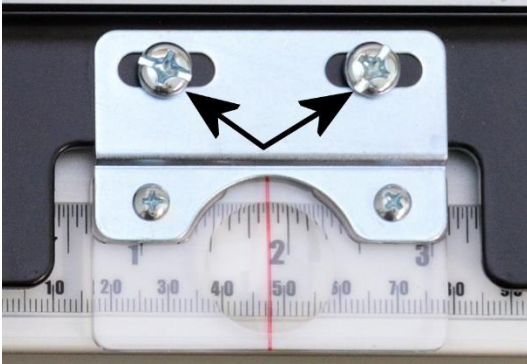

Miter Gauge Angle Indicator Adjustment

If the miter angle indicator has shifted and does not indicate the correct angle, it can be adjusted.

1. **Disconnect the saw from the power source.**
2. Use a square to set the miter angle to 90° against the blade. Tighten the handle to lock the miter gauge.

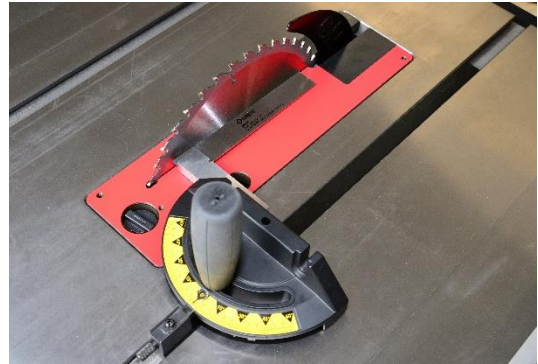

3. Loosen the screw that holds the indicator in place.

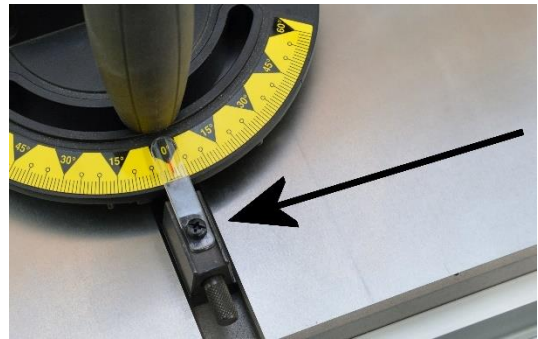

4. Adjust the indicator and tighten the mounting screw.

Miter Gauge Positive Stop Adjustment

There are three positive stops on the miter gauge for quick miter angle adjustments. If a positive stop is not setting the correct angle, it can be adjusted.

1. **Disconnect the saw from the power source.**
2. Pull out the positive stop pin.
3. Use a square or protractor to set the miter angle against the blade. Tighten the handle to lock the miter gauge.
4. Rotate the miter gauge sideways and locate the positive stops. Loosen the jam nut on the positive stop screw.

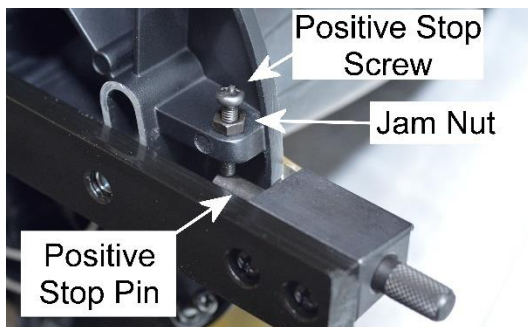

5. Push in the positive stop pin.
6. Adjust the screw by hand until it engages the positive stop pin. Hold the positive screw in place and retighten the jam nut.

IMPORTANT

Do not overtighten the screw as this can bend the positive stop pin and set the angle incorrectly.

Blade Tilt Angle Pointer Adjustment

The blade tilt angle pointer was calibrated at the factory and requires no further adjustments. If the pointer has shifted, it can be adjusted.

1. **Disconnect the saw from the power source.**
2. Set the blade angle to 90° with a digital protractor or a machinist square.



3. Locate the screw that holds the pointer in place. It is behind the blade height handwheel. Removing the handwheel will make it easier to adjust the pointer, and that can be done by removing the handwheel lock knob.



4. Loosen the screw and adjust the pointer.



5. While holding the pointer at the correct position, retighten the screw.
6. Reinstall the blade height handwheel if it was removed.

Blade Angle Positive Stops Adjustments

There are two positive stops for setting the blade angle at 0° and 45°. These positive stops are calibrated at the factory and should not require further adjustments. Please follow these steps in case adjustments are needed.

1. **Disconnect the saw from the power source.**
2. Prepare a pair of 13mm or 1/2" low profile combination wrenches.
3. The positive stop bolts are located on each side of the blade angle gear plate. When setting the blade angle to 0°, it will expose the 45° positive stop bolt on the right.



4. When setting the blade angle to 45°, the 0° positive stop bolt on the left will appear.

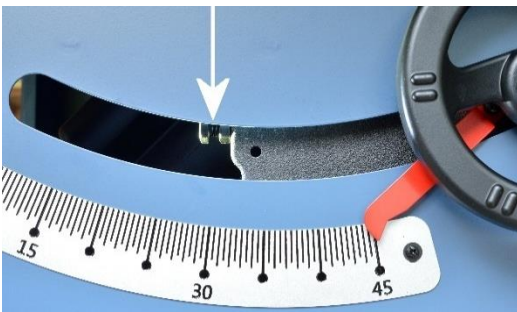

5. Loosen the jam nut. Adjust the positive stop bolt in small increments. Test the adjustment by changing the blade angle until the positive stop is engaged, then check the blade angle.
6. Repeat the previous step until the positive stop bolt is correctly adjusted. When the positive stop is set, hold the positive stop bolt in position and retighten the jam nut.



Spreader/Riving Knife Alignment Adjustment

The spreader/riving knife alignment was calibrated in the factory and should not require further adjustments. If a riving knife or spreader is not aligned with the blade, make sure it is not bent. Follow these steps below if the quick release mechanism needs an adjustment.

1. **Disconnect the saw from the power source.**
2. Remove the table insert.
3. Wear thick leather gloves for this procedure as the calibration work will be done next to the saw blade.



4. Lift the lock lever to remove the blade guard or riving knife.



5. Loosen up the two hex cap screws in the middle of the quick-release mechanism.



6. Adjusting the top/bottom pair of set screws will cause the riving knife to roll left or right along the horizontal axis. Adjusting the left/right pair of set screws will cause the riving knife to rotate along the vertical axis. Make the same amount of small adjustments on the pair of set screws.

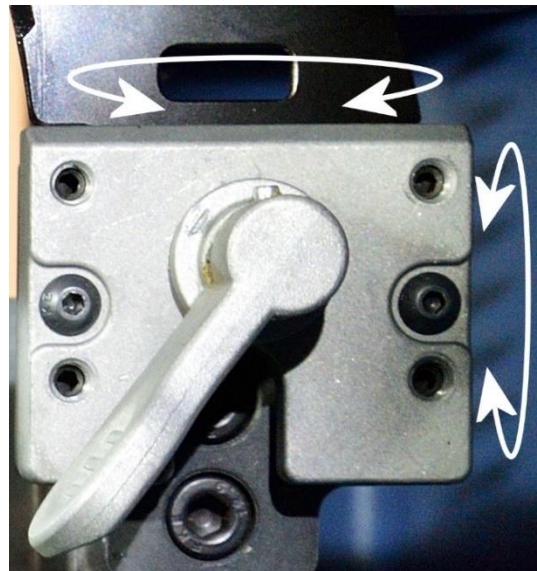

7. Tighten the cap screws and reinstall the riving knife to test the adjustment.
8. Repeat step [5-7] until the riving knife aligns with the blade and stays within the "alignment zone".

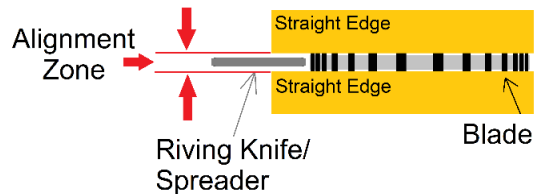

9. Reinstall the table insert and remove gloves before cutting with the table saw.

Maintenance

Routine maintenance keeps your table saw in optimal condition. Please follow the maintenance schedule below, and use the maintenance record worksheet attached to document all tasks completed.

NOTICE: Maintenance schedule may vary for individual users due to different situations and safety requirements.

Task	Frequency
Inspect the power switch, cord, and plug for signs of failure.	Every day before any operation begins.
Inspect saw blade for signs of damage. Replace damaged/dull blades.	Every day before any operation begins.
Clean cast iron table and miter slots, then apply rust protectant.	Weekly
Remove dust accumulated inside the cabinet.	Monthly
Clean trunnion slides, worm gear, and elevation rails. Lubricate with self-cleaning dry lube.	Every 6-12 months.

 WARNING	Disconnect the machine from the power source before performing any maintenance work. After servicing the table saw, remove all tools before restarting the machine. Failure to comply can cause serious injury!
------------------------------------------------------------------------------------------------------	------------------------------------------------------------------------------------------------------------------------------------------------------------------------------------------------------------------------

Cleaning and Lubrication

Clean the trunnion slides, worm gear, and elevation rails every 6-12 months or when it becomes difficult to adjust the saw blade positions.

1. Disconnect the saw from the power source.
2. Remove the motor cover.



3. Remove the table insert.
4. Use a vacuum to remove as much dust inside the cabinet as possible.
5. Remove gum-up grease from these parts:

Front and rear trunnion slides:

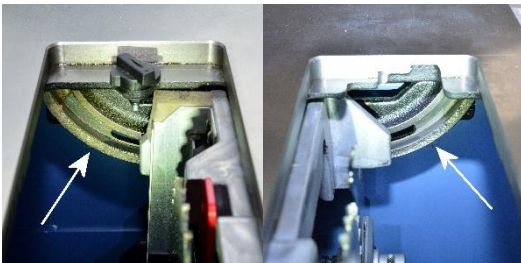

Blade tilt worm gear:



Blade height worm gear and elevation slides:

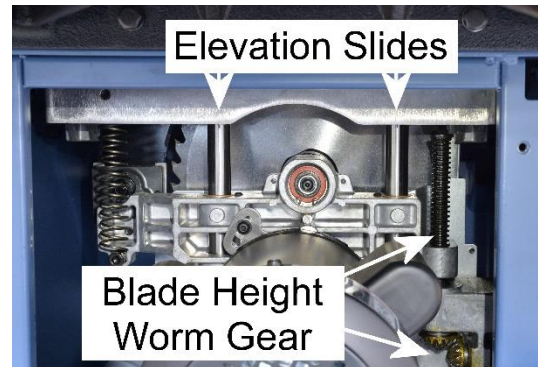

6. Use mineral spirit to remove build-ups that are difficult to remove.
7. Relubricate the components with self-cleaning dry lube, paste wax, or lithium grease.

Belt Tension Adjustment

Belt tension was calibrated at the factory and it should not require adjustments initially. After a long period of use, the poly-v belt may stretch and slip on the pulleys. When that happens the belt needs to be tightened.

1. **Disconnect the saw from the power source.**
2. Remove the motor cover, table insert, and saw blade.
3. Lower the arbor to expose the belt. When pressing on the mid-point of the belt between two pulleys with one finger, the belt should deflect by 1/8" - 1/4".
7. Recheck belt tension. If needed, repeat steps 5 and 6 until the correct belt tension is set.

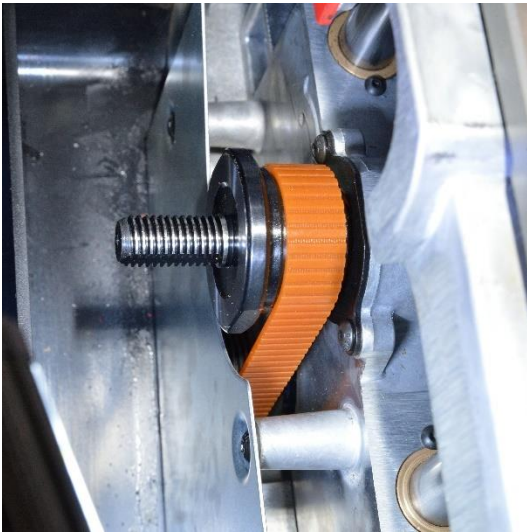

IMPORTANT

Do not over tension the belt as it can accelerate wear and tear of the belt and the bearings.

4. If the belt is cracking or showing any sign of damage, follow the instructions in "Belt Replacement" in the next section instead.
5. Loosen the cap screw (#1) and the motor mounting bolt (#2), so the motor can be raised or lowered by hand. DO NOT remove the fasteners.

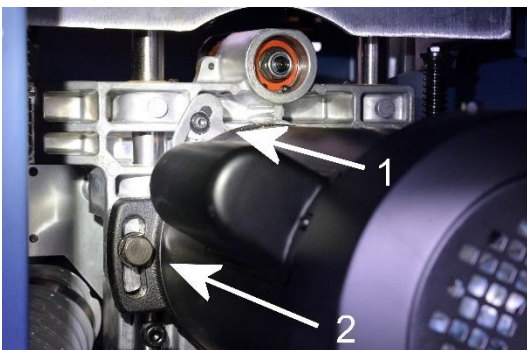

6. Pull the motor down to tighten the belt. At the same time tighten the motor mounting bolt and then the cap screw.

Belt Replacement

1. **Disconnect the saw from the power source.**
2. Remove the motor cover, table insert, and saw blade.
3. Remove the accessory storage plate.



4. Remove the dust shroud. It has five mounting screws.

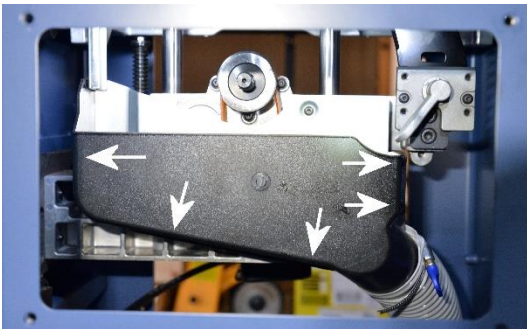

5. Remove the fixing plate that covers the belt and the pulleys.

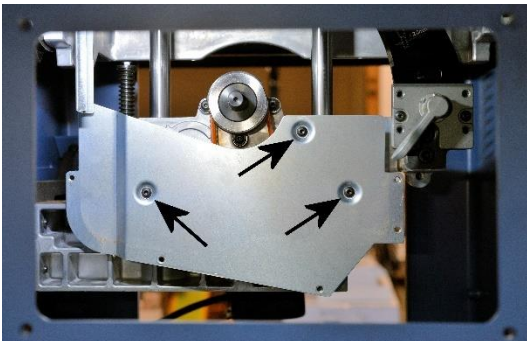

6. Loosen the cap screw (#1) and the motor mounting bolt (#2), so the motor can be raised or lowered by hand. **DO NOT** remove the fasteners.

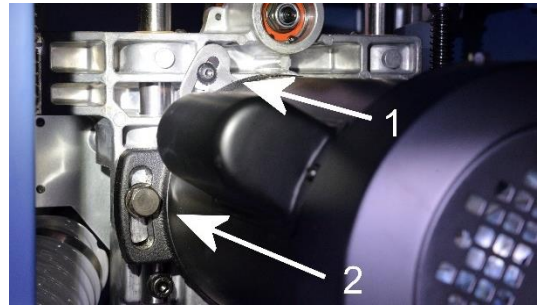

7. Push the motor up to release the belt. Tighten the motor mounting bolt to temporarily hold the motor at the highest position for belt replacement.
8. Walk the belt off from the pulleys, then install the replacement belt. Make sure the poly-v belt sits correctly on the grooves of the pulleys.

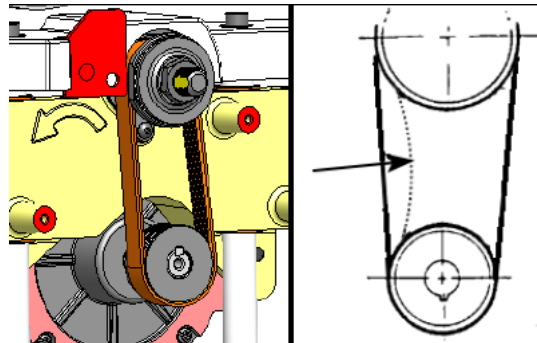

Loosen the motor mounting bolt. Pull the motor down to tighten the belt. At the same time tighten the motor mounting bolt and then the cap screw. The belt should deflect by 1/8" - 1/4" when pressed in between pulleys with a finger.

9. Reinstall the fixing plate, dust shroud, accessories storage plate, motor cover, saw blade, and table insert.
10. Install the blade guard before using the table saw.

IMPORTANT

Do not over tighten the belt as it can accelerate wear and tear of the belt and the bearings.

Troubleshooting

Mechanical / Electrical Issues

Problem	Possible Cause	Solution
Machine will not start	Not connected to a power source.	Make sure the machine is plugged in. Check the electrical panel for a tripped circuit breaker or a blown fuse. Ensure all electrical connections have good contacts.
	The saw was overloaded and thermal protection was triggered.	Wait for at least 5 minutes for the motor to cool down, then press the RESET button on the power switch to reset thermal protection.
	Low voltage / current.	Have a licensed electrician check/repair the power circuit.
	Power switch is locked.	Remove the padlock that disables the switch.
	Faulty switch/motor/capacitor.	Contact customer service for further assistance.
Machine stalls or does not come up to speed	Extension cord is too light or too long.	Use a shorter / heavier cord that meets this machine's electrical requirements.
	Feeding rate is too high.	Reduce feed rate.
	Dull blade or wrong blade for the cut.	Use a sharp, clean blade that is designed for the type of cut.
	Feeding stock with the blade installed backwards.	Reinstall the blade the correct way.
	Ripping crooked stock.	Straighten the fence-facing edge of a workpiece before the rip cut. Avoid ripping unstable stock.
	Stock binding between the blade and the fence.	Ensure both the saw blade and the fence align with the miter slot. Adjust alignment as needed.
	Belt slipping	Clean belt and pulleys. Check/adjust belt tension and make sure the belt is seated properly.
	Motor is not wired properly for the operating voltage.	Use the wiring diagram to properly wire up the motor.
	Motor/capacitor issue.	Contact customer service for further assistance.

Problem	Possible Cause	Solution
Machine stopped during the operation.	Tripped circuit breaker or blown fuse.	Reconnect circuit. Reduce feed pressure.
	Saw was overloaded and thermal protection was triggered.	Wait for at least 5 minutes for the motor to cool down, then press the RESET button on the power switch to reset thermal protection.
Machine vibrates excessively	Machine stands on uneven floors.	Reposition the machine on a flat, level surface. Adjust the leveling feet to keep the machine stable.
	Unbalanced saw blade	Inspect saw blade and replace damaged or warped saw blade.
	Blade was mounted improperly.	Mount saw blade with the right amount of torque. Do not overtighten the arbor nut.
	Worn / loose belt	Check/adjust belt tension. Replace worn/broken belt.
	Improper motor/component mounting.	Check, adjust, and tighten motor/component mounting.
	Motor/arbor bearing issue.	Contact customer service for further assistance.
Blade misaligned with the miter slot	Warped blade.	Replace blade.
	Table misaligned.	Align the miter slot to the blade.
Blade elevation/tilt handwheel binds or is difficult to turn.	Lock knob engaged.	Loosen the lock knob.
	Sawdust/debris build-up inside the cabinet.	Remove dust and debris inside the cabinet. Use dry lube to lubricate the elevation/trunnion gears and slides.
Fence does not clamp securely on the rail.	Nylon pads between the fence and the rails are worn.	Tighten both fence alignment screws and re-adjust fence alignment. Replace nylon pads if they are too worn.
Fence does not glide smoothly on the rails.	Fence alignment screws were not adjusted properly.	Loosen the screws and readjust fence alignment.
	Rails are dirty.	Clean the rails and the nylon pads that shim between the rails and the fence.

Operation Issues

Problem	Possible Cause	Solution
Kickback	Not using any anti-kickback devices.	Whenever possible, use the blade guard or riving knife when cutting with a table saw.
	Making cross cuts with a miter gauge and using a fence to set the length of the cut.	Remove the fence when using a miter gauge for cross cuts.
	Fence is not aligned with the blade.	Adjust fence alignment.
	Riving knife/spreader not aligned with the blade.	Adjust riving knife/spreader alignment.
	Cutting warped/unstable stock.	A warped workpiece should be flattened and have at least one edge straightened before being cut with a table saw. A slightly cupped board should have the cupped side facing down to improve stability when feeding.
	Improper feeding techniques.	Never rotate the workpiece into the back side of the blade when feeding.
Saw dust escape and blow toward the operator.	Dust collection system not operational or underpowered.	Ensure the dust collection system is turned on and has significant suction. Unclog dust shroud and hose, and seal leaks in the dust collection system.
	Blade guard not installed.	Install the blade guard.
Workpiece catches the table insert when feeding.	Table insert is not flush with the table.	Adjust the height of the table insert so all edges are flush with the table.

Quality-Related Issues

Problem	Possible Cause	Solution
Stock burns	Stock binds with the blade.	Adjust alignment between the miter slot, blade, fence, and riving knife/spreader.
	Feeding motion paused during operation.	Maintain feeding speed while cutting the entire length of the stock.
	Feeding speed too low	Increase feeding speed and cut with a sharp, clean blade.
	Dull blade or wrong blade for the cut.	Use a sharp, clean blade that is designed for the type of cut.
	Warped/unstable stock	Straighten the fence-facing edge of a workpiece before the rip cut. Avoid ripping unstable stock.
Unexpected width of cut.	Reading the wrong scale pointer on the fence.	Use the scale pointer on the right when ripping on the right hand side of the blade, and vice versa.
	The fence scale pointer is not adjusted.	Adjust the scale pointer.
The edge of a rip cut is not squared.	Incorrect blade tilt angle.	Adjust blade angle.
	Blade tilt angle pointer misaligned.	Adjust blade tilt angle pointer.
	90° positive stop out of adjustment.	Adjust 90° positive stop.
	Fence is not vertically in parallel with the blade.	Adjust fence squareness.
Saw marks on the cut edge	Warped/dirty/worn blade.	Use a balanced, clean, and sharp blade for cutting.
	Fence is not aligned with the blade.	Adjust fence alignment with blade.
	Miter slot is not aligned with the blade.	Adjust miter slot alignment with blade.
Cut edge splintering when making cross cuts.	Dull blade	Replace the dull/dirty blade with a clean, sharp blade.
	Saw blade has too few teeth or the feed rate is too high.	Use a crosscut saw blade and/or reduce feed rate.

Wiring Diagrams

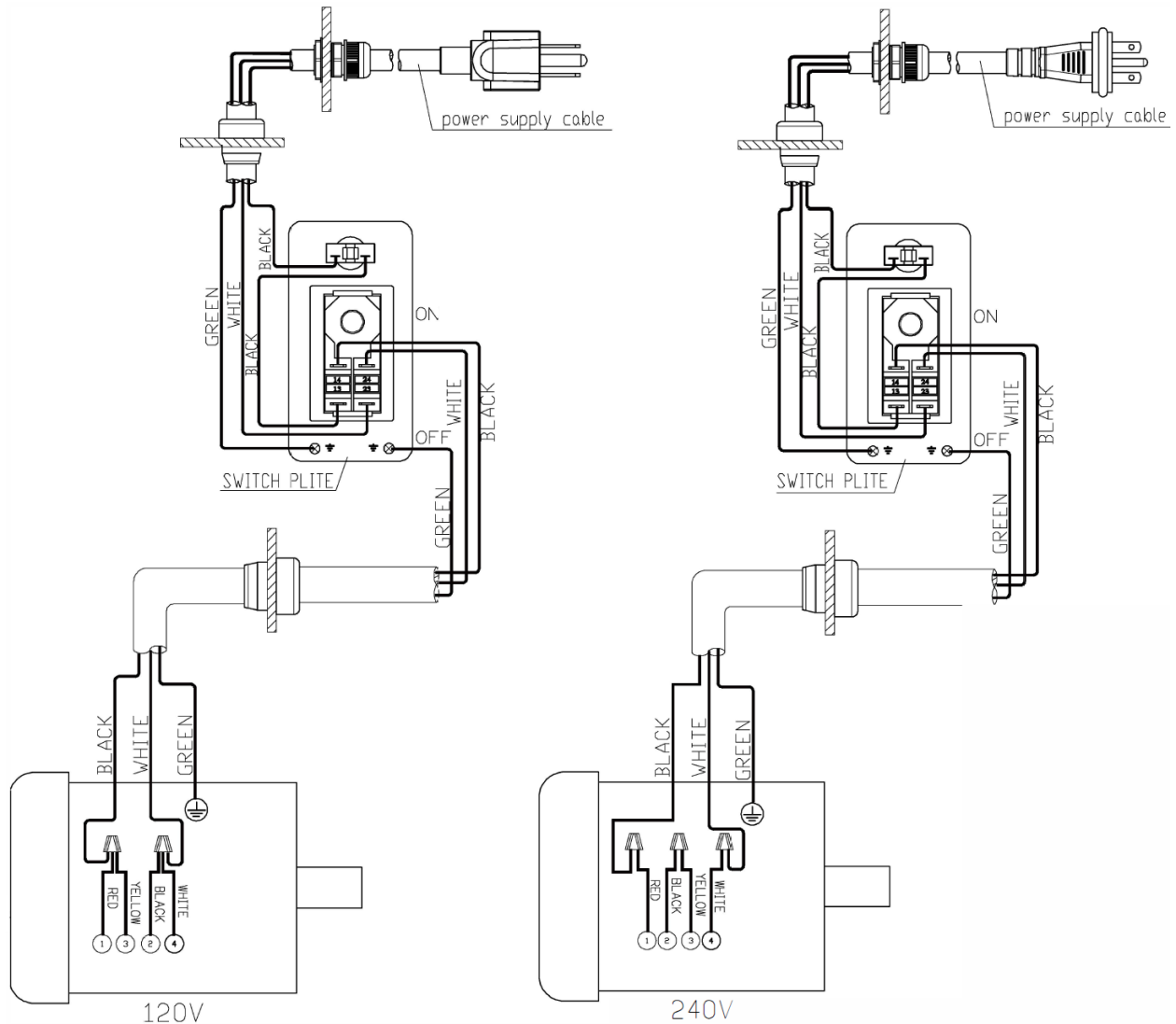

WARNING  The power switch must be replaced when wiring the motor for a 240V power source. Please order part #937910-001 before rewiring. Not using the correct power switch can result in electrocution and machine damage. Using an incorrect power switch also creates a fire hazard.

DANGER  Deenergize the electrical circuit before touching any enclosed, electrified parts. Touching an electrified part WILL result in serious personal injury or death.

WARNING  Faulty electrical work can cause electrocution and is a fire hazard. All electrical work must be completed by a licensed electrician and must meet the local electrical code in your area or the warranty is void.

Parts List

Table and Cabinet

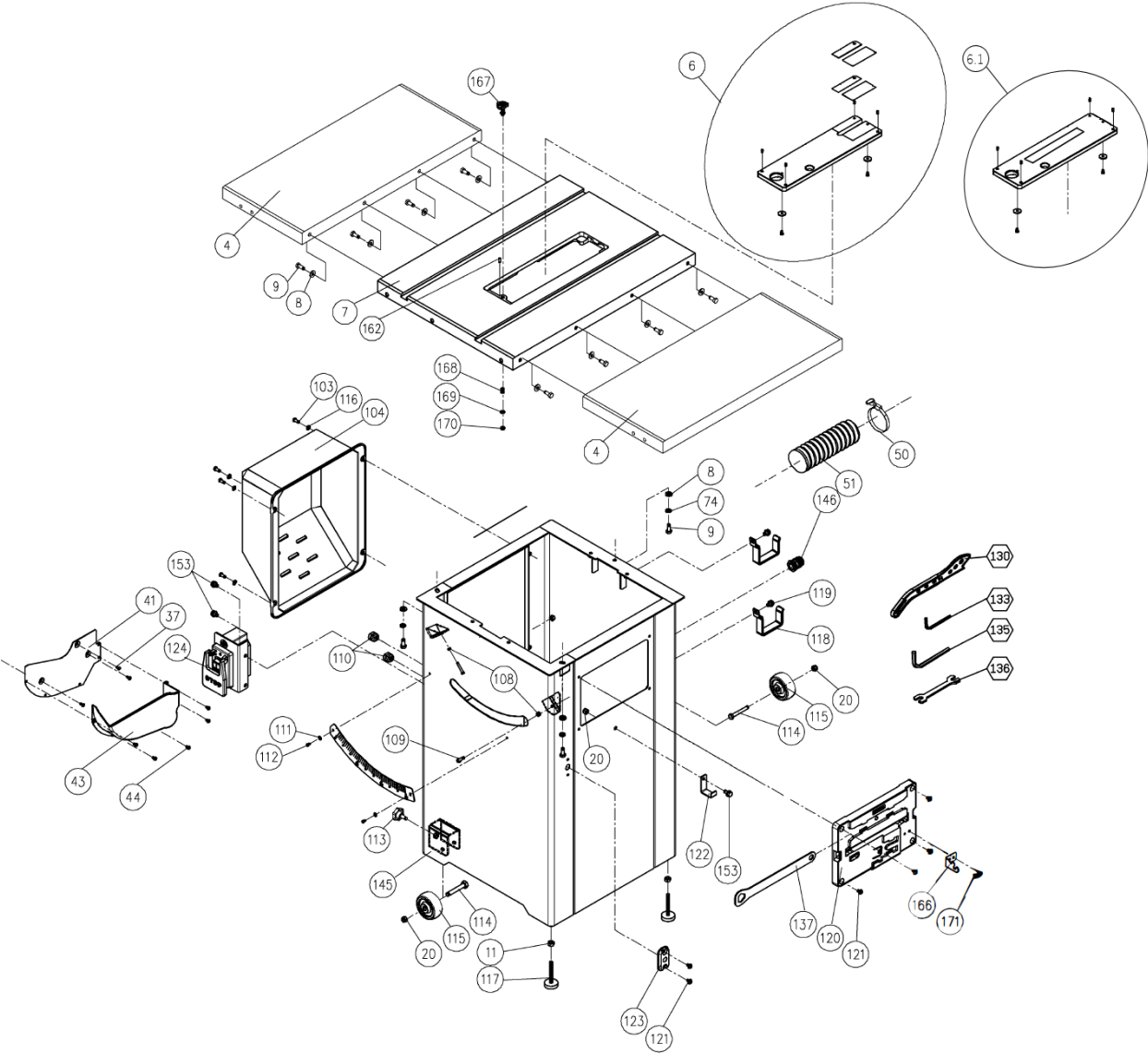

Motor and Trunnion Assembly

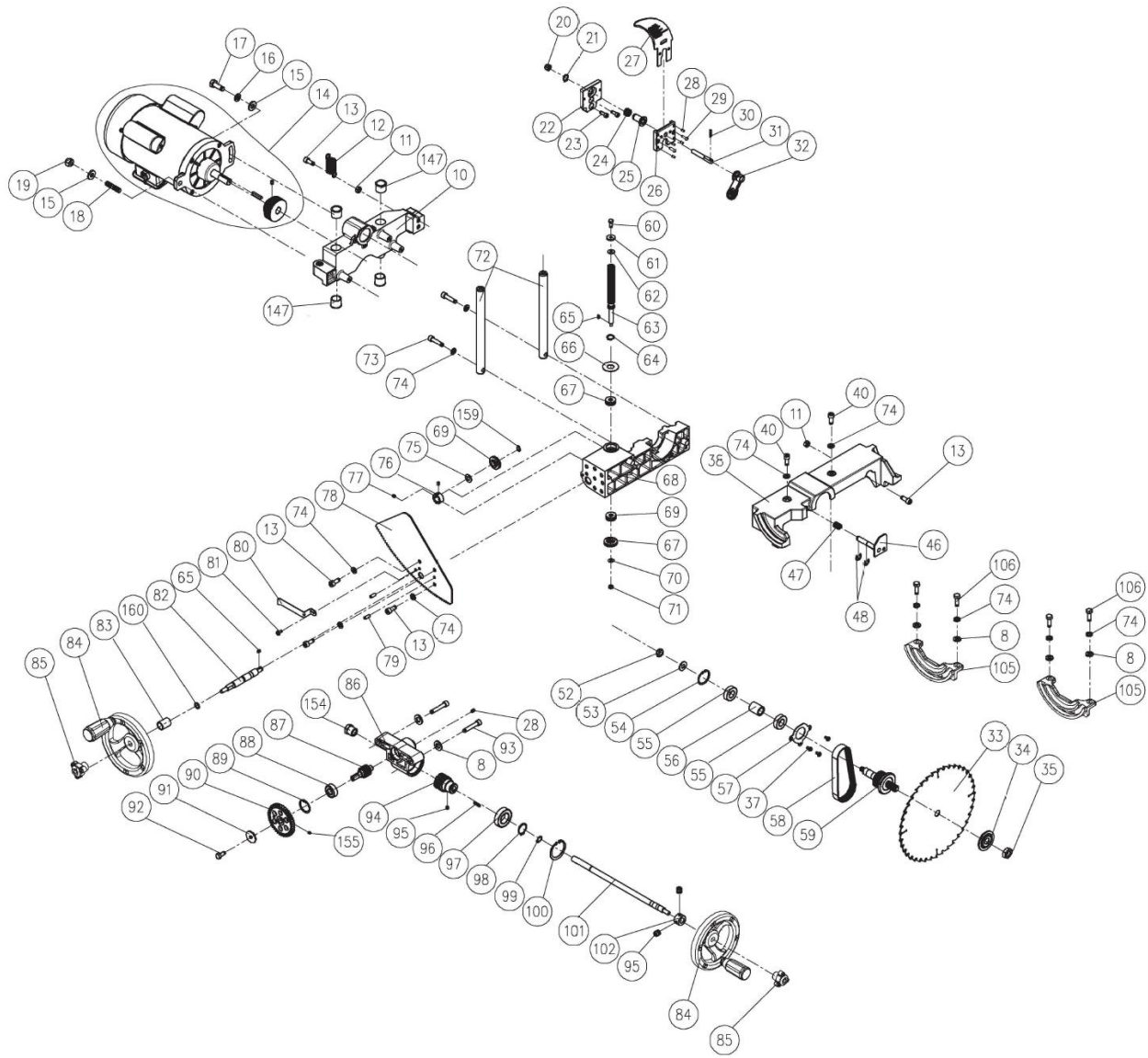

Rip Fence Assembly

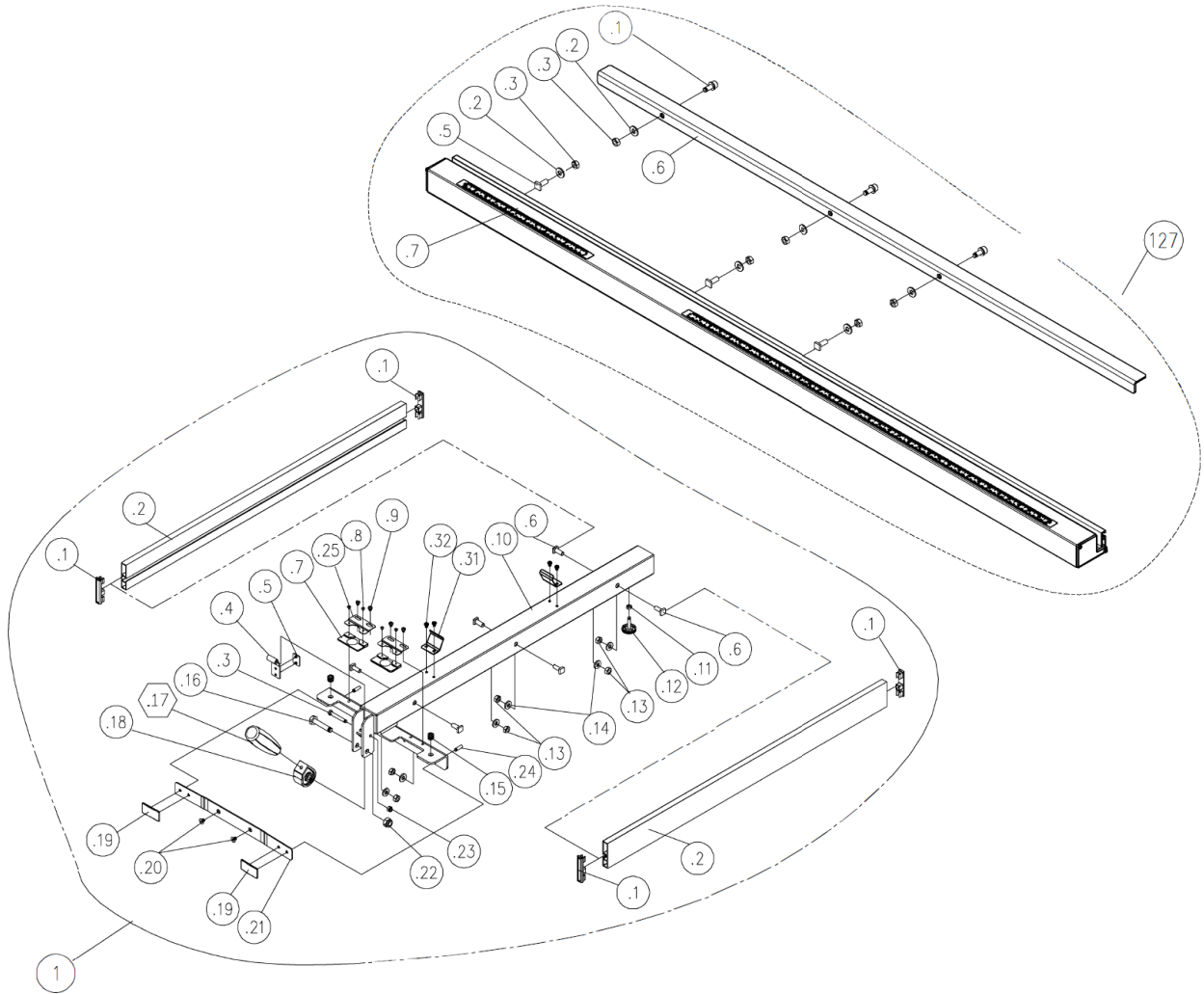

Right Table Assembly (Stock #10040.102)

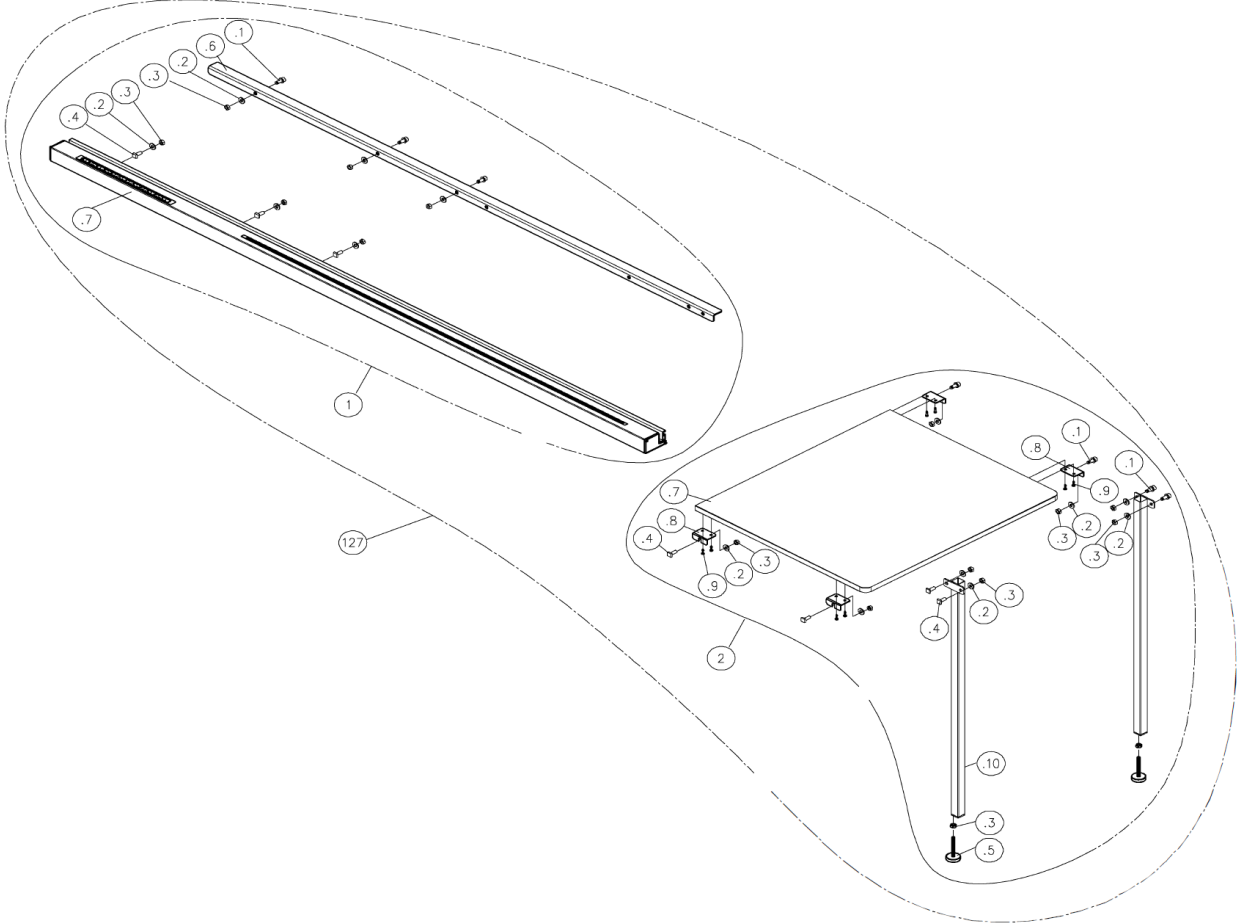

Blade Guard and Miter Gauge

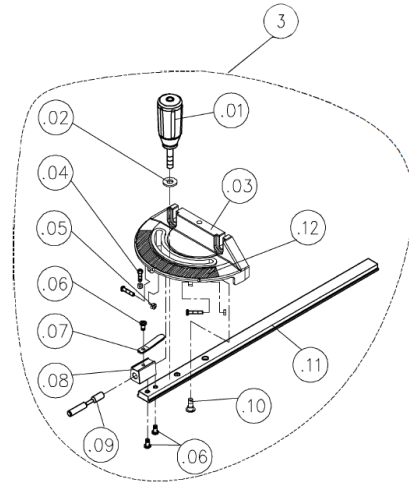
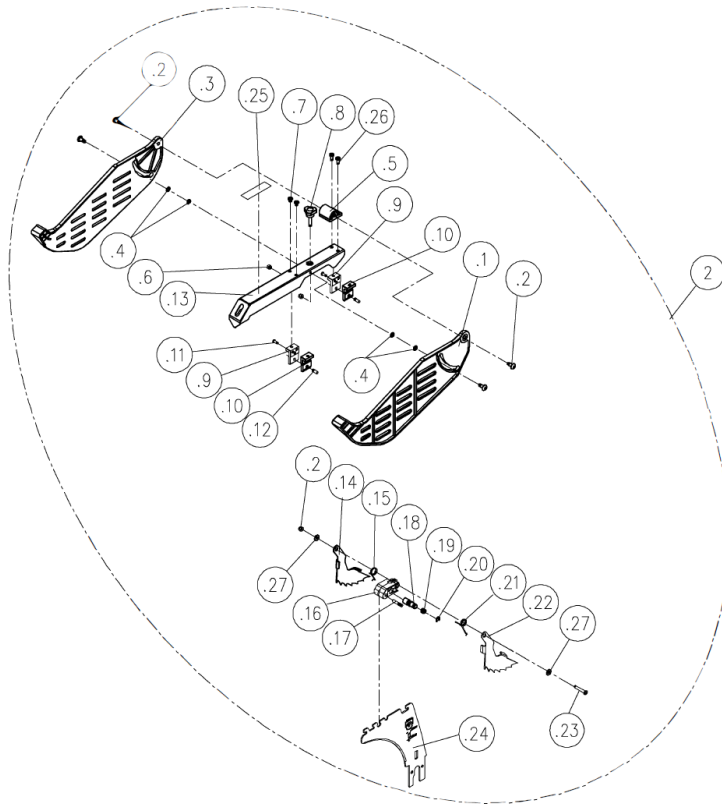

Index	Part Number	Descriptions	Specifications	QTY
1	923136-000	Rip Fence Assembly		1
1.1	250483-615	End Cap		4
1.2	310100-909	Fence Face		2
1.3	000002-308	Hex Screw	M6*1.0P*45	1
1.4	171993-904	Bracket		1
1.5	250602-621	Friction Plate		1
1.6	048701-101	Square Bolt	M8*1.25P*20	6
1.7	250799-620	Pointer		2
1.8	001101-205	Round Head Tapping Screw	M3*1.06P*6	4
1.9	000304-210	Pan Head Screw	M6*1.0P*6	4
1.10	173142-308	Fence Body		1
1.11	008005-100	Hex Nut	M6*1.0P(10B*5H)	1
1.12	250587-615	Friction Pad		1
1.13	008006-100	Hex Nut	M8*1.25P(13B*6.5H)	6
1.14	006001-049	Flat Washer	8.5*16*2t	6
1.15	250472-621	Plastic Set Screw	M12*1.75P	2
1.16	000004-306	Hex Screw	M10*1.5P*50	1
1.17	230301-615	Handle		1
1.18	922141-000	Compress Cam Assembly		1
1.19	250471-621	Friction Plate		2
1.20	002103-103	Flat Head Screw	M6*1.0P*8	2
1.21	172341-904	Bracket for Friction Plate		1
1.22	008308-100	Lock Nut	M10*1.5P(17B*12H)	1
1.23	008304-100	Lock Nut	M6*1.0P(10B*7H)	1
1.24	001902-109	Set Screw	M6*1.0P*6	2
1.25	172847-905	Bracket for Pointer		2
1.31	270007-901	Spring Plate		2
1.32	000302-101	Pan Head Screw	M4*0.7P*6	4
2	924395-000	Blade Guard Assembly		1
2.1	251246-000	Right Cover		1
2.2	290073-905	Shoulder Shaft		4
2.3	251247-000	Left Cover		1
2.4	043317-000	O-Ring	P006	4
2.5	130365-903	Clamper Support		1
2.6	008302-100	Lock Nut	M5*0.8P(8B*6H)	2
2.7	000303-101	Pan Head Screw	M5*0.8P*6	2
2.8	230336-615	Knob		1
2.9	130270-903	Rod Bracket -Left		2

Index	Part Number	Descriptions	Specifications	QTY
2.10	130271-903	Rod Bracket -Right		2
2.11	000302-103	Pan Head Screw	M4*0.7P*10	2
2.12	360960-901	Pin		2
2.13	171154-904	Blade Guard Body		1
2.14	171378-904	Anti-Kick Finger -Left		1
2.15	280162-901	Spring		1
2.16	090149-910	Block		1
2.17	360864-000	Pin		1
2.18	360865-901	Spreader Shaft		1
2.19	280160-901	Spring		1
2.20	010204-000	Retaining Ring	ETW-7	1
2.21	280163-901	Spring		1
2.22	171379-904	Anti-Kick Finger -Right		1
2.23	000303-110	Pan Head Screw	M5*0.8P*30	1
2.24	174397-904	Spreader		1
2.25	573543-000	Warning Label		1
2.26	000303-104	Pan Head Screw	M5*0.8P*12	2
2.27	006001-012	Flat Washer	5.3*12*1.0t	2
3	924506-001	Miter Gauge Assembly		1
3.1	920720-000	Miter Gauge Handle Assembly		1
3.2	006001-053	Flat Washer	8.5*19*2.0t	1
3.3	090109-008	Miter gauge body		1
3.4	000302-108	Pan Head Screw	M4*0.7P*20	3
3.5	008002-100	Hex Nut	M4*0.7P(7B*3.2H)	3
3.6	000303-103	Pan Head Screw	M5*0.8P*10	3
3.7	250226-620	Pointer		1
3.8	130057-903	Spacer		1
3.9	360447-901	Angle Set Bar		1
3.10	290023-901	Shoulder Screw		1
3.11	310496-911	Slot Bar		1
3.12	571614-000	Miter Scale		1
4	051386-000	Extension Wing		2
6	924397-001	Zero Clearance Insert		1
6.1	924531-001	Pre-cut Dado Insert (Manufactured between 2017-2019)		1
	A-10040.A005	Zero-clearance Dado Insert (2019 and after)		1
7	051368-000	Table		1
8	006001-049	Flat Washer	8.5*16*2.0t	19
9	000003-104	Hex Screw	M8*1.25P*20	11
10	090322-000	Up-down Bracket		1
11	008006-100	Hex Nut	M8*1.25P(13B*6.5H)	5
12	280266-901	Spring		1
13	000104-106	Cap Screw	M8*1.25P*20	5

Index	Part Number	Descriptions	Specifications	QTY
14	901138-000	Motor w/Pulley	1.75HP*120V/240V*1PH Prewired 120V	1
15	006001-069	Flat Washer	10*20*3.0t	1
16	006307-100	Spring Washer	10.2*18.5	1
17	000004-103	Hex Screw	M10*1.5P*30	1
18	360863-901	Motor Fixing Shaft		1
19	008308-100	Lock Nut	M10*1.5P(17B*12H)	1
20	008306-100	Lock Nut	M8*1.25P(13B*9H)	4
21	010005-000	Retaining Ring	STW-14	1
22	130359-903	Bracket for Riving Knife		1
23	000104-104	Cap Screw	M8*1.25P*16	6
24	280259-901	Spring		1
25	130363-903	Bushing		1
26	130360-903	Block		1
27	174396-904	Riving Knife		1
28	001902-110	Set Lock Screw	M6*1.0P*8	5
29	000804-106	Round Head Screw	M5*0.8P*16	2
30	361251-905	Pin		1
31	361250-901	Fixing Knob		1
32	110071-000	Lock Handle		1
33	390017-000	Saw Blade	10"*40T	1
34	174399-901	Saw Blade Clamp		1
35	380205-901	Nut	5/8"	1
37	002503-101	Round Head Socket Lock Screw	M5*0.8P*12	6
38	090323-000	Upper Trunnion		1
40	002601-102	Locking Cap Screw	M8*1.25P*20	2
41	174371-000	Fixing Plate		1
43	251277-615	Dust Hood		1
44	000303-202	Pan Head Screw	M5*0.8P*8	5
46	174325-156	Arbor Lock Handle		1
47	280260-901	Spring		1
48	010206-000	Retaining Ring		2
50	042608-000	Clamp	60-80mm(I.D.)	1
51	042615-000	Dust Hose	2.5"(I.D.)*800mm	1
52	008316-200	Lock Nut	M10*1.5P(17B*8H)	1
53	006001-076	Flat Washer	10.3*23*2.0t	1
54	010103-000	Retaining Ring	RTW-35	1
55	030211-002	Ball Bearing	6003	2
56	190270-901	Spacer		1
57	174305-901	Fixed Plate		1

Index	Part Number	Descriptions	Specifications	QTY
58	014354-000	Poly V-Belt	135J7	1
59	381281-902	Arbor		1
60	000002-103	Hex Screw	M6*1.0P*16	1
61	006001-020	Flat Washer	6.2*20*3.0t	1
62	006007-114	Flat Washer	6.4*16*1.6t	1
63	361245-901	Lead Screw		1
64	010007-000	Retaining Ring	STW-16	1
65	012002-003	Key	4*4*8	2
66	174324-000	Washer		1
67	031011-001	Bearing	51100	2
68	090324-000	Trunnion		1
69	130257-000	Bevel Gear		2
70	006001-025	Flat Washer	6.4*16*1.0t	2
71	008317-300	Lock Nut	M6*1.0P(10B*5H)	2
72	361246-000	Column		2
73	000104-111	Cap Screw	M8*1.25P*35	2
74	006305-100	Spring Washer	8.2*15.4	14
75	006001-078	Flat Washer	10.5*19*1.5t	1
76	190273-901	Bushing		1
77	000202-101	Set Screw	M5*0.8P*5	2
78	174309-901	Gear Plate		1
79	011004-101	Spring Pin	6*16	2
80	174322-156	Pointer		1
81	002402-101	Round Head Lock Screw w/Washer	M5*0.8P*12/5*10.5*1.0t	1
82	361268-901	Shaft		1
83	251276-615	Bushing		1
84	920715-000	Handwheel Assembly		2
85	920703-000	Fixing Knob		2
86	090326-000	Worm Gear Box		1
87	320395-901	Worm Shaft		1
88	030106-001	Ball Bearing	6201	1
89	010102-000	Retaining Ring	RTW-32	1
90	130361-000	Gear		1
91	006001-127	Flat Washer	5.5*22*2.0t	1
92	000001-109	Hex Screw	M5*0.8P*12	1
93	000104-113	Cap Screw	M8*1.25P*45	2
94	320394-901	Worm Shaft		1
95	001902-109	Set Screw	M6*1.0P*6	3
96	012002-007	Key	4*4*20	1
97	030104-001	Ball Bearing	6005	1

Index	Part Number	Descriptions	Specifications	QTY
98	010011-000	Retaining Ring	STW-25	1
99	010004-000	Retaining Ring	STW-13	1
100	010107-000	Retaining Ring	RTW-47	1
101	361249-901	Shaft		1
102	360734-901	Bushing		1
103	000304-107	Pan Head Screw	M6*1.0P*16	4
104	251239-615	Motor Cover		1
105	051135-000	Trunnion Support		2
106	000003-105	Hex Screw	M8*1.25P*25	4
108	008005-100	Hex Nut	M6*1.0P(10B*5H)	2
109	000002-105	Hex Screw	M6*1.0P*25	2
110	020016-000	Strain Relief	SR-6R1	1
111	006001-001	Flat Washer	4.3*10*1.0t	2
112	000302-102	Pan Head Screw	M4*0.7P*8	2
113	004001-101	Knob	5/16"-18NC*3/4"	2
114	000003-316	Hex Screw	M8*1.25P*60	2
115	250399-615	Wheel		2
116	006001-022	Flat Washer	6.3*13*1.0t	4
117	230041-000	Leveling Foot		2
118	170541-904	Fence Bracket		2
119	049201-102	Hex Screw w/Washer	M8*1.25P*12/(13B*6.5H)	2
120	251251-615	Storage Plate		1
121	001603-102	Round Head Screw w/Washer	M6*1.0P*10/6*13.2*1.0t	6
122	170965-904	Fix Plate		1
123	250407-615	Worm Shaft Bracket		1
124	937911-001	Magnetic Switch Assembly	1.75HP 120V CSA	1
124	937910-001	Magnetic Switch Assembly	1.75 HP 240V CSA	1
127	924465-001	36" Rail Assembly	36"	1
127.1	001803-102	Cap Screw w/ Spring Washer	M8*1.25P*20/8.2*15.4	3
127.2	006001-049	Flat Washer	8.5*16*2.0t	6
127.3	008006-100	Hex Nut	M8*1.25P(13B*6.5H)	6
127.5	048701-101	Square Bolt	M8*1.25P*20	1
127.6	174393-308	Rear Rail		1
127.7	924509-001	Front Rail w/Scales & End Caps	12" L / 36" R	1
127	924533-001	52" Rail with Right Table Assembly		1
127-1	924534-001	52" Rail Assembly		1
127-1.1	001803-102	Cap Screw w/ Spring Washer	M8*1.25P*20/8.2*15.4	3
127-1.2	006001-049	Flat Washer	8.5*16*2.0t	7
127-1.3	008006-100	Hex Nut	M8*1.25P(13B*6.5H)	7
127-1.4	048701-101	Square Bolt	M8*1.25P*20	4

Index	Part Number	Descriptions	Specifications	QTY
127-1.6	174394-308	Rear rail		1
127-1.7	924510-001	Front Rail w/Scales & End Caps	12" L / 52" R	1
127-2	924532-001	Right Table Assembly		1
127-2.1	001803-102	Cap Screw w/ Spring Washer	M8*1.25P*20/8.2*15.4	4
127-2.2	006001-049	Flat Washer	8.5*16*2.0t	8
127-2.3	008006-100	Hex Nut	M8*1.25P(13B*6.5H)	10
127-2.4	048701-101	Square Bolt	M8*1.25P*20	4
127-2.5	230041-000	Leveling Foot		2
127-2.7	440077-000	Table		1
127-2.8	173139-902	Brace		4
127-2.9	230086-901	Self-Tapping Screw		8
127-2.10	190205-308	Steel Legs		2
130	230334-615	Push Stick		1
133	040002-000	Hex. Wrench	2.5mm	1
135	040006-000	Hex. Wrench	6mm	1
136	040203-000	Open Wrench	11*13	1
137	174315-904	Arbor Wrench		1
145	174478-000	Stand		1
146	021311-000	Strain Relief	PGA13.5-11B	1
147	130367-000	Bushing		4
153	049201-101	Hex Screw w/Washer	M8*1.25P*16/(13B*6.5 H)	3
154	130368-903	Adjusting Bushing		1
155	001901-101	Set Screw	M5*0.8P*5	1
159	010001-000	Retaining Ring	STW-10	1
160	043322-000	O-Ring	P11	1
162	011001-103	Spring Pin	3*10	1
166	174398-904	Hook		1
167	251243-615	Knob		1
168	280179-000	Spring		1
169	006001-010	Flat Washer	5.2*12*1.5t	1
170	008302-100	Lock Nut	M5*0.8P(8B*6H)	1
171	001104-703	Round Head Screw	M5*2.12P*12	2

Warranty and Service

Oliver Machinery makes every effort to assure that its equipment meets the highest possible standards of quality and durability. All products sold by Oliver Machinery are warranted to the original purchaser to be free from defects for a period of two (2) years on all parts excluding electronics and motors which are warranted for one (1) year from the date of shipment. Oliver Machinery's obligation under this warranty shall be exclusively limited to repairing or replacing products or parts or components, at its sole option, determined by Oliver Machinery to be defective. Oliver Machinery shall not be required to provide other form of indemnity or compensation including but not limited to compensatory damages.

This warranty is non-transferable and is only extended to the original purchaser from an authorized distributor.

This warranty does not apply to defects due to direct or indirect misuse, abuse, negligence, accidents, unauthorized repairs, alternation outside our facilities, lack of maintenance, acts of nature, or items that would normally be consumed or require replacement due to normal wear and tear.

OTHER TERMS

To obtain and exercise the warranty right, please call 800-559-5065 or fill out warranty request form online at www.olivermachinery.net.

Warranty parts are shipped via Parcel or Ground. Additional charges will occur and charge to customers if express shipping is required.

DISCLAIMER

Under no circumstances shall Oliver Machinery be liable for death, personal or property injury, or damages arising from the use of its products.

Oliver Machinery reserves the right to make changes without prior notice to its products to improve function or performance or design.

FOR MORE INFORMATION

If you need assistance or have questions beyond what is covered in the scope of this warranty information, please call 800-559-5065 or email us at info@olivermachinery.net.



Oliver Machinery is always adding new Industrial Woodworking products to the line.

For complete, up-to-date product information, visit us online at:

WWW.OLIVERMACHINERY.NET

or call toll free 1-800-559-5065

**** SAVE THIS MANUAL FOR FUTURE REFERENCE. ****