



Oliver Machinery Zero Clearance Insert Instructions

WARNING

- Disconnect the saw from its power source before removing, installing and fitting insert.
- Always wear proper eye protection.
- Do not tilt the blade when it is in the insert. Machine damage and serious injury may occur.
- A separate insert must be used for cutting the insert at a different angle.
- Read and fully understand all safety instructions before operation.

 **California Proposition 65 Warning**
This product contains chemicals known to the State of California to cause cancer, and birth defect or other reproductive harm. For more information, visit www.p65warnings.ca.gov.

Content of Zero Clearance Insert

Check the content of the zero clearance insert package. It comes with five (5) set lock screws attached as in **FIG. 1**. If any set lock screws are missing, contact Oliver Machinery at 800-559-5065 or info@olivermachinery.net.

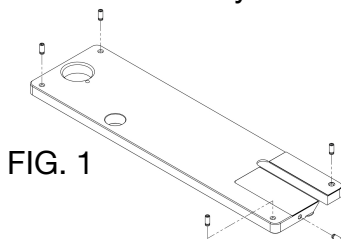

A. Installing and Fitting

Before installing and fitting, make sure the throat cavity is clean without any dust or debris to prevent bent or uneven alignment.

STEP 1: Lower the blade completely.
STEP 2: Place the insert in the throat opening sitting the back end first as shown in **FIG. 2**.

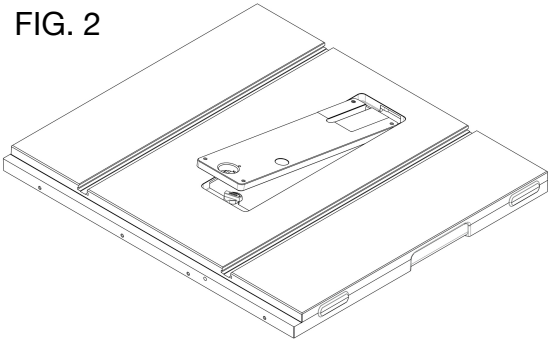

STEP 3: Slide the insert lengthwise, if there is front to back play, adjust the set lock screw on the back edge using 2.5mm hex. L wrench as in **FIG. 3**.

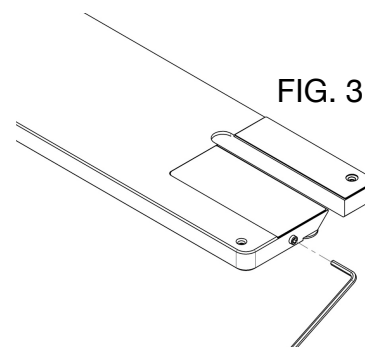

STEP 4: After the insert is fit and tight, turn the insert lock knob to position and lock the insert with the saw as in **FIG. 4**.

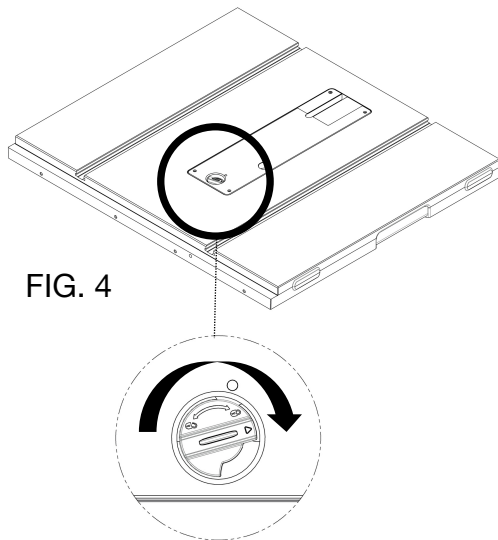

STEP 5: Adjust two (2) leveling set lock screws on the front to be 0 to 0.05mm lower than the table as in **FIG. 5** while adjust two (2) leveling set lock screws on the back to be 0 to 0.5mm higher than the table.

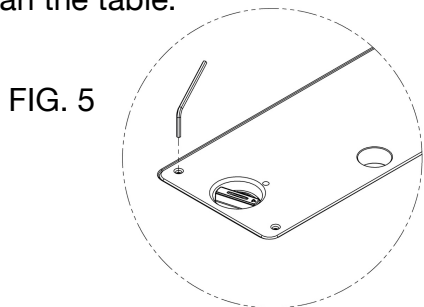

STEP 6: Make sure the insert is fitted properly, and the blade is clear and not touching the insert.

STEP 7: Re-connect the saw to the power. Turn the saw on and slowly raise the blade to its maximum cutting height to cut through the insert.

WARNING: KEEP HANDS OFF TABLE TOP, STAY CLEAR AND WEAR EYE PROTECTION.

NOTE: This table saw is equipped with an insert lock as in **FIG. 4** and an anti-lift washer as in **FIG. 6**. Therefore, clamping a board to the table ends on the top of the zero-clearance insert is not required.

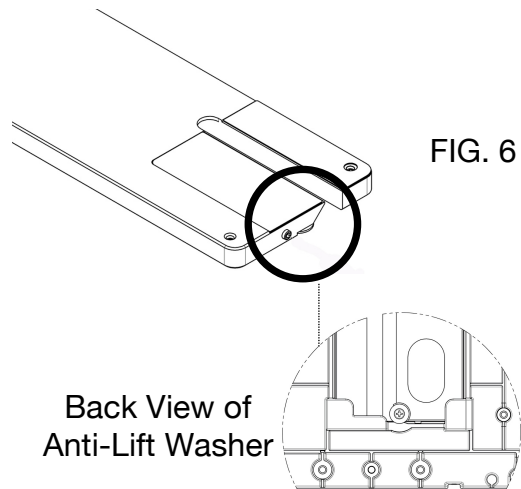

STEP 8: Lower the blade, and turn off the saw until it comes to a complete stop. The Zero clearance insert is ready for use.

NOTE: Use the same procedures for Zero Clearance Dado Inserts, but use additional caution due to excessive material being removed from the insert.

QUESTIONS?

CALL US at 1-800-559-5065.