



"Every User
Is a Booster"

"Oliver" No. 21

Pattern Makers' Combination Lathe

Very Versatile
Very Powerful
Easy to Operate

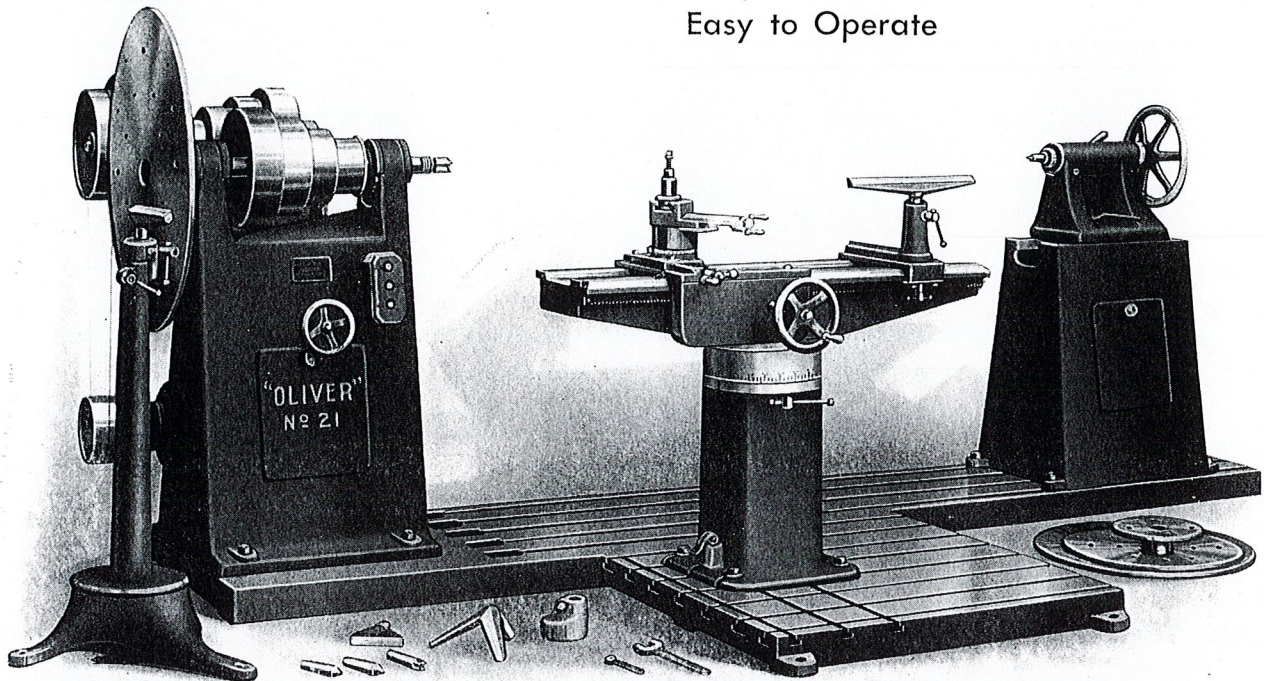

No. 21-AC "OLIVER" COMBINATION PATTERN LATHE. View Showing Tail Stock and Extension Sole Plate. Extended Sole Plate for increased capacity either for lengths or to facilitate the use of tool post around pit on outside face plate at additional cost. Note—Rest Holder shown on right end of carriage is not regular equipment.

A Few Users of this Lathe

Amer. Brake Shoe & Fdy., Chicago Hts., Ill.
Amer. Hoist and Derrick Co., St. Paul, Minn.
American Locomotive Co., Chester, Pa.
American Locomotive Wks., Dunkirk, N. Y.
American Steel & Wire Co., So. Sharon, Pa.
Babcock & Wilcox, Barberton, Ohio
Dessemmer Gas Engine Co., Grove City, Pa.
DeLaval Steam Turbine Co., Trenton, N. J.
Emerson Steam Pump Wks., Alexandria, La.
Goodyear Tire & Rubber Co., Akron, Ohio
Kelley Springfield Tire Co., Cumberland, Md.
Link Belt Company, Chicago, Ill.
Nash Engineering Co., So. Norfolk, Conn.
Niles Bement Pond Co., New York, N. Y.
Norfolk & Western R. R., Roanoke, Va.
Otis Elevator Co., Yonkers, N. Y.
Penna. Steel Cast. & Mach. Co., Chester, Pa.
Railroad Supply Co., Chicago, Ill.
U. S. Navy Department, Washington, D. C.

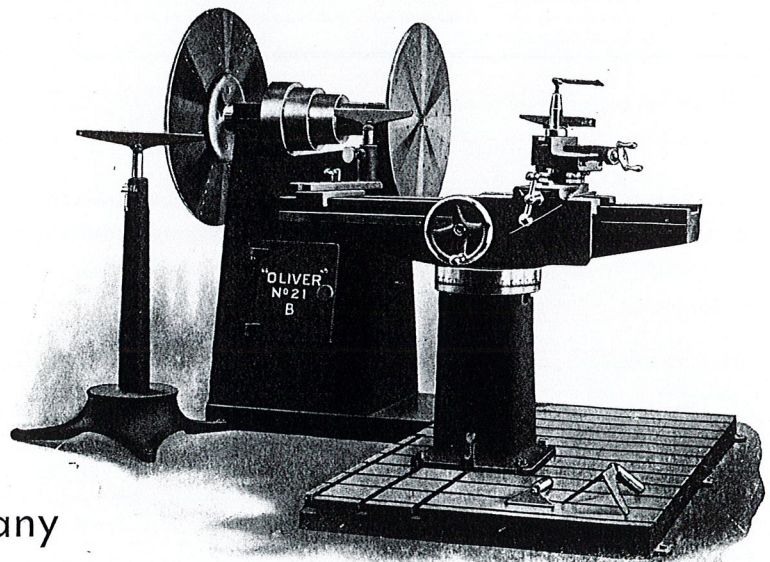

Manufactured by

Oliver Machinery Company

Grand Rapids, Michigan, U. S. A.

BRANCH SALES OFFICES:

New York, Cleveland, Detroit, Indianapolis, Chicago, St. Louis,
Minneapolis, Denver, Salt Lake City, Seattle, Portland,
San Francisco, Los Angeles.

No. 21-BC Lathe without Tailstock, extension sole plate, and centers.

OLIVER MACHINERY COMPANY  GRAND RAPIDS, MICHIGAN, U.S.A.

“OLIVER” NO. 21 PATTERN MAKERS’ COMBINATION LATHE

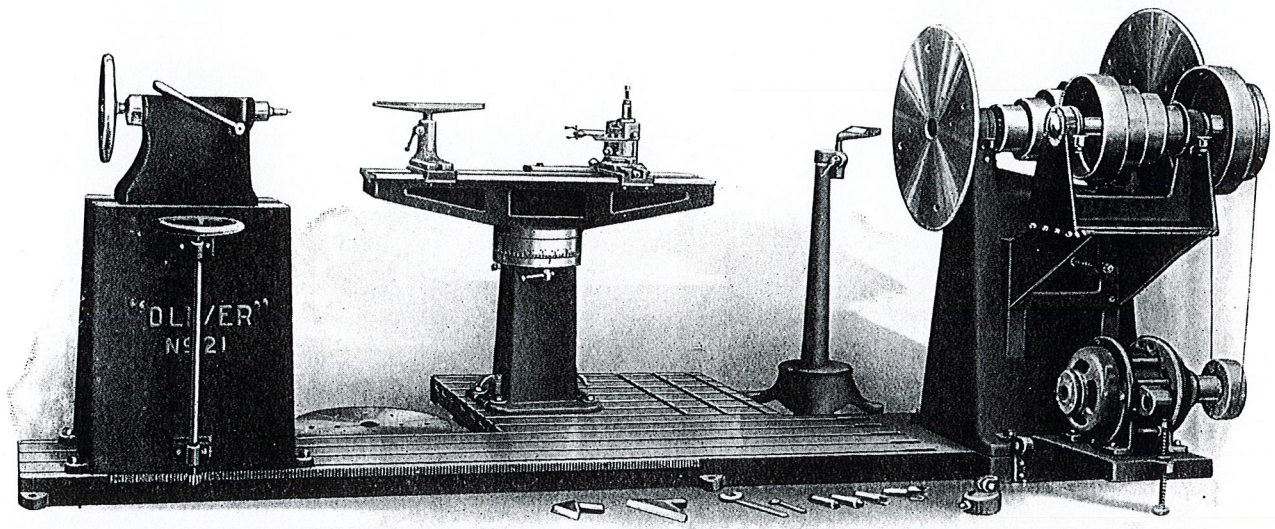

“OLIVER” NO. 21-AC PATTERN MAKERS’ COMBINATION LATHE
Rear View showing ease with which Tail Stock Column and Carriage Stand can be moved to any place desired. Note — Rest Holder shown on left end of Carriage is not regular equipment.

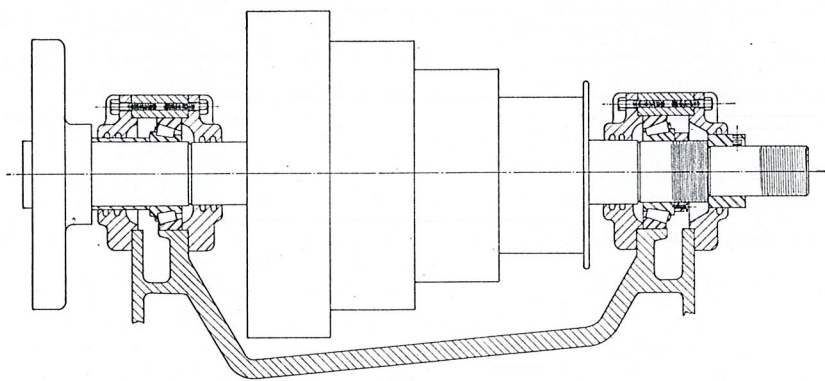

Cross Section through Head Stock Bearings showing extra heavy frictionless taper roller bearings with automatic lubrication.

This lathe is unique, not only in design, but in construction. In its manufacture we have adopted the lines pursued for machine tools, thus insuring a greater degree of satisfaction to the operators and a higher

quality of work. Heretofore pattern-makers have been at a loss to find a machine that combined the functions of ordinary turning with those of turning large diameters, long cylindrical patterns, gearing,

etc. Realizing these necessities, we have developed and perfected this machine, which, with its various modifications, has proven to be admirably adapted to meet these exacting demands.

Capacity

Will swing 92 inches diameter over the sole plate, 100 inches over the floor, and any desired diameter over a pit at the rear of the head stock. It will turn in length between centers, on a standard machine 6 feet 6 inches long, but it can be made to order any length advancing by sections of two feet. When using 5 h.p. Direct Current motor, minimum head stock speeds of 58, 94, 153 and 250 r.p.m. and maximum speeds of 232, 376, 612 and 1000 r.p.m. are obtained; when using Alternating Current two speed 5 h.p. motor, minimum head stock speeds of 77, 125, 204 and 333 r.p.m., and maximum speeds of 320, 532, 810 and 1400 r.p.m. are obtained.

Sole Plate

We build this any length. Upon it are mounted the various columns supporting the head and tail stock and the movable carriage. The casting is very heavy and in its surface "T" slots are planed, both lengthwise and crosswise, for the proper alignment of the tail stock and movable carriage column.

The 21-AC Sole Plate is 11 feet. 7 inches long, 35½ inches wide at headstock, 32½ inches wide in center and 24 inches wide at tailstock end. The 21-BC Sole Plate is 7 feet 10 inches long and 32½ inches wide. The carriage Sole Plate is 47 inches wide and 42¾ inches deep. All plates are 4 inches thick and have T-slots 6½ inches between centers.

Floor Space

The objection to most large lathes, particularly in the ordinary pattern shop, is that they take up a great deal of valuable space. The "OLIVER" with its movable parts bunched close to the head stock, and its sole plate embedded in the floor, is a point well worth considering.

Head Stock

This is mounted upon a very heavy column. Carries a stiff, strong, hollow spindle machine ground and supported in self-oiling bearings. The spindle has a 12-inch flange permanently shrunk on the rear end, which centers the large face plates which are bolted in place. Large, self-lubricated, taper roller bearings—opposed—eliminate longitudinal lost motion and properly carry both radial

and thrust loads in either direction. Cast iron cone pulley is machined both inside and out, and adjusted to a running balance.

Tail Stock

This is mounted on a column which may be adjusted to and from the head stock by means of a rack and pinion at its base, controlled by hand wheel. The top of this column, however, admits of a certain lateral motion of the tail stock. Sometimes it is necessary, in centering work, to move the tail stock instead of the center, and this adjustment is equal to a longer traverse of the tail spindle.

Movable Carriage and Tool Post

This idea is certainly new and admits performing an infinite variety of work. The alignment of the pillar is accomplished by loose keys which fit the various slots in the plate, and it may be adjusted to operate upon the largest diameters, or set directly underneath the center of the spindles to act as a bed for hand turning on small work, or set close to head and tail stock, parallel with them, in such a position as to admit of the centers coming together and still have a bed for convenient use upon extremely short work that requires two centers.

Carriage

This has hand feed by means of steel cut gear and rack. Cross slide has an exceptionally long traverse, as also has the swivel rest. Compound rest is accurately graduated and swivels to any angle. This swivel, in connection with the one shown between the carriage slide and the top of column, makes it possible to secure all the angles necessary in various bevel work. In the turning of large drums the end of the carriage slide may be inserted within the work being turned.

Hand Rest Socket

A socket carrying a rest for hand turning is provided and may be substituted instead of the compound swivel and tool post when desired.

Motor Drives

When direct current is available, a 5 h.p. variable speed motor with

range of 450 to 1800 r.p.m. is desirable. The motor is mounted on a hinged motor bracket, permitting maintenance of proper belt tension. Self-contained taper roller bearing countershaft is mounted on sliding frame acting on bracket in rear of head stock. Alignment is determined by machined seat. An adjusting screw operated from the front of the machine provides for correct belt tension and to relieve tension while shifting belt. When alternating current is employed the usual practice is to use a 5 h.p. two speed 600 and 1200 r.p.m. motor constant horsepower, and a two step belt drive between motor and self-contained countershaft.

Equipment

Two spur centers, 1 each 1¼-inch and 2-inch diameter. One cup center ¾-inch. Two conical centers 1¼-inch. Four face plates for spindle, 12-inch, 24-inch, 30-inch and 38-inch diameter. One rest holder arranged to attach to tool carriage. Three rests, 6 inches, 12 inches, and 18 inches long. One right angle rest 6 inches long. One portable floor stand with offset rest.

GENERAL DIMENSIONS

Head Stock

Height of spindle center, 46 inches from floor plate. Spindle bearings—Front, 2¾ inches; rear, 2⅞ inches diameter. Spindle, 36 inches long; 2⅞ inches diameter. Hole through spindle, ⅞-inch. Receives No. 4 Morse Taper. Cone on spindle—7 inches, 9½ inches, 12 inches and 14½ inches, 3½-inch face. Width of belt, 3¼ inches.

Carriage

Length of bed, 54 inches; height from base, 35¾ inches. Traverse of cross feed, 11 inches. Traverse of compound rest, 6 inches. Travel of carriage on bed, 44 inches.

Extension Plate for Tail Stock

Length, 54 inches; width, 23 inches (see opposite page). Height, 4 inches. T slots 6½ inches between centers. Length over all, as shown on opposite page, 11 feet 6 inches.

OLIVER MACHINERY COMPANY  GRAND RAPIDS, MICHIGAN, U.S.A.

“OLIVER” NO. 21 PATTERN MAKERS’ COMBINATION LATHE

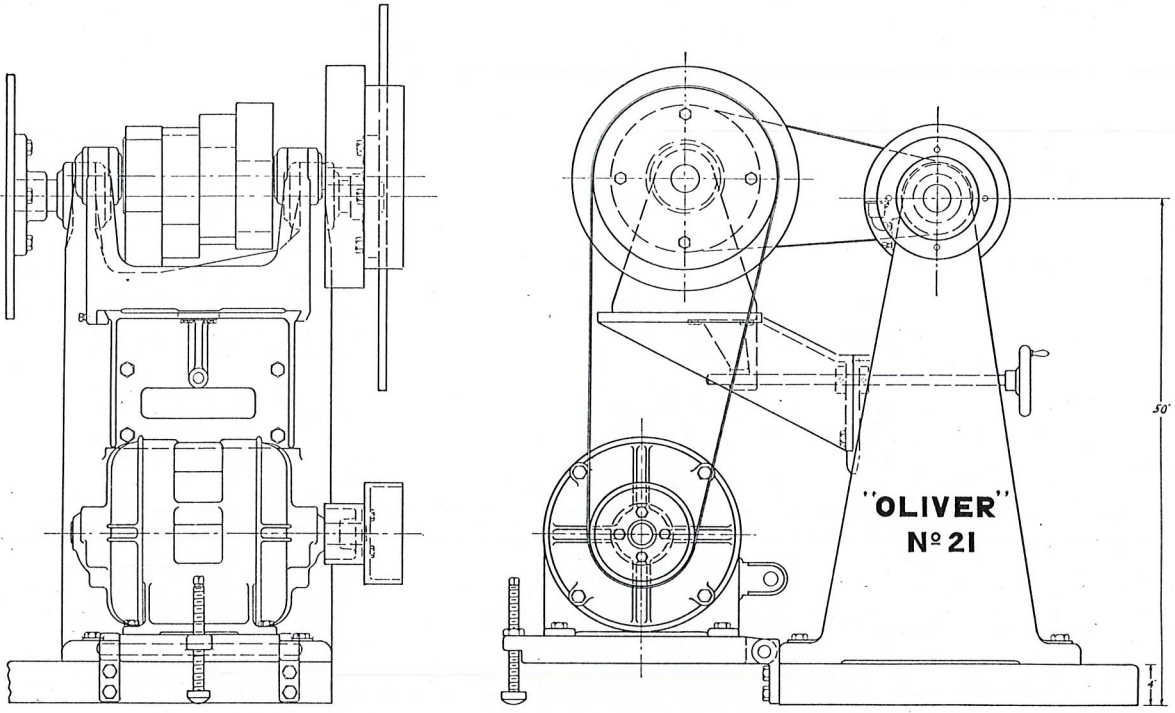

Motor Drive arrangement of No. 21 Combination Lathe.
Sheet Metal or Wire Mesh Guards for Belts and Pulleys furnished if desired.

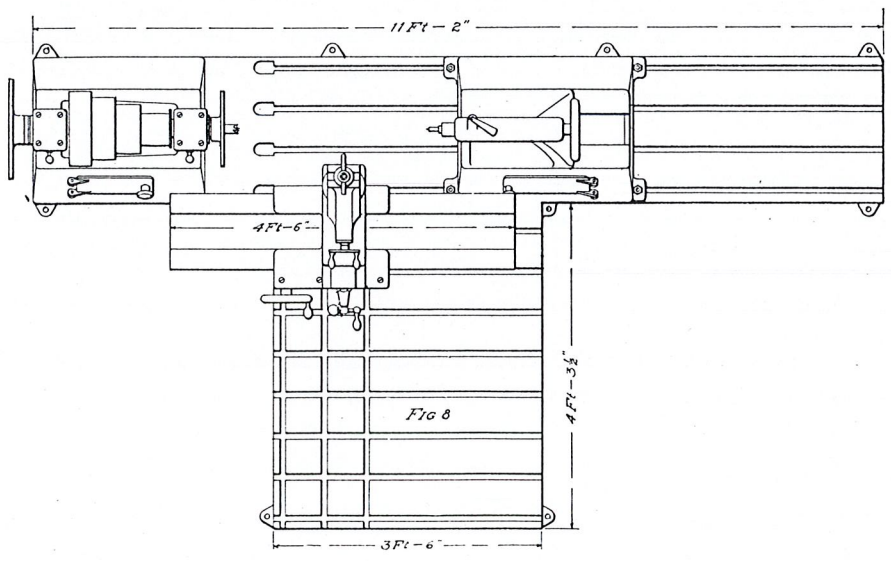

Etching showing Floor Plan of Machine with Tail Stock and Extension Sole Plate.

CODE, WEIGHT, ETC.

CODE	MACHINE DESCRIPTION	WEIGHT IN POUNDS		CUBIC FEET
		CRATED	BOXED	
Dowdy	No. 21-AC Lathe with Tail Stock and Sole Plate.....	7500	8600	220
Dower	No. 21-BC Lathe without Tail Stock, its portion of Sole Plate and Centers.....	5500	6550	175

